



Designation: E1129/E1129M – 15

Standard Specification for Thermocouple Connectors¹

This standard is issued under the fixed designation E1129/E1129M; the number immediately following the designation indicates the year of original adoption or, in the case of revision, the year of last revision. A number in parentheses indicates the year of last reapproval. A superscript epsilon (ϵ) indicates an editorial change since the last revision or reapproval.

1. Scope

1.1 This specification covers separable single-circuit thermocouple connectors with two round pins. Connectors covered by this specification must be rated for continuous use to at least 300°F (150°C), but they may optionally be rated to a higher temperature.

1.2 This specification does not cover multiple-circuit connectors, multi-pin connectors, miniature connectors, or connectors intended primarily for panel mounting. High temperature connectors (for example, those designed for continuous use at temperatures above approximately 500°F (260°C)) are not intended to be covered by this specification.

1.3 The values stated in either inch-pound units or SI units are to be regarded separately as standard.

1.4 The following precautionary statement pertains only to the test methods portion, Section 9, of this specification. *This standard does not purport to address all of the safety concerns, if any, associated with its use. It is the responsibility of the user of this standard to establish appropriate safety and health practices and determine the applicability of regulatory limitations prior to use.*

1.5 *This international standard was developed in accordance with internationally recognized principles on standardization established in the Decision on Principles for the Development of International Standards, Guides and Recommendations issued by the World Trade Organization Technical Barriers to Trade (TBT) Committee.*

2. Referenced Documents

2.1 The following documents of the latest issue form a part of this specification to the extent referenced herein. In case of conflict between this specification and another referenced document, this specification shall take precedence.

¹ This specification is under the jurisdiction of ASTM Committee E20 on Temperature Measurement and is the direct responsibility of Subcommittee E20.13 on Thermocouples - Materials and Accessories Specifications.

Current edition approved Dec. 1, 2015. Published January 2016. Originally approved in 1986. Last previous edition approved in 2014 as E1129 – 14. DOI: 10.1520/E1129_E1129M-15.

2.2 ASTM Standards:²

- E230/E230M Specification and Temperature-Electromotive Force (EMF) Tables for Standardized Thermocouples
- E344 Terminology Relating to Thermometry and Hydrometry
- E608/E608M Specification for Mineral-Insulated, Metal-Sheathed Base Metal Thermocouples
- E2820 Test Method for Evaluating Thermal EMF Properties of Base-Metal Thermocouple Connectors

3. Terminology

3.1 *Definitions*—The definitions given in Terminology E344 shall apply.

3.2 Definitions of Terms Specific to This Standard:

3.2.1 *connector pair, n*—an assembly consisting of a plug and a jack, each having both positive and negative contact inserts, that will connect two parts of an electrical circuit and provide a means of physically disconnecting the two parts without the use of a tool.

3.2.2 *contact insert, n*—metallic conductor assembly that, when installed in a connector body, provides a connection between two parts of an electrical circuit. Plug connectors will contain projecting prong contacts, while jack connectors will contain recessed sockets or receptacle contacts.

3.2.3 *service life, n*—period of time that a connector assembly can be put to use and retain all physical and thermoelectric properties.

3.2.4 *test difference, n*—thermoelectric emf value attributable to mated connectors observed by the test procedure of this specification.

4. Significance and Use

4.1 The widespread use of thermocouple connectors requires standardization of mating dimensions and performance characteristics.

4.2 This specification describes standardized thermocouple connector dimensions and capabilities and includes test procedures suitable for evaluating the performance of a particular

² For referenced ASTM standards, visit the ASTM website, www.astm.org, or contact ASTM Customer Service at service@astm.org. For *Annual Book of ASTM Standards* volume information, refer to the standard's Document Summary page on the ASTM website.

specimen or design. The tests described are not intended for routine inspection or rapid testing of large groups of connectors or for quality control purposes.

5. Classification

5.1 Plugs or Jacks:

5.1.1 Connectors shall be constructed as either plugs or jacks, and these two forms shall be designed to connect with each other.

5.1.2 Plug connectors shall have two external prong contacts of differing diameters to prevent improper mating. The negative prong shall be the larger, as shown in Table 1 and Fig. 1.

5.1.3 Jack connectors shall have two internal socket contacts sized and spaced to receive and accommodate the prong contacts of the mating plug. Jack connectors shall also include a means of producing and maintaining sufficient contact pressure to meet all of the other requirements of this specification.

5.2 ANSI/ASTM Type:

5.2.1 Connectors shall be produced in versions to match each of the standardized ANSI/ASTM thermocouple types as given in Table 2.

5.2.2 The insert materials of each plug and jack shall have thermoelectric properties conforming to the nominal characteristics of the corresponding thermocouple type given in Specification E230/E230M over the operating temperature range specified in Table 3.

5.2.3 Calibration conformance and gradient testing is not applicable to Type B thermoelectrically neutral (Cu/Cu) connectors.

6. Ordering Information

6.1 Orders for connectors under this specification shall include the following:

6.1.1 Quantity of plugs or jacks (specify which);

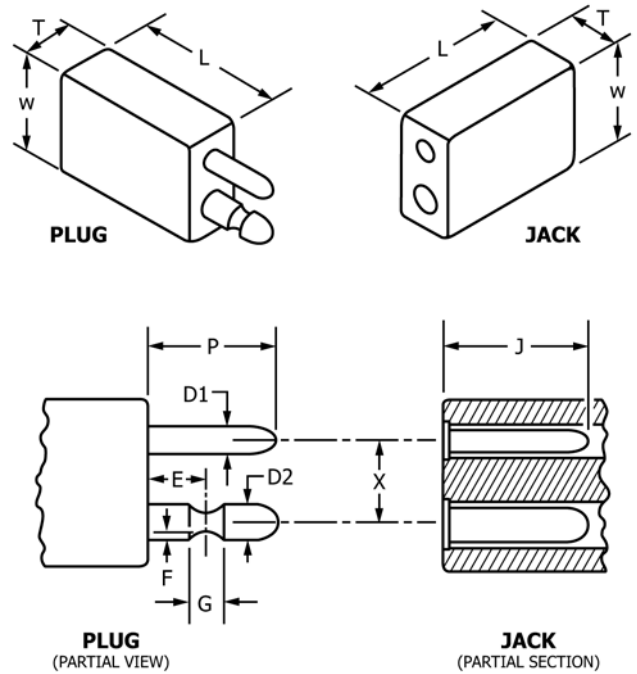

NOTE 1—A solid prong is shown for clarity of design.

FIG. 1 Thermocouple Connector Dimensions, (see Table 1)

TABLE 2 Identification

ANSI / ASTM Type	Body Color Coding
T	Blue
J	Black
E	Purple
K	Yellow
N	Orange
R or S	Green
B (Cu/Cu) ^A	White

^AUncompensated (Cu/CU) connectors are customarily used with Type B thermocouples.

TABLE 1 Dimensions

Dimension	Symbol ^A	Minimum, in. (mm)	Maximum, in. (mm)
Body length	L	...	1.505 (38.23)
Body width	W	...	1.088 (27.64)
Body thickness	T	...	0.515 (13.08)
Length of prong	P	0.535 (13.59)	0.650 (16.51)
Depth of socket	J	0.650 (16.51)	...
Prong spacing	X	0.432 (10.97)	0.442 (11.23)
Positive pin diameter	D1	0.152 (3.86)	0.158 (4.02)
Negative pin diameter	D2	0.182 (4.62)	0.190 (4.83)
Location of detent	E	0.180 (4.57)	0.200 (5.08)
Depth of detent	F	0.010 (0.25)	0.025 (0.64)
Width of detent	G	0.040 (1.02)	...

^A Symbols are according to Fig. 1.

- 6.1.2 ANSI/ASTM thermocouple type (see Table 2);
- 6.1.3 Any optional accessories that may be required, such as those listed in 7.4.3;
- 6.1.4 Special testing requirements; and
- 6.1.5 Requirements for certificates of conformance to the specifications or reports of the results of any required testing.

7. Materials and Manufacture

7.1 Body:

7.1.1 The dimensions of the connector bodies shall fall within the limits given in Table 1.

7.1.2 The connector body shall be made of an electrically insulating material capable of continuous use at any temperature between 0°F (-18°C) and 300°F (150°C) for the service life given in Table 3, without losing its ability to conform to this specification.

7.1.3 The connector bodies shall be color coded in accordance with Table 2 to provide rapid and permanent identification of the thermocouple calibration with which it is designed to be used. Each plug and jack shall be permanently marked with a symbol or symbols to identify positive and negative