



Designation: **F1458–04 (Reapproved 2008) F1458 – 15**

Standard Test Method for Measurement of Cut Resistance to ~~Chain Saw~~ Chainsaw of Foot Protective Devices¹

This standard is issued under the fixed designation F1458; the number immediately following the designation indicates the year of original adoption or, in the case of revision, the year of last revision. A number in parentheses indicates the year of last reapproval. A superscript epsilon (ϵ) indicates an editorial change since the last revision or reapproval.

1. Scope

1.1 This test method measures cut resistance of foot protective devices that are designed to protect the foot when operating a ~~chain saw~~, chainsaw.

1.2 This test method may be used to test for compliance to minimum performance requirements in established safety standards.

1.2.1 By agreement between the purchaser and the supplier, or as required by established safety standards, this test method can be used to determine any one or both of the following: (1) ~~chainspeed~~ chain speed 50 (CS50), (2) success/failure (jamming/chain stop) at specified chain speed.

1.3 This test method may be used to determine levels of protection for areas of coverage as stipulated in established safety standards.

1.4 The values stated in SI units are to be regarded as standard.

NOTE 1—The values stated in each system may not be exact equivalents; therefore, each system must be used independently of the other, without combining values in any way.

1.5 *This standard does not purport to address all of the safety concerns, if any, associated with its use. It is the responsibility of the user of this standard to establish appropriate safety and health practices and determine the applicability of regulatory limitations prior to use.*

2. Referenced Documents

2.1 *ASTM Standards:*²

D123 Terminology Relating to Textiles

D1056 Specification for Flexible Cellular Materials—Sponge or Expanded Rubber

D1776 Practice for Conditioning and Testing Textiles

F1414 Test Method for Measurement of Cut Resistance to Chainsaw in Lower Body (Legs) Protective Clothing

F1494 Terminology Relating to Protective Clothing

2.2 *AATCC Test Methods:*³

AATCC 96 Dimensional Changes in Laundering of Woven and Knitted Fabrics, Except Wool (1988)

AATCC 158 Dimensional Changes on Drycleaning in Perchloroethylene: Machine Method

2.3 *Military Standards:*⁴

MIL-STD-105 Sampling Procedure and Tables for Inspection by Attributes

MIL-C-12369 Cloth, Ballistic, Nylon

2.4 *Federal Standard:*⁵

FS 5100-86 Type II, Cloth, Duck, Nylon, Polyurethane Coated

¹ This test method is under the jurisdiction of ASTM Committee F23 on Personal Protective Clothing and Equipment and is the direct responsibility of Subcommittee F23.20 on Physical.

Current edition approved June 15, 2008; Nov. 1, 2015. Published July 2008; January 2016. Originally approved in 1998. Last previous edition approved in 2004 as F1458–04; F1458–04(2008). DOI: 10.1520/F1458-04R08; 10.1520/F1458-15.

² For referenced ASTM standards, visit the ASTM website, www.astm.org, or contact ASTM Customer Service at service@astm.org. For *Annual Book of ASTM Standards* volume information, refer to the standard's Document Summary page on the ASTM website.

³ Available from American Association of Textile Chemists and Colorists (AATCC), P.O. Box 12215, Research Triangle Park, NC 27709-2715, http://www.aatcc.org.

⁴ Available from Standardization Documents Order Desk, DODSSP, Bldg. 4, Section D, DLA Document Services, Building 4/D, 700 Robbins Ave., Philadelphia, PA 19111-5098, http://www.dodssp.daps.mil/19111-5094, http://quicksearch.dla.mil.

⁵ Available from Superintendent of Documents, U.S. Government Printing Office, Washington, DC 20402; Publishing Office, 732 North Capitol Street, NW, Washington, DC 20401-0001, http://www.gpo.gov.

3. Terminology

3.1 Definitions:

3.1.1 *centerline, n*—*in foot protective devices*, a line that extends from the toe of the footwear horizontally along the sole to the heel vertically to the top of the footwear, and diagonally to the point of intersection at the toe.

3.1.2 ~~chain saw~~, *chainsaw, n*—a portable power-operated tool that has cutters linked in a chain used for cutting wood.

3.1.3 *chain speed, n*—the ~~velocity~~speed of synchronized movement of linked cutters around a bar and sprocket.

3.1.4 ~~chainspeed~~ *chain speed 50 (CS50), n*—for ~~chain saw~~ chainsaw protection, the mean ~~velocity~~speed at which cut through occurs.

3.1.4.1 Discussion—

This value establishes the relationship between the probability of cutting through the ~~chain saw~~ chainsaw leg protective clothing (or foot protective device) and the speed of the saw chain. For lower chain speeds, the probability of cut through approaches zero, while for higher chain speeds, the probability of cut through approaches one.

3.1.5 *chain stop, n*—for ~~chain saw~~ chainsaw cut resistance, the resulting action when a material clogs (jams) the drive sprocket or slows the speed sufficiently to prevent advancement of the saw chain.

3.1.6 *cut resistance, n*—the ability of a material, while in contact with the linked cutters, to resist cut through of the cutters of a moving saw chain, independent of either jamming or chain stop.

3.1.7 *foot, n*—the terminal part of the vertebrate leg, including the ankle, upon which an individual stands.

3.1.8 *foot protective device, n*—for ~~chain saw~~ chainsaw cut resistance, an article of personal equipment which covers the foot and ankle for the purpose of providing limited protection from injury due to contact with a moving saw chain.

3.1.9 *footwear, n*—a boot or shoe of any construction.

3.1.10 *gaiter, n*—for ~~chain saw~~ chainsaw cut resistance, a foot protective device permanently attached to the outside of the footwear.

3.1.11 *jamming, n*—for ~~chain saw~~ chainsaw cut resistance, the clogging action manifested by a protective garment or device that can produce a chain stop.

3.1.12 *saw chain, n*—a closed loop of cutters linked together for use in a portable power-operated tool.

3.1.13 *toe area cut zone, n*—*in the testing of foot protective devices*, that area excluding the sole that extends from the frontmost part of the footwear to a vertical plane 15 ± 0.25 mm behind the toe box; or in the absence of a toe box, the area that extends to a vertical plane 65 ± 6.25 mm from the front of the footwear.

3.1.14 *toe box, n*—*in testing of foot protective devices*, a component inserted into the toe area of footwear.

3.1.15 *upper, n*—that area of the footwear above the sole.

3.1.16 *upper cut zone, n*—*in the testing of foot protective devices*, the area starting at the top of the area of protection on the footwear and extending downward to include the entire upper, but excluding the toe area cut zone.

3.2 For definitions of other protective clothing terms used in this test method, refer to Terminology F1494.

4. Summary of Test Method

4.1 Test specimens are securely mounted on a test apparatus.

4.2 A chain saw, of specific characteristic and operating at a designated speed, is brought into contact with the test specimen at specified locations.

4.2.1 The cutting action of the saw chain will achieve one of three results (1) complete cut through, (2) no cut through while saw chain continues to run, or (3) complete chain stop.

4.3 Data collection of cut resistance and CS50 is measured electronically by means of wires placed on the top and the bottom of the test specimen to measure cut through time, and an electronic means to measure chain speed just prior to contact with test specimen and after contact is initiated.

5. Significance and Use

5.1 The purpose of this test method is to provide a measurable criterion of performance defining the level of cut resistance to the cutting action of a saw chain provided by foot protective devices.

5.2 The protection, which can be demonstrated by the foot protective devices, tested in accordance with this test method, is achieved by (1) the material resisting cutting when put in contact with the moving saw chain; (2) a part of the material being drawn

into the saw chain and drive mechanism to block the saw chain movement; (3) the materials resisting cutting and absorbing rotational energy so that saw chain speed can be slowed down sufficiently to stop the movement of the saw chain; or (4) any combination of these.

5.3 In case of a dispute arising from differences in reported test results, when using this test method for acceptance testing of commercial shipments, the purchaser and the supplier should perform comparative tests to determine if there is a statistical bias between their laboratories. Competent statistical assistance is recommended for the investigation of bias. As a minimum, the two parties should take a group of test specimens from the same lot of components to be evaluated. The test specimens should then be randomly assigned in equal numbers to each laboratory for testing. If a bias is found, either its cause must be determined and corrected, or the purchaser and the supplier must agree to interpret future test results in light of the known bias.

6. Apparatus

6.1 *Specimen Holder for Calibration*, in accordance with Test Method F1414.

6.2 *Mounting Bracket for Footwear and Footwear with Protective Devices*:

6.2.1 The mounting bracket must enable the footwear to be moved so that test cuts can be made at stipulated positions (see Fig. 1-4 to 4).

6.2.2 The mounting bracket shall enable footwear to be secured for testing in a manner that neither enhances nor inhibits the cut resistance of the foot protective device.

NOTE 2—Securing or mounting mechanisms should enable footwear, if necessary, to be used for multiple evaluations of protective devices.

6.3 *Footwear Form for Mounting Removable Foot Protective Device*:^{6,7}

6.3.1 The footwear form used for mounting a removable foot protective device shall be similar to that shown in Fig. 5.

6.3.2 The method of securing the foot protective device to the form shall be the same as that method used to secure the device to footwear.

6.3.3 The form shall then be secured for testing to the aforementioned mounting bracket in a manner that neither enhances nor inhibits the cut resistance of the foot protective device.

6.4 ~~Chain Saw~~ *Chainsaw and Related Equipment*—The ~~chain saw~~ chainsaw and related equipment is in accordance with Test Method F1414.

6.5 ~~Chain Saw~~ *Chainsaw Support Bracket*—The ~~chain saw~~ chainsaw support bracket is in accordance with Test Method F1414.

6.6 *Interfaced Data Acquisition System*—The interfaced data acquisition system is in accordance with Test Method F1414.

6.7 *Filling Material*:^{8,7}

6.7.1 The filling material used to provide shape and mass to the footwear shall be pellets made of a high-density polyethylene similar to that used for injection molding.

6.7.1.1 This includes footwear with ~~chain saw~~ chainsaw cut protection which is an integral part of the footwear, as well as the footwear that is worn on the inside of a removable foot protective device.

6.7.2 The filling material shall be held in place by covering with a weight of 2 kg ± 20 g.

⁶ The sole source of supply of the footwear form known to the committee at this time is Satra, Satra House, Rockingham Road, Kettering, Northants, NN16 9JH, England.

⁷ If you are aware of alternative suppliers, please provide this information to ASTM International Headquarters. Your comments will receive careful consideration at a meeting of the responsible technical committee, which you may attend.

⁸ The sole source of supply of the Style No. LM-6007-00 polyethylene pellets known to the committee at this time is Quantum Chemical Corp., 11500 N. Lake Drive, Cincinnati, OH 45249.

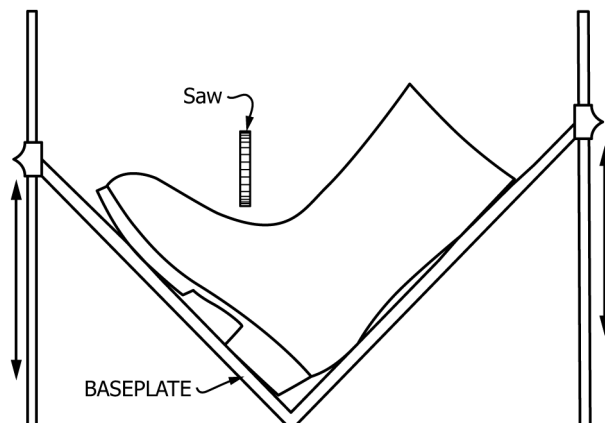

FIG. 1 Upper Cut Test Position

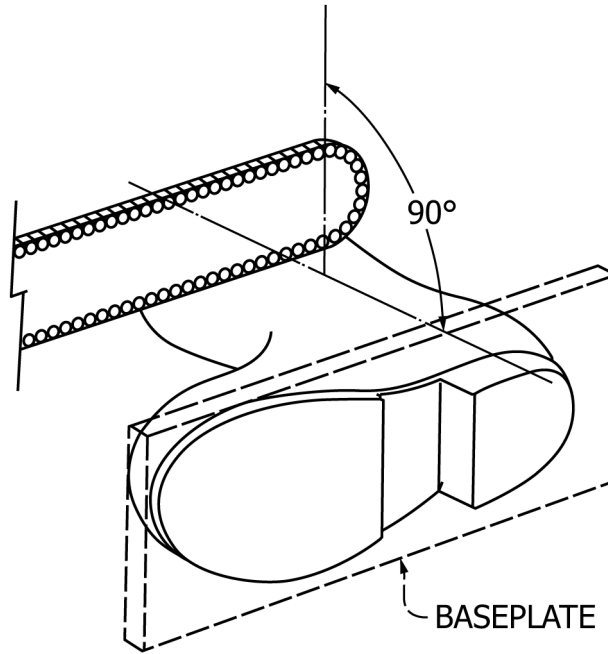

FIG. 2 Upper Test Cut Position

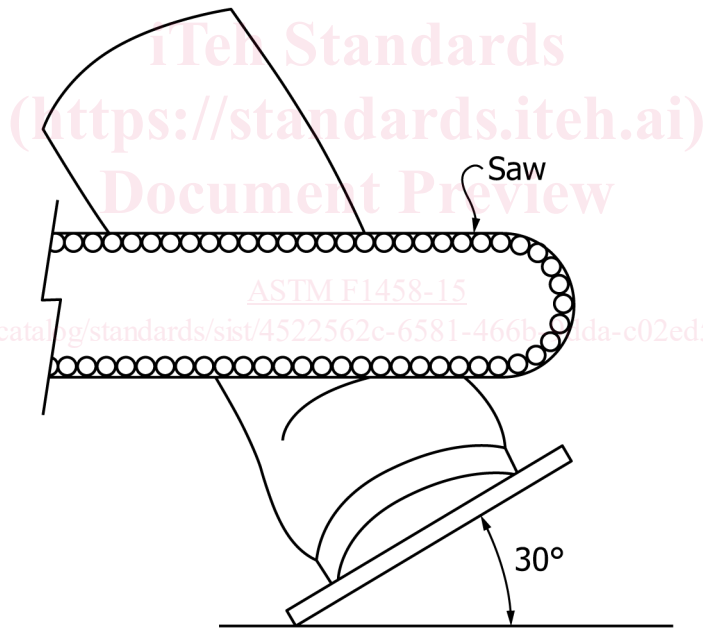

FIG. 3 Toe Cut Test Position

NOTE 3—The weight can be a bag containing leadshot, sand, steel pellets, or some other material to achieve the desired mass.

7. Hazards

NOTE 4—**Warning:** The ~~chain saw~~ chainsaw equipment used in the procedure of this test method can pose a potential danger to the technician if specific safety precautions are not followed.

7.1 As a minimum safety precaution, it is suggested that the spark plug wire be disengaged until the engine needs to be started.

7.2 As a further safety precaution, it is suggested that the spark plug wire be grounded by circuitry after cutting the lower wire of the data collection system. If the saw chain stops before the wire is cut, or if the saw chain slides over the specimen, a timer should limit the test and stop the engine by grounding the electric circuitry of the ~~chain saw~~ chainsaw.

7.3 The technician performing these tests should use hearing protection to avoid potential loss of hearing.

7.4 The technician performing these tests should use eye protection to avoid potential eye injury.

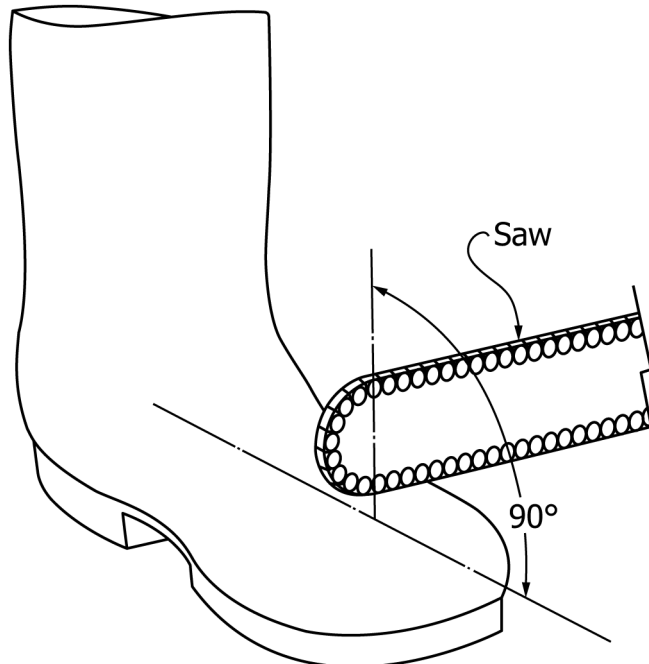

FIG. 4 Toe Cut Test Position

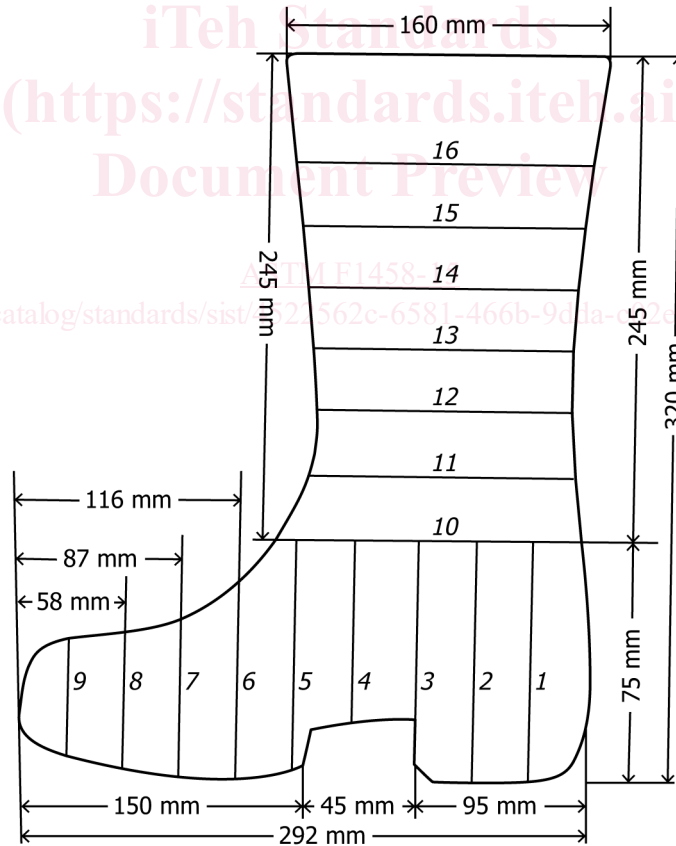

FIG. 5 Footwear Form for Gaiter/Liner

7.5 The chain saw chainsaw engine should be vented to prevent potential danger posed by carbon monoxide.

8. Sampling

8.1 *Lot Sample*—The number of units that constitute a production lot and the number of samples required to be evaluated from that lot will be determined by agreement between the client and the facility using this test method. This determination must also consider how many units constitute a meaningful measurement of consistent quality that will result in achievement of similar values.

8.2 *Number of Specimens:*

8.2.1 A pair is considered as two test specimens, one left-foot protective device and one right-foot protective device.

8.2.2 If this test method is used to determine CS50 a minimum of six specimens (3 pairs) at each test cut position will be needed.

8.2.3 If this test method is used to determine “pass/fail” at a specific saw chain speed of an established safety standard, a minimum of six specimens (3 pairs) at each test cut position must pass.

8.2.4 If this test method is used to determine cut through time at a specified speed, a minimum of six specimens (3 pairs) at each test cut position will be needed.

9. Calibration

9.1 The calibration procedures described in Test Method **F1414** shall be utilized for this test method.

10. Conditioning

10.1 *Footwear:*

10.1.1 Place the footwear in a room with an ambient condition of $70 \pm 10^\circ\text{F}$ ($21 \pm 6^\circ\text{C}$) and a relative humidity of $50 \pm 15\%$.

10.1.2 Footwear shall be conditioned in this manner for at least 24 h.

10.2 *Foot Protective Devices Permanently Attached:*

10.2.1 *Textile Materials*—Condition textile foot protective devices that are permanently attached to the footwear in the same manner as footwear.

10.2.2 *Non-Textile Materials*—Condition non-textile foot protective devices that are permanently attached to the footwear in the same manner as footwear.

10.3 *Foot Protective Devices Not Permanently Attached:*

10.3.1 *Textile Materials*—Condition textile foot protective devices that are not permanently attached to the footwear in the same manner as footwear.

10.3.2 *Non-Textile Materials*—Condition non-textile foot protective devices that are not permanently attached to the footwear in the same manner as footwear.

11. Procedure

11.1 *Preparation and Mounting of Specimen:*

11.1.1 *Footwear with Integral ~~Chain Saw~~ Chainsaw Protection or Gaiter:*

11.1.1.1 To test the toe area cut zone of footwear with integral ~~chain saw~~ chainsaw protection or gaiter, fill the footwear with filling material to a level above the ankle area of the footwear. The weight in accordance with Section 6 shall be used to secure this material in place.

11.1.1.2 To test the upper cut zone of footwear, with integral ~~chain saw~~ chainsaw protection or gaiter, at all angles between 0 to 90° , fill the footwear with a material that provides shape and mass; or depending upon the angle of cut, mount the footwear onto a tapered form in accordance with **Fig. 6** and **Fig. 7**.

11.1.1.3 Secure the footwear to the mounting bracket of the test apparatus.

11.1.1.4 Position the bottom timing wire from the interfaced data acquisition system perpendicular to the horizontal axis of the guide bar at the point of contact and snug to the inside of the footwear. Position the top wire of the interfaced data acquisition system perpendicular to the horizontal axis of the guide bar at the point of contact and snug to the outside of the footwear.

11.1.1.5 For footwear with a gaiter, position the bottom timing wire from the interfaced data acquisition system perpendicular to the horizontal axis of the guide bar at the point of contact and secure it to be snug to the bottom side of the gaiter. Position the top wire of the interfaced data acquisition system perpendicular to the horizontal axis of the guide bar at the point of contact and snug to the outside of the footwear.

11.1.2 *Removable Foot Protective Device:*

11.1.2.1 To test the toe area cut zone of removable foot protective device, fill the footwear with filling material to a level above the ankle area of the footwear. The filling material will be secured in place as described in Section 6.

11.1.2.2 To test the upper cut zone of removable foot protective devices, at all angles between 0° to 90° , fill the footwear with a material that provides shape and mass; or depending upon the angle of cut, use a tapered form as described in **Fig. 6** and **Fig. 7**.

11.1.2.3 Secure the removable foot protective device with the footwear to the mounting bracket of the test apparatus.

11.1.2.4 For removable foot protective device, position the bottom timing wire from the interfaced data acquisition system perpendicular to the horizontal axis of the guide bar at the point of contact and secure it to be snug to the bottom side of the foot