



Designation: D4648/D4648M – 16

Standard Test Methods for Laboratory Miniature Vane Shear Test for Saturated Fine-Grained Clayey Soil¹

This standard is issued under the fixed designation D4648/D4648M; the number immediately following the designation indicates the year of original adoption or, in the case of revision, the year of last revision. A number in parentheses indicates the year of last reappraisal. A superscript epsilon (ϵ) indicates an editorial change since the last revision or reappraisal.

1. Scope*

1.1 These test methods cover the miniature vane test in very soft to stiff saturated fine-grained clayey soils ($\phi = 0$). Knowledge of the nature of the soil in which each vane test is to be made is necessary for assessment of the applicability and interpretation of the test results.

NOTE 1—It is recommended that the miniature vane test be conducted in fine-grained, predominately clay soils with an undrained shear strength less than 1.0 tsf [100 kPa]. Vane failure conditions in higher strength clay and predominantly silty soils may deviate from the assumed cylindrical failure surface, thereby causing error in the measured strength.

1.2 These test methods include the use of both conventional calibrated torque spring units (Method A) and electrical torque transducer units (Method B) with a motorized miniature vane shear device.

1.3 Laboratory vane is an ideal tool to investigate strength anisotropy in the vertical and horizontal directions, if suitable samples (specimens) are available.

1.4 All measured and calculated values shall conform to the guidelines for significant digits and rounding established in Practice D6026.

1.5 The values stated in either SI units or inch-pound units are to be regarded separately as standard. The values stated in each system may not be exact equivalents; therefore, each system shall be used independently of the other. Combining values from the two systems may result in non-conformance with the standard.

1.5.1 The gravitational system of inch-pound units is used when dealing with inch-pound units. In this system, the pound (lbf) represents a unit of force (weight), while the unit for mass is slugs. The rationalized slug unit is not given, unless dynamic ($F = ma$) calculations are involved.

1.6 *This standard does not purport to address all of the safety concerns, if any, associated with its use. It is the responsibility of the user of this standard to establish appropriate*

appropriate safety and health practices and determine the applicability of regulatory limitations prior to use.

2. Referenced Documents

2.1 ASTM Standards:²

D653 Terminology Relating to Soil, Rock, and Contained Fluids

D1587 Practice for Thin-Walled Tube Sampling of Fine-Grained Soils for Geotechnical Purposes

D2216 Test Methods for Laboratory Determination of Water (Moisture) Content of Soil and Rock by Mass

D2488 Practice for Description and Identification of Soils (Visual-Manual Procedure)

D2573 Test Method for Field Vane Shear Test in Saturated Fine-Grained Soils

D3740 Practice for Minimum Requirements for Agencies Engaged in Testing and/or Inspection of Soil and Rock as Used in Engineering Design and Construction

D4220 Practices for Preserving and Transporting Soil Samples

D6026 Practice for Using Significant Digits in Geotechnical Data

3. Terminology

3.1 Definitions:

3.1.1 For common definitions of terms in this standard, refer to Terminology D653.

3.2 Definitions of Terms Specific to This Standard:

3.2.1 *torque*—the product of the magnitude of a force and the perpendicular distance of the line of action of the force from a specified axis of rotation.

3.2.2 *torque spring*—an elastic spring that can be calibrated to provide a measure of torque that is proportional to the rotation (about a central longitudinal axis) of one end of the spring relative to a fixed condition at the opposite end of the spring.

¹ This test method is under the jurisdiction of ASTM Committee D18 on Soil and Rock and is the direct responsibility of Subcommittee D18.05 on Strength and Compressibility of Soils.

Current edition approved Jan. 1, 2016. Published January 2016. Originally approved in 1987. Last previous edition approved in 2013 as D4648/D4648M – 13. DOI: 10.1520/D4648_D4648M-16.

² For referenced ASTM standards, visit the ASTM website, www.astm.org, or contact ASTM Customer Service at service@astm.org. For *Annual Book of ASTM Standards* volume information, refer to the standard's Document Summary page on the ASTM website.

*A Summary of Changes section appears at the end of this standard

3.2.3 *torque transducer*—an electronic measuring device that can be calibrated to provide a measure of torque.

4. Summary of Test Method

4.1 The miniature vane shear test consists of inserting a four-bladed vane in the end of an intact tube sample or remolded sample and rotating it at a constant rate to determine the torque required to cause a cylindrical surface to be sheared by the vane. This torque is then converted to a unit shearing resistance of the cylindrical surface area. The torque is measured by a calibrated torque spring or torque transducer that is attached directly to the vane.

5. Significance and Use

5.1 The miniature vane shear test may be used to obtain estimates of the undrained shear strength of fine-grained soils. The test provides a rapid determination of the shear strength on undisturbed, or remolded or reconstituted soils.

NOTE 2—Notwithstanding the statements on precision and bias contained in this test method: The precision of this test method is dependent on the competence of the personnel performing it and the suitability of the equipment and facilities used. Agencies that meet the criteria of Practice D3740 are generally considered capable of competent and objective testing. Users of this test method are cautioned that compliance with Practice D3740 does not in itself ensure reliable testing. Reliable testing depends on several factors; Practice D3740 provides a means for evaluating some of those factors.

6. Interferences

6.1 *Vane Disturbance*—The remolded zone around a vane blade resulting from insertion is generally assumed to be small and have little or no effect on the stress-strain properties of the sediment being tested. In reality, the volume of soil disturbed by the insertion of the vane blade into the assumed cylindrical volume of soil being tested may be significant. It is recom-

mended that the vane displace no more than 15% of the soil being tested as defined by the vane area ratio presented in Fig. 1.

7. Apparatus

7.1 *Vane Blade*—The vane assembly shall consist of four rectangular bladed vanes, as illustrated in Fig. 2. It is recommended that the height of the vane be twice the diameter (2:1), although vanes with a height equal to the diameter (1:1) also may be used (see Note 3). Vane blade diameter (*D*) may vary from 0.5 to 1.0 in. [12.7 to 25.4 mm].

7.2 *Vane Device*—The vane device should be motorized and, in the case of a torque spring device, shall rotate the torque spring at a constant rate of 60 to 90°/min [1.0 to 1.6 rad/min]. A vane device which applies the torque directly through a stiff shaft using an electrical transducer to measure torque shall rotate the vane at a constant rate that ranges from 20 to 30°/min [0.35 to 0.52 rad/min]. The vane/spring rotation device shall have an indicator or recording system that displays/records deflection (torque) of the calibrated spring or electrical transducer and, where possible, vane blade rotation.

7.3 *Torque Measuring Device*—The torque measuring device shall be a conventional torque spring, electrical torque transducer, or any other measuring device capable of the accuracy prescribed herein and may be part of the vane device. The torque measuring device shall be capable of measuring the torque to at least three significant digits.

NOTE 3—Since many clays are anisotropic with respect to strength, the relative importance of horizontal, as distinct from vertical, shearing surfaces can influence the test results. For this reason it is important that the recommended ratio of height to diameter be respected unless the intent is to vary the ratio in order to determine the horizontal and vertical strengths separately. For more detailed discussion on effects of height to

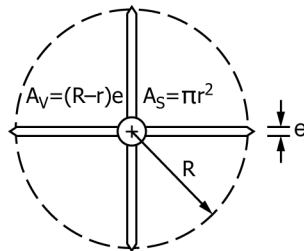

$$V_A = \frac{4(R-r)e + \pi r^2}{\pi R^2}$$

Where : V_A = Vane Area Ratio
 R = Radius of Failure Cylinder (in or mm)
 r = Radius of Vane Shaft (in or mm)
 e = Vane Blade Thickness (in or mm)

VANE TYPE	BLADE DIA. in (mm)	SHAFT DIA. in (mm)	BLADE THICKNESS in (mm)	AREA RATIO (%)
Miniature	0.50 (12.7)	0.1275 (3.5)	0.019 (0.05)	13.7

FIG. 1 Vane Area Ratio for ASTM Vanes

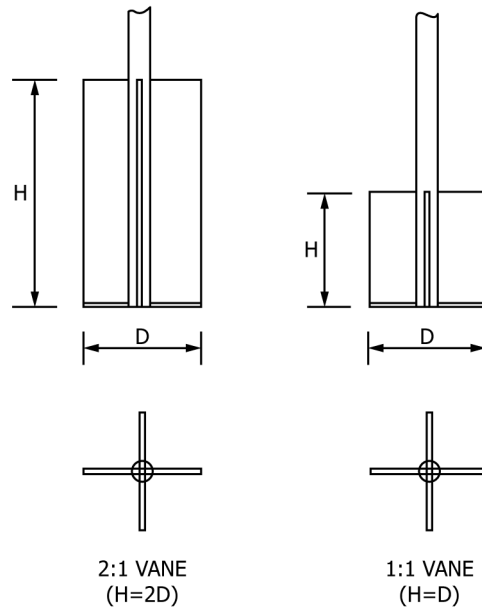

FIG. 2 Miniature Vane Blade Geometry

diameter ratio as well as vane shape, refer to Refs. (1) and (2).³

8. Preparation and Testing of Samples

8.1 *Specimen Size*—Specimens should have a diameter sufficient to allow clearance of at least two blade diameters between all points on the circumference of the shearing surface and the outer edge of the sample.

8.2 *Intact Vane Strength*—Prepare intact specimens from large intact samples secured in accordance with Practice D1587, and handle and transport in accordance with the practices for Group C and D Samples in Practices D4220. Tests may be run in the sampling tube, eliminating the need for extrusion. Handle specimens carefully to prevent disturbance or loss of water (moisture) content. Trim flat the end of the sample where the vane will be inserted. The sample shall be perpendicular to the wall of the tube.

8.3 *Remolded Vane Strength*—Conduct remolded miniature vane strength tests on failed specimens similar to remolded field vane tests (Test Method D2573) by rotating the vane rapidly through a minimum of five to ten revolutions.

NOTE 4—Remolded shear strength measurements are conventionally obtained by conducting strength tests on specimens encased in a thin rubber membrane, to prevent change in water content, and remolded by hand (hand remolding). Field vane remolded strength has however been obtained by rotating the vane rapidly through a minimum of five to ten complete revolutions and conducting a vane test within 1 min of the remolding process (machine remolding). A machine remolded test yields a vane strength value that is considered more a residual strength. The machine remolded strength is typically higher than the hand remolded strength and, as a consequence, produces lower sensitivities. In many sensitive clayey soils, residual strengths may be obtained within one to two revolutions or less. If such soils are being tested, it is recommended that several remolded strengths be obtained using the standard five to ten revolutions for verification. If no major remolded strength differences are

noted, remolded strengths may be obtained at less than the recommended five to ten revolutions.

NOTE 5—In cases where electrical torque transducers with wires for signal transmission are utilized, the remolded miniature vane strength may be obtained by rotating the vane one complete revolution in one direction and then again in the opposite direction a number of times to produce the desired five to ten complete revolutions.

9. Preparation of Apparatus

9.1 *Vane Blade Damage*—Carefully check each vane prior to each use for bent shafts and blades and imperfections that could alter the vane failure surface from the assumed cylindrical surface.

10. Calibration

10.1 Conduct periodically calibration of the spring units (or torque transducers) to ensure proper operation of the miniature vane device and repeatability of the torque spring or transducers. Calibration is accomplished by the application of calibrated weights onto a calibrated wheel to produce a known torque (lever arm X weight). Secure the vane shear unit in such a way that the vane spring (torque unit) is in a horizontal position. Then insert the calibration wheel in place of the vane blade. The calibration wheel, calibration string, and calibration weights all shall hang free of any obstructions. Dimensions of the calibration wheel shall be noted; specifically the lever arm.

10.2 For each vane torque spring to be used, apply a series of calibration weights to the calibration wheel to develop a plot of spring deflection (in degrees) versus torque (in lbf-in. or [N·m]). Carefully fasten each calibration weight to the calibration string and allow to deflect the spring. Record the deflection of the spring (in degrees) and applied torque for each weight applied. The calibration wheel configuration, lever arm, weights, and resulting torque shown in Fig. 3 is recommended for consideration in the calibration procedure.

³ The boldface numbers in parentheses refer to the list of references at the end of this standard.