



Designation: C78/C78M – 15b

Standard Test Method for Flexural Strength of Concrete (Using Simple Beam with Third-Point Loading)¹

This standard is issued under the fixed designation C78/C78M; the number immediately following the designation indicates the year of original adoption or, in the case of revision, the year of last revision. A number in parentheses indicates the year of last reapproval. A superscript epsilon (ϵ) indicates an editorial change since the last revision or reapproval.

This standard has been approved for use by agencies of the U.S. Department of Defense.

1. Scope*

1.1 This test method covers the determination of the flexural strength of concrete by the use of a simple beam with third-point loading.

1.2 The values stated in either SI units or inch-pound units are to be regarded separately as standard. The values stated in each system may not be exact equivalents; therefore, each system shall be used independently of the other. Combining values from the two systems may result in non-conformance with the standard.

1.3 *This standard does not purport to address all of the safety concerns, if any, associated with its use. It is the responsibility of the user of this standard to establish appropriate safety and health practices and determine the applicability of regulatory limitations prior to use.*

2. Referenced Documents

2.1 *ASTM Standards:*²

[C31/C31M Practice for Making and Curing Concrete Test Specimens in the Field](#)

[C42/C42M Test Method for Obtaining and Testing Drilled Cores and Sawed Beams of Concrete](#)

[C192/C192M Practice for Making and Curing Concrete Test Specimens in the Laboratory](#)

[C617 Practice for Capping Cylindrical Concrete Specimens](#)

[C1077 Practice for Agencies Testing Concrete and Concrete Aggregates for Use in Construction and Criteria for Testing Agency Evaluation](#)

[E4 Practices for Force Verification of Testing Machines](#)

¹ This test method is under the jurisdiction of ASTM Committee C09 on Concrete and Concrete Aggregates and is the direct responsibility of Subcommittee C09.61 on Testing for Strength.

Current edition approved Dec. 1, 2015. Published January 2016. Originally approved in 1930. Last previous edition approved in 2015 as C78/C78M – 15a. DOI: 10.1520/C0078_C0078M-15B.

² For referenced ASTM standards, visit the ASTM website, www.astm.org, or contact ASTM Customer Service at service@astm.org. For *Annual Book of ASTM Standards* volume information, refer to the standard's Document Summary page on the ASTM website.

3. Significance and Use

3.1 This test method is used to determine the flexural strength of specimens prepared and cured in accordance with Test Methods C42/C42M or Practices C31/C31M or C192/C192M. Results are calculated and reported as the modulus of rupture. For the same specimen size, the strength determined will vary if there are differences in specimen preparation, curing procedure, moisture condition at time of testing, and whether the beam was molded or sawed to size.

3.2 The measured modulus of rupture generally increases as the specimen size decreases^{3,4,5} and it has been shown that the variability of individual test results increases as the specimen size decreases.^{3,4}

3.3 The results of this test method may be used to determine compliance with specifications or as a basis for mixture proportioning, evaluating uniformity of mixing, and checking placement operations by using sawed beams. It is used primarily in testing concrete for the construction of slabs and pavements.

4. Apparatus

4.1 *Testing Machine*—The testing machine shall conform to the requirements of the sections on Basis of Verification, Corrections, and Time Interval Between Verifications of Practices E4. Hand operated testing machines having pumps that do not provide a continuous loading in one stroke are not permitted. Motorized pumps or hand operated positive displacement pumps having sufficient volume in one continuous stroke to complete a test without requiring replenishment are

³ Tanesi, J; Ardani, A. Leavitt, J. "Reducing the Specimen Size of Concrete Flexural Strength Test (AASHTO T97) for Safety and Ease of Handling," *Transportation Research Record: Journal of the Transportation Research Board*, No. 2342, Transportation Research Board of National Academies, Washington, D.C., 2013.

⁴ Carrasquillo, P.M. and Carrasquillo, R. L. "Improved Concrete Quality Control Procedures Using Third Point Loading", *Research Report 119-1F*, Project 3-9-87-1119, Center For Transportation Research, The University of Texas at Austin, November 1987.

⁵ Bazant, Z. and Novak, D. "Proposal for Standard Test of Modulus of Rupture of Concrete with its Size Dependence," *ACI Materials Journal*, January-February 2001.

*A Summary of Changes section appears at the end of this standard

permitted and shall be capable of applying loads at a uniform rate without shock or interruption. The testing machine shall be equipped with a means of recording or holding the peak value that will indicate the maximum load, to within 1 % accuracy, applied to the specimen during a test.

4.2 *Loading Apparatus*—The third point loading method shall be used in making flexure tests of concrete employing bearing blocks that will ensure that forces applied to the beam will be perpendicular to the face of the specimen and applied without eccentricity. A diagram of an apparatus that accomplishes this purpose is shown in Fig. 1.

4.2.1 All apparatus for making flexure tests of concrete shall be capable of maintaining the specified span length and distances between load-applying blocks and support blocks constant within ± 1.0 mm [± 0.05 in.].

4.2.2 The ratio of the horizontal distance between the point of application of the load and the point of application of the nearest reaction to the depth of the beam shall be 1.0 ± 0.03 .

4.2.3 If an apparatus similar to that illustrated in Fig. 1 is used: the load-applying and support blocks shall not be more than 65 mm [2.50 in.] high, measured from the center or the axis of pivot, and should extend entirely across or beyond the full width of the specimen. Each case-hardened bearing surface in contact with the specimen shall not depart from a plane by more than 0.05 mm [0.002 in.] and shall be a portion of a cylinder, the axis of which is coincidental with either the axis of the rod or center of the ball, whichever the block is pivoted upon. The angle subtended by the curved surface of each block shall be at least 0.80 rad [45°]. The load-applying and support blocks shall be maintained in a vertical position and in contact with the rod or ball by means of spring-loaded screws that hold them in contact with the pivot rod or ball. The uppermost bearing plate and center point ball in Fig. 1 may be omitted

when a spherically seated bearing block is used, provided one rod and one ball are used as pivots for the upper load-applying blocks.

5. Test Specimens

5.1 The test specimen shall conform to all requirements of Test Method C42/C42M or Practices C31/C31M or C192/C192M applicable to beam specimens and shall have a test span within 2 % of being three times its depth as tested. The sides of the specimen shall be at right angles with the top and bottom. All surfaces shall be smooth and free of scars, indentations, holes, or inscribed identification marks.

5.2 Provided the smaller cross-sectional dimension of the beam is at least three times the nominal maximum size of the coarse aggregate, the modulus of rupture can be determined using different specimen sizes. However, measured modulus of rupture generally increases as specimen size decreases.^{3,4} (Note 1).

NOTE 1—The strength ratio for beams of different sizes depends primarily on the maximum size of aggregate.⁵ Experimental data obtained in two different studies have shown that for maximum aggregate size between 19.0 and 25.0 mm [$3/4$ and 1 in.], the ratio between the modulus of rupture determined with a 150 by 150 mm [6 by 6 in.] and a 100 by 100 mm [4 by 4 in.] may vary from 0.90 to 1.07³ and for maximum aggregate size between 9.5 and 37.5 mm [$3/8$ and 1 1/2 in.], the ratio between the modulus of rupture determined with a 150 by 150 mm [6 by 6 in.] and a 115 by 115 mm [4.5 by 4.5 in.] may vary from 0.86 to 1.00.⁴

5.3 The specifier of tests shall specify the specimen size and number of specimens to be tested to obtain an average test result (Note 2). The same specimen size shall be used for qualification and acceptance testing.

NOTE 2—It has been shown that the variability of individual test results increases as the specimen size decreases.^{3,4}

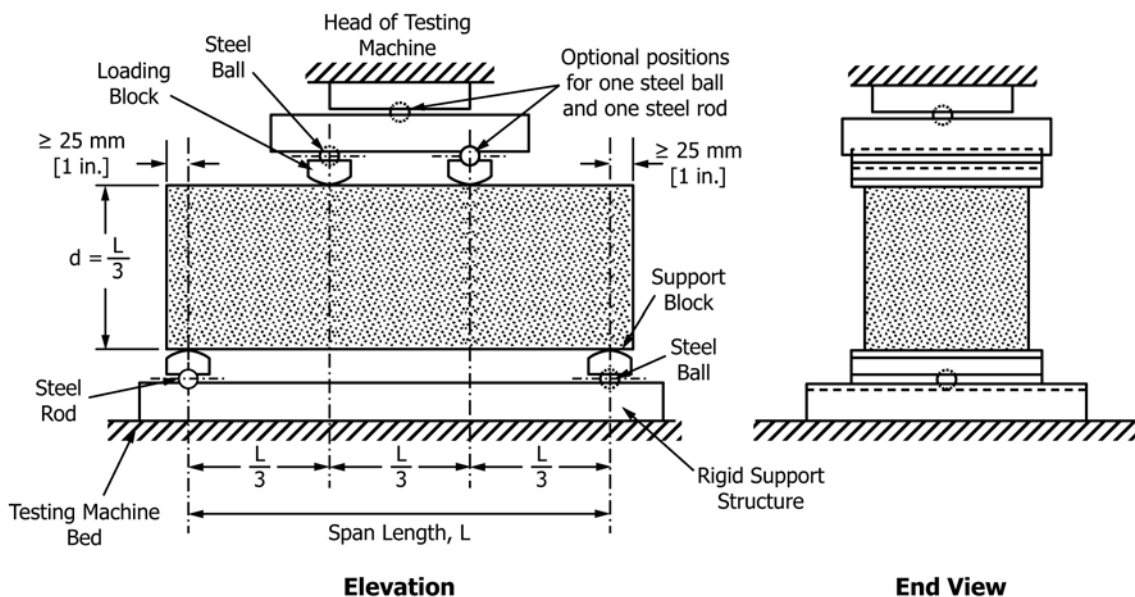

NOTE 1—This apparatus may be used inverted. If the testing machine applies force through a spherically seated head, the center pivot may be omitted, provided one load-applying block pivots on a rod and the other on a ball.

FIG. 1 Schematic of a Suitable Apparatus for Flexure Test of Concrete by Third-Point Loading Method