



Designation: D1217 – 15

Standard Test Method for Density and Relative Density (Specific Gravity) of Liquids by Bingham Pycnometer¹

This standard is issued under the fixed designation D1217; the number immediately following the designation indicates the year of original adoption or, in the case of revision, the year of last revision. A number in parentheses indicates the year of last reapproval. A superscript epsilon (ϵ) indicates an editorial change since the last revision or reapproval.

This standard has been approved for use by agencies of the U.S. Department of Defense.

1. Scope*

1.1 This test method covers the measurement of the density of pure hydrocarbons or petroleum distillates boiling between 90 °C and 110 °C that can be handled in a normal fashion as a liquid at the specified test temperatures of 20 °C and 25 °C.

1.2 This test method provides a calculation procedure for the conversion of density to relative density (specific gravity).

1.3 **WARNING**—Mercury has been designated by many regulatory agencies as a hazardous material that can cause central nervous system, kidney and liver damage. Mercury, or its vapor, may be hazardous to health and corrosive to materials. Caution should be taken when handling mercury and mercury containing products. See the applicable product Material Safety Data Sheet (MSDS) for details and EPA's website—<http://www.epa.gov/mercury/faq.htm>—for additional information. Users should be aware that selling mercury and/or mercury containing products in your state or country may be prohibited by law.

1.4 The values stated in SI units are to be regarded as standard. No other units of measurement are included in this standard.

1.5 *This standard does not purport to address all of the safety concerns, if any, associated with its use. It is the responsibility of the user of this standard to establish appropriate safety and health practices and determine the applicability of regulatory limitations prior to use.* Specific warning statements are given in Section 7.

¹ This test method is under the jurisdiction of ASTM Committee D02 on Petroleum Products, Liquid Fuels, and Lubricants and is the direct responsibility of Subcommittee D02.04.0D on Physical and Chemical Methods.

Current edition approved Dec. 1, 2015. Published February 2016. Originally approved in 1952. Last previous edition approved in 2012 as D1217 – 12. DOI: 10.1520/D1217-15.

2. Referenced Documents

2.1 *ASTM Standards:*²

D4052 Test Method for Density, Relative Density, and API Gravity of Liquids by Digital Density Meter

E1 Specification for ASTM Liquid-in-Glass Thermometers

3. Terminology

3.1 *Definitions:*

3.1.1 *density, n*—mass per unit volume at a specified temperature. **D4052**

3.1.2 *relative density, n*—the ratio of the density of a material at a stated temperature to the density of water at a stated temperature. **D4052**

4. Summary of Test Method

4.1 The liquid sample is introduced into a pycnometer, equilibrated to the desired temperature, and weighed. The relative density (specific gravity) or density is then calculated from this weight and the previously determined weight of water that is required to fill the pycnometer at the same temperature, both weights being corrected for the buoyancy of air.

5. Significance and Use

5.1 Density is a fundamental physical property which can be used in conjunction with other properties to characterize pure hydrocarbons and their mixtures.

5.2 This test method was originally developed for the determination of the density of the ASTM Knock Test Reference Fuels *n*-heptane and *isooctane*, with an accuracy of

² For referenced ASTM standards, visit the ASTM website, www.astm.org, or contact ASTM Customer Service at service@astm.org. For *Annual Book of ASTM Standards* volume information, refer to the standard's Document Summary page on the ASTM website.

*A Summary of Changes section appears at the end of this standard

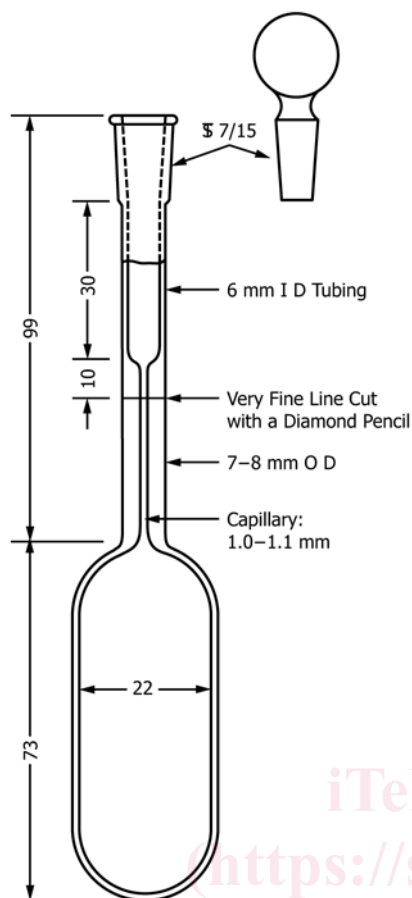

FIG. 1 Bingham-Type Pycnometer, 25 mL

0.00003 g/mL. Although it is no longer employed extensively for this purpose, this test method is useful whenever accurate densities of pure hydrocarbons or petroleum fractions with boiling points between 90 °C and 110 °C are required.

6. Apparatus

6.1 *Pycnometer*, Bingham-type,³ conforming to the dimensions given in Fig. 1, constructed of borosilicate glass, and having a total weight not exceeding 30 g.

6.2 *Constant-Temperature Bath*, provided with suitable pycnometer holders or clips and means for maintaining temperatures constant to ± 0.01 °C in the desired range.

6.3 *Bath Thermometer*, graduated in 0.1 °C subdivisions and standardized for the ice point and the range of use to the nearest 0.01 °C. ASTM Saybolt Viscosity Thermometer 17C as prescribed in Specification E1, designed for tests at 21.1 °C and 25 °C, is recommended. A standardized platinum resistance thermometer may also be used, and offers the best means for observing minute temperature changes in the bath. Whichever means are available, it must be realized that for most hydro-

carbons the density coefficient is about 0.0008 units/°C, and therefore an error of ± 0.013 °C would cause an error of ± 0.00001 in density.

6.4 *Hypodermic Syringe*, 30 mL capacity, of chemically resistant glass, equipped with a 152 mm needle made of stainless steel tubing as shown in Fig. 2.

6.5 *Draw-Off Needle*, made of stainless steel tubing as shown in Fig. 2.

6.6 *Solvent-Cleaning Assembly*, as shown in Fig. 3.

6.7 *Chromic Acid Cleaning Apparatus*, similar to that shown in Fig. 4.

6.8 *Balance*, capable of reproducing weighings within 0.1 mg. Mechanical balances should have sensitivity which causes the pointer to be deflected 2 or 3 scale divisions per 1 mg when carrying a load of 30 g or less on each pan. The balance should be located in a room shielded from drafts and fumes and in which the temperature changes between related weighings (empty and filled pycnometer) do not cause a significant change in the ratio of the balance arms. Otherwise weighings shall be made by the method of substitution, in which the calibrated weights and pycnometer are alternately weighed on the same balance pan. The same balance shall be used for all related weighings.

6.9 *Weights*, whose relative values are known to the nearest 0.05 mg or better. The same set of weights shall be used for the calibration of the pycnometer and the determination of densities.

7. Reagents and Materials

7.1 *Acetone*—(Warning—Extremely flammable. Use adequate ventilation.)

7.2 *Isopentane*—(Warning—Extremely flammable. Avoid buildup of vapors and remove all sources of ignition, especially non-explosion proof electrical apparatus.)

7.3 *Chromic Acid (Potassium Dichromate/Conc. Sulfuric Acid)*—(Warning—Causes severe burns. A recognized carcinogen. Do not get in eyes, or on skin or clothing.)

8. Preparation of Apparatus

8.1 Thoroughly clean the pycnometer with hot chromic acid cleaning solution by means of the assembly shown in Fig. 4. Chromic acid solution (Warning—See 7.3) is the most effective cleaning agent. However, surfactant cleaning fluids have also been used successfully. Mount the apparatus firmly and connect the trap to the vacuum. Warm the necessary amount of cleaning acid in the beaker, place the pycnometer on the ground joint, and evacuate by opening the stopcock to vacuum. Fill the pycnometer with acid by turning the stopcock, repeat several times or remove the filled pycnometer, and allow it to stand for several hours at 50 °C to 60 °C. Remove the acid from the pycnometer by evacuation, empty the acid from the trap, and flush the pycnometer with water. Cleaning should be made in this manner whenever the pycnometer is to be calibrated or whenever liquid fails to drain cleanly from the walls of the pycnometer or its capillary. Ordinarily, the

³ The sole source of supply of the pycnometer known to the committee at this time is Reliance Glass Co., 220 Gateway Rd., Bensenville, IL 60106-0825. If you are aware of alternative suppliers, please provide this information to ASTM International Headquarters. Your comments will receive careful consideration at a meeting of the responsible technical committee,¹ which you may attend.

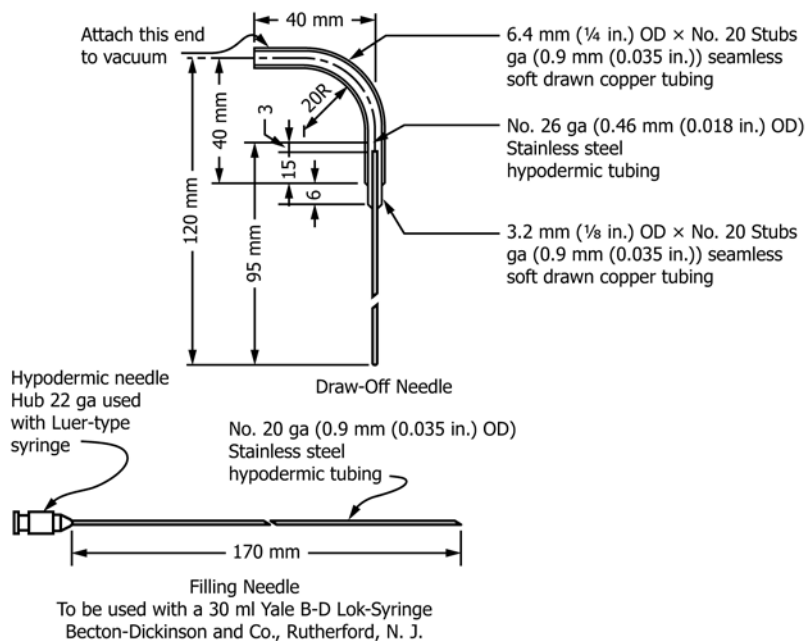

FIG. 2 Accessories for Bingham-Type Pycnometer

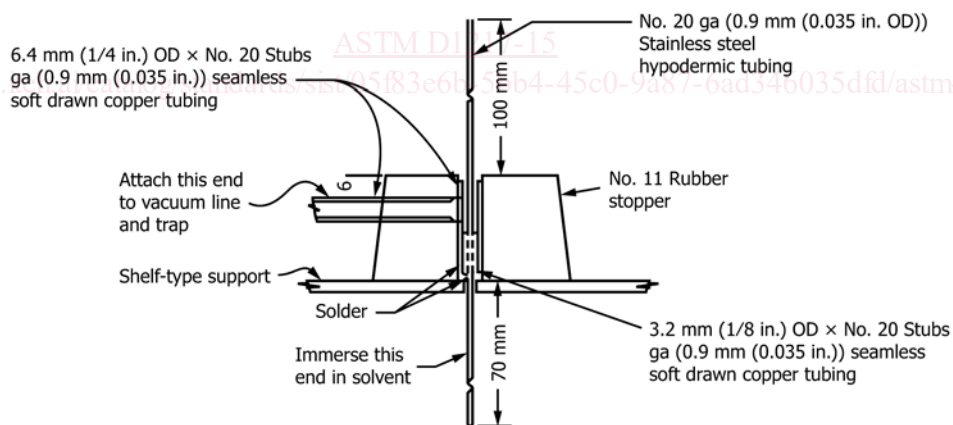
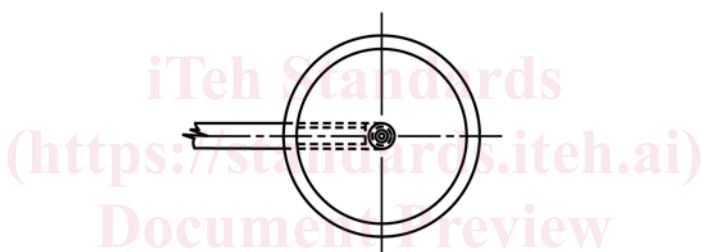

FIG. 3 Cleaner Assembly for Bingham-Type Pycnometer

pycnometer may be cleaned between determinations by washing with a suitable solvent, rinsing with pure, dry acetone, followed by isopentane, and vacuum drying.

8.2 Transfer the pycnometer to the cleaner assembly shown in Fig. 3, with vacuum line and trap attached to the side tube as indicated. Place the pycnometer on the cleaner with the upper hypodermic needle extending upward into the pycnometer, and press the edge of the ground joint on the rubber stopper until the vacuum holds it in place. Draw out all

the liquid or sample. Immerse the lower end of the hypodermic tube in a suitable solvent and draw 20 mL to 25 mL through the pycnometer. Leaving the pycnometer in place, draw air through it until it is dry. Clean the hypodermic syringe with the same apparatus.

9. Calibration of Pycnometer

9.1 Proceeding as directed in Section 10, determine the weight of freshly-boiled and cooled distilled water (distilled