



Standard Test Method for Behavior of Materials in a Tube Furnace with a Cone-shaped Airflow Stabilizer, at 750°C¹

This standard is issued under the fixed designation E2652; the number immediately following the designation indicates the year of original adoption or, in the case of revision, the year of last revision. A number in parentheses indicates the year of last reapproval. A superscript epsilon (ϵ) indicates an editorial change since the last revision or reapproval.

1. Scope-~~Scope~~*

1.1 This fire-test-response test method covers the determination under specified laboratory conditions of combustion characteristics of building materials.

1.2 Limitations of this fire-test response test method are shown below.

1.2.1 This test method does not apply to laminated or coated materials.

1.2.2 This test method is not suitable or satisfactory for materials that soften, flow, melt, intumesce or otherwise separate from the ~~measuring~~measuring thermocouple.

1.2.3 This test method does not provide a measure of an intrinsic property.

1.2.4 This test method does not provide a quantitative measure of heat generation or combustibility; it simply serves as a test method with selected (end point) measures of combustibility.

1.2.5 This test method does not measure the self-heating tendencies of materials.

1.2.6 In this test method materials are not being tested in the nature and form used in building applications. The test specimen consists of a small, specified volume that is either (1) cut from a thick sheet; (2) assembled from multiple thicknesses of thin sheets; or (3) placed in a container if composed of granular powder or loose fiber materials.

1.2.7 Results from this test method apply to the specific test apparatus and test conditions and are likely to vary when changes are made to one or more of the following: (1) the size, shape, and arrangement of the specimen; (2) the distribution of organic content; (3) the exposure temperature; (4) the air supply; (5) the location of thermocouples.

1.3 This test method references notes and footnotes that provide explanatory information. These notes and footnotes, excluding those in tables and figures, shall not be considered as requirements of this test method.

1.4 The values stated in SI units are to be regarded as standard. The values given in parentheses are for information only.

1.5 This test method is technically equivalent to ISO 1182 (see also [Annex A2](#) and [6.4.5](#)).

1.6 *This standard is used to measure and describe the response of materials, products, or assemblies to heat and flame under controlled conditions, but does not by itself incorporate all factors required for fire-hazard or fire-risk assessment of the materials, products, or assemblies under actual fire conditions.*

1.7 *Fire testing is inherently hazardous. Adequate safeguards for personnel and property shall be employed in conducting these tests.*

1.8 *This standard does not purport to address all of the safety concerns, if any, associated with its use. It is the responsibility of the user of this standard to establish appropriate safety and health practices and determine the applicability of regulatory limitations prior to use.*

2. Referenced Documents

2.1 *ASTM Standards:*²

[E136 Test Method for Behavior of Materials in a Vertical Tube Furnace at 750°C](#)

[E176 Terminology of Fire Standards](#)

¹ This test method is under the jurisdiction of ASTM Committee E05 on Fire Standards and is the direct responsibility of Subcommittee E05.23 on Combustibility. Current edition approved July 1, 2012; Jan. 1, 2016. Published August 2012; February 2016. Originally approved in 2009. Last previous edition approved in 2009 as E2652-09a-12. DOI: [10.1520/E2652-12](#); [10.1520/E2652-16](#).

² For referenced ASTM standards, visit the ASTM website, [www.astm.org](#), or contact ASTM Customer Service at [service@astm.org](#). For *Annual Book of ASTM Standards* volume information, refer to the standard's Document Summary page on the ASTM website.

*A Summary of Changes section appears at the end of this standard

2.2 ISO Standards:³

ISO 1182 Reaction to Fire Tests for Building Products – Non-combustibility Test

ISO 13943 Fire Safety — Vocabulary

ISO 5725-2:1994 Accuracy (trueness and precision) of Measured Methods and Results – Part 2: Basic Method for the Determination of Repeatability and Reproducibility of a Standard Measurement Method

2.3 Other Standards:⁴

IMO Fire Test Procedures Code

3. Terminology

3.1 *Definitions*—For definitions of terms found in this test method, refer to Terminology E176 and ISO 13943. In case of conflict, the definitions given in Terminology E176 shall prevail.

3.2 *Definitions of Terms Specific to This Standard:*

3.2.1 *homogeneous product, n*—a product with nominally uniform density and composition.

3.2.2 *non-homogeneous product, n*—a product that does not satisfy the requirements of a homogeneous product.

³ Available from American National Standards Institute (ANSI), 25 W. 43rd St., 4th Floor, New York, NY 10036, <http://www.ansi.org>.

⁴ Available from International Maritime Organization, 55 Victoria St., London, SW1H0EU, United Kingdom, <http://www.imo.org>.

3.2.2.1 Discussion—

Non-homogeneous products are often composed of more than one component.

3.2.3 *sustained flaming (for testing at 750°C), n*—sustained flaming for testing at 750°C (1382°F) is the persistence of a flame on or over any part of the visible part of the test specimen lasting 5 s or longer.

4. Summary of Test Method

4.1 This test method uses a furnace to expose building materials for at least 30 min to a temperature of 750°C (1382°F).

4.2 The furnace consists of an enclosed refractory tube surrounded by a heating coil with a cone-shaped airflow stabilizer.

4.3 Thermocouples are used to assess the temperature increases resulting from combustion of the product.

4.4 Weight loss and flaming combustion of the product is also assessed.

5. Significance and Use

5.1 While actual building fire exposure conditions are not duplicated, this test method will assist in indicating those materials which do not act to aid combustion or add appreciable heat to an ambient fire.

5.2 This test method does not apply to laminated or coated materials.

5.3 This test method is technically equivalent to ISO 1182.

6. Test Apparatus

6.1 *General:*

6.1.1 The apparatus shall consist of a refractory tube furnace insulated and surrounded by a heating coil. A cone-shaped airflow stabilizer shall be attached to the base of the furnace and a draft shield to its top. Details are shown in Fig. 1.

6.1.2 Thermocouples shall be provided for measuring the furnace temperature and the furnace wall temperature. Optional additional thermocouples shall be used if the specimen surface temperature and the specimen center temperature are required.

6.1.3 A thermal sensor shall be used to measure the furnace temperature along its central axis.

6.1.4 Unless stated otherwise, all dimensions shall have a 5 % tolerance.

6.2 *Test Furnace:*

6.2.1 The test furnace shall consist primarily of the following.

6.2.2 The furnace tube shall be constructed of a refractory material, as specified in Table 1, of density $2800 \pm 300 \text{ kg/m}^3$ ($175 \pm 19 \text{ lb/ft}^3$).

6.2.3 The furnace shall be $150 \pm 1 \text{ mm}$ ($5.9 \pm 0.04 \text{ in.}$) high with an internal diameter of $75 \pm 1 \text{ mm}$ ($2.9 \pm 0.04 \text{ in.}$) and a wall thickness of $10 \pm 1 \text{ mm}$ ($0.4 \pm 0.04 \text{ in.}$).

6.2.4 The furnace tube shall be surrounded by an annular space of the following dimensions: 150 mm ($5.9 \pm 0.04 \text{ in.}$) high and of 10 mm ($0.4 \pm 0.04 \text{ in.}$) wall thickness.

6.2.4.1 The annular space shall be fitted with top and bottom plates, recessed internally to locate the ends of the furnace tube.

6.2.4.2 The annular space shall be insulated with a 25 mm (1 in.) mm layer of an insulating material having a thermal conductivity of $0.04 \pm 0.01 \text{ W/(m K)}$ ($0.00077 \pm 0.00019 \text{ BTU in.}/(\text{s ft}^2 \text{ }^\circ\text{F})$) at a mean temperature of 20°C (68°F). Magnesium oxide powder of a nominal bulk density of $170 \pm 30 \text{ kg/m}^3$ ($10.6 \pm 1.9 \text{ lb/ft}^3$) is a suitable material for this use.

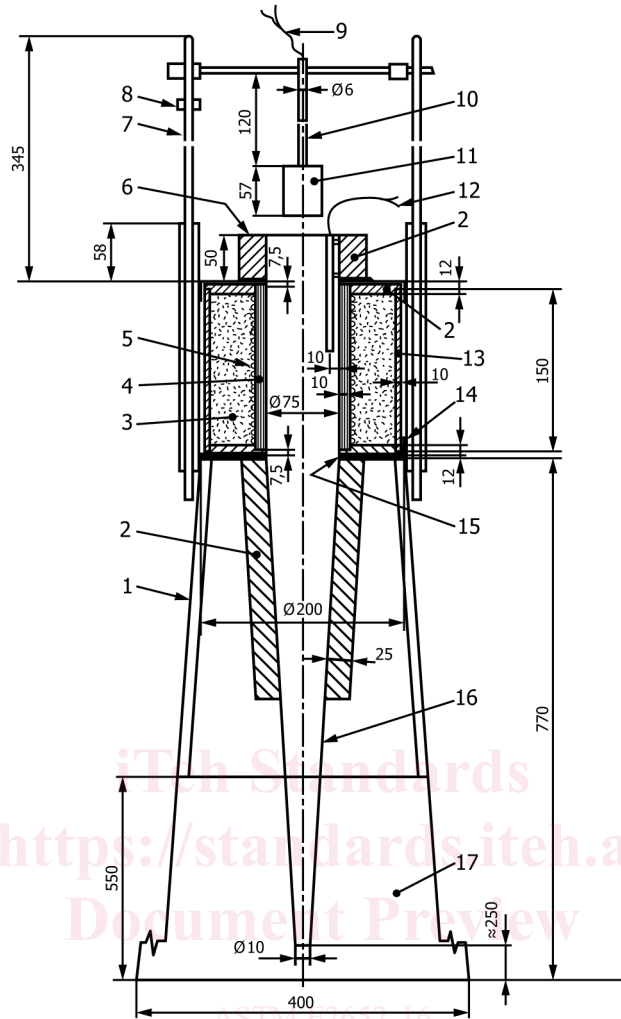

FIG. 1 Test Apparatus

Key to numbers in Fig. 1

- | | | |
|--------------------------|---|-------------------------------|
| 1 Stand | 7 Heat resisting steel rod for insertion device | 13 External insulating wall |
| 2 Insulation | 8 Stop | 14 Mineral fiber cement |
| 3 Magnesium oxide powder | 9 Specimen thermocouples (optional) | 15 Seal |
| 4 Furnace tube | 10 Stainless steel tube | 16 Stabilizer cone |
| 5 Heating coils | 11 Specimen holder | 17 Draft screen (metal sheet) |
| 6 Draft shield | 12 Furnace thermocouple | |

TABLE 1 Furnace Tube Refractory Material for Apparatus

Material	Composition % (kg/kg mass)
Alumina (Al ₂ O ₃)	>89
Silica and alumina (SiO ₂ , Al ₂ O ₃)	>98
Ferric oxide (Fe ₂ O ₃)	<0,45
Titanium dioxide (TiO ₂)	<0,25
Manganese oxide (Mn ₃ O ₄)	<0,1
Other trace oxides (sodium, potassium, calcium and magnesium oxides)	The balance

6.2.5 The furnace tube shall be provided with a single winding of 80/20 nickel/chromium electrical resistance tape, 3 mm ± 0.1 mm (0.12 ± 4/1000 in.) wide and 0.2 ± 0.01 mm (8/1000 ± 0.4/1000 in.) thick.

6.2.5.1 Wind the electrical resistance tape as specified in Fig. 2.

6.2.5.2 Cut grooves into the furnace tube so as to allow accurate winding of the electrical tape.

6.2.6 An open-ended cone-shaped air-flow stabilizer shall be attached to the underside of the furnace.

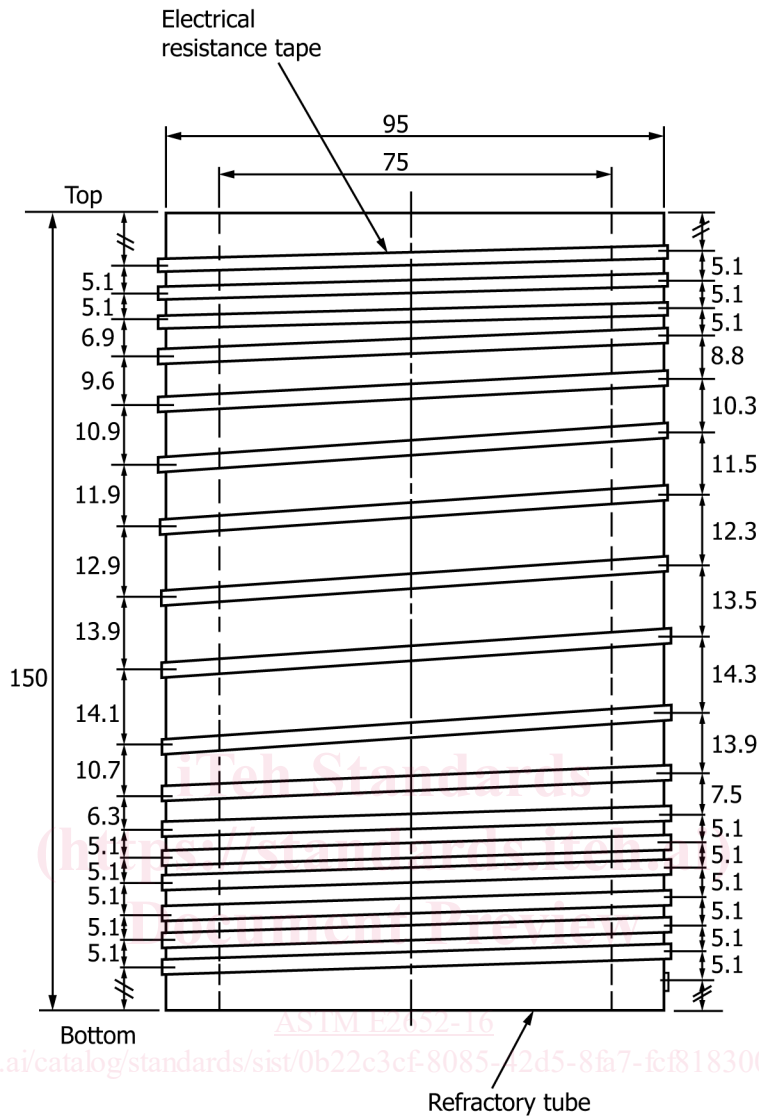

All dimensions in millimetres.

FIG. 2 Furnace Winding for Test Apparatus

6.2.6.1 The air-flow stabilizer shall be 500 mm (19.7 in.) long and shall be reduced uniformly from an internal diameter of 75 ± 1mm (2.9 ± 0.04 in.) at the top to an internal diameter of 10.0 ± 0.5 mm (0.4 ± 0.4 in.) at the bottom.

6.2.6.2 The air flow stabilizer shall be manufactured from 1 mm thick sheet steel, with a smooth finish on the inside. The joint between the air flow stabilizer and the furnace shall have an airtight fit, with an internal smooth finish.

6.2.6.3 The upper half of the air flow stabilizer shall be insulated with a 25 mm (1 in.) layer of an insulating material having a thermal conductivity of 0.04 ± 0.01 W/(m K) (0.00077 ± 0.00019 BTU in./(s ft² °F)) at a mean temperature of 20°C (68°F). Mineral fiber insulating material with a nominal thermal conductivity of 0.04 ± 0.01 W/(m K) (0.00077 ± 0.00019 BTU in./(s ft² °F)) at a mean temperature of 20°C (68°F) is a suitable material for this use.

6.2.7 A draft shield, constructed of the same material as the air flow stabilizer, shall be provided at the top of the furnace. It shall be 50 mm (2 in.) high and have an internal diameter of 75 ± 1 mm (2.9 ± 0.04 in.)

6.2.7.1 The draft shield and its joint with the top of the furnace shall have smooth internal finish.

6.2.7.2 The exterior shall be insulated with a 25 mm (1 in.) layer of an insulating material having a thermal conductivity of 0.04 ± 0.01 W/(m K) (0.00077 ± 0.00019 BTU in./(s ft² °F)) at a mean temperature of 20°C (68°F). Mineral fiber insulating material with a nominal thermal conductivity of 0.04 ± 0.01 W/(m K) (0.00077 ± 0.00019 BTU in./(s ft² °F)) at a mean temperature of 20°C (68°F) is a suitable material for this use.

6.2.8 The assembly, consisting of the furnace, air flow stabilizer cone and draft shield, shall be mounted on a firm horizontal stand, with a base and draft screen attached to the stand, to reduce drafts around the bottom of the stabilizer cone. The draft screen shall be 550 mm (21.7 in.) high and the bottom of the air flow stabilizer cone shall be located 250 mm (9.8 in.) above the base plate.

6.3 Test Specimen Holder and Insertion Device:

6.3.1 The test specimen holder shall be made of nickel/chromium or of an alternate heat-resisting steel wire. A fine metal gauze tray of heat-resisting steel shall be placed in the bottom of the holder. The weight of the holder shall be 15 ± 2 g (0.53 ± 0.07 oz).

6.3.2 The test specimen holder shall be capable of being suspended from the lower end of a stainless steel tube with a 6 mm ($\frac{1}{4}$ in.) outside diameter and a 4 mm (0.15 in.) bore, as shown in Fig. 3.

6.3.3 The test specimen holder shall be provided with a suitable insertion device for lowering it down the axis of the furnace tube without shock, so that the geometric center of the specimen during the test is located at the geometric center of the furnace, with a ± 3 mm ($\pm \frac{1}{8}$ in.) tolerance. The insertion device shall consist of a metallic sliding rod moving freely within a vertical guide fitted to the side of the furnace.

6.3.4 The test specimen holder for loose fill materials shall be cylindrical and shall have the same inner dimensions as the outer dimensions of the test specimen. It shall be made of fine metal wire gauze, constructed of heat resisting steel similar to the wire gauze used at the bottom of the test specimen holder specified in 6.3.1. The specimen holder shall have an open end at the top. The weight of the holder shall not exceed 30 g (1.06 oz).

6.4 Thermocouples:

6.4.1 Thermocouples shall have a wire diameter of 0.3 mm (0.01 in.) and an outer diameter of 1.5 mm (0.06 in.). The hot junction shall be insulated and not earthed. The thermocouples shall be of either type K or type N. The thermocouple insulating material shall be either stainless steel or a nickel based alloy.

6.4.2 All new thermocouples shall be exposed to a Bunsen burner yellow flame for not less than 60 s before use.

NOTE 1—This will reduce thermocouple reflectivity.

6.4.3 The furnace thermocouple shall be located with its hot junction 10.0 ± 0.5 mm (0.4 ± 0.04 in.) from the tube wall and at a height corresponding to the geometric center of the furnace tube. A locating guide is a useful tool to set the position of the thermocouple. The correct position shall be maintained with the help of a guide attached to the draft shield.

6.4.4 In addition to the thermocouple for the measurement of the furnace temperature, a similar thermocouple shall be provided for measuring the furnace wall temperature during calibration.

6.4.5 Optional thermocouples are described in Annex A2.

6.4.6 An optional mirror is described in Annex A2.

~~6.4.5 Optional Test Specimen Center Thermocouple—The optional test specimen center thermocouple shall be positioned so that its hot junction is located at the geometric center of the test; they are not to be utilized when testing is intended to comply with ISO 1182. See also Annex A2 specimen. This shall be achieved by drilling a 2 mm (0.08 in.) diameter hole axially in the top of the test specimen.~~

6.4.5.1 Test Specimen Center Thermocouple—The test specimen center thermocouple shall be positioned so that its hot junction is located at the geometric center of the test specimen. This shall be achieved by drilling a 2 mm (0.08 in.) diameter hole axially in the top of the test specimen.

6.4.5.2 Test Specimen Surface Thermocouple—The test specimen surface thermocouple shall be positioned so that its hot junction is in contact with the test specimen at mid-height of the test specimen at the start of the test. It shall be located diametrically opposite the furnace thermocouple.

~~6.4.8 Optional Test Specimen Surface Thermocouple—The optional test specimen surface thermocouple shall be positioned so that its hot junction is in contact with the test specimen at mid-height of the test specimen at the start of the test. It shall be located diametrically opposite the furnace thermocouple.~~

~~6.4.6 When the apparatus of Test Method E2652 is used to assess the behavior of building materials in accordance with Test Method E136, measurements shall be made using both of the optional thermocouples specified in 6.4.7 Annex A2 (test specimen center thermocouple) and 6.4.8 (test specimen surface thermocouple) of Test Method E2652. The values shall be reported as required in Section 15 of Test Method E136.~~

6.5 *Thermal Sensor*—The thermal sensor shall be constructed of a thermocouple of the type specified in 6.4, brazed to a copper cylinder 10.0 ± 0.2 mm (0.4 ± 0.001 in.) in diameter and 15.0 ± 0.2 mm (0.6 ± 0.001 in.) high.

6.6 *Mirror*—To facilitate observation of sustained flaming and for operator safety, it is advisable to provide a mirror above the apparatus, positioned so that it will not affect the test. A square mirror, 300 mm (11.8 in.) per side, at an angle of 30° to the horizontal, and placed 1 m (1.1 yd) above the furnace has been found suitable.

6.7 *Balance*—A balance with an accuracy of 0.01 g (0.004 oz) is required.

6.8 *Voltage Stabilizer*—A single-phase automatic voltage stabilizer, with a rating of not less than 1.5 kVA, shall be provided. It shall be capable of maintaining the accuracy of the output voltage within $\pm 1\%$ of the rated value, from zero to full load.

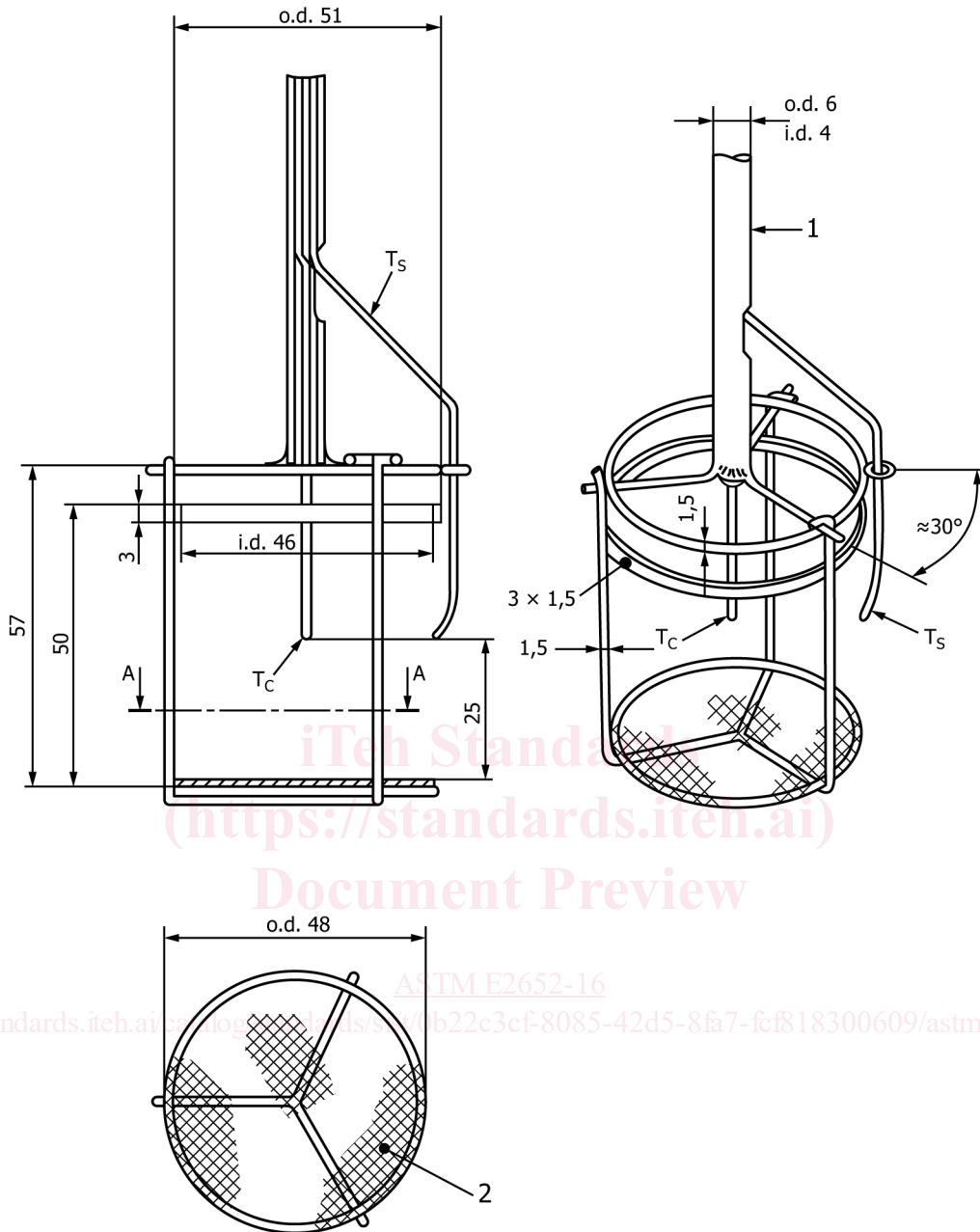

A-A
FIG. 3 Specimen Holder for Solid Specimens

Key

- 1 Stainless steel tube
- 2 Aperture mesh 0,9 mm diameter of wire 0,4 mm

Dimensions in millimetres

- T_c Specimen centre thermocouple
- T_s Specimen surface thermocouple
- Note – use of T_c and T_s is optional

6.9 *Variable Transformer*—A voltage transformer capable of handling at least 1.5 kVA and of regulating the voltage output from zero to a maximum value equal to that of the input voltage shall be provided. The voltage output shall vary linearly over the range.

6.10 *Electrical Input Monitor*—An ammeter and a voltmeter or wattmeter, shall be provided to enable rapid setting of the furnace to approximately the operating temperature.

6.11 *Power Controller*—A power controller shall be provided for use as an alternative to the voltage stabilizer, variable transformer and electrical input monitor specified above. It shall be of the type which incorporates phase-angle firing and shall be linked to a thyristor unit capable of supplying 1.5 VA. The maximum voltage shall not be greater than 100 V and the current limit