



Designation: ~~D7347 – 07~~^{ε1} D7347 – 15

Standard Test Method for Determination of Olefin Content in Denatured Ethanol by Supercritical Fluid Chromatography¹

This standard is issued under the fixed designation D7347; the number immediately following the designation indicates the year of original adoption or, in the case of revision, the year of last revision. A number in parentheses indicates the year of last reapproval. A superscript epsilon (ϵ) indicates an editorial change since the last revision or reapproval.

^{ε1} NOTE—Added research report footnote to Section 13 editorially in October 2008.

1. Scope-~~Scope~~*

1.1 This test method covers the determination of the total amount of olefins in denatured ethanol to be used as an oxygenate additive in blended spark ignition engine fuels. The method of determination is supercritical fluid chromatography (SFC). The application range is from 0.1 mass percent to 1.0 mass percent total olefins. Results are expressed in terms of mass percent olefins.

1.2 This test method can be used for the analysis of denatured ethanol that is intended to be used as an oxygenate additive in commercial spark ignition engine fuels.

1.3 The values stated in SI units are to be regarded as the standard. The values given in parentheses are for information only.

1.4 *This standard does not purport to address all of the safety concerns, if any, associated with its use. It is the responsibility of the user of this standard to establish appropriate safety and health practices and determine the applicability of regulatory limitations prior to use.*

2. Referenced Documents

2.1 *ASTM Standards*:²

[D4052 Test Method for Density, Relative Density, and API Gravity of Liquids by Digital Density Meter](#)

[D5186 Test Method for Determination of the Aromatic Content and Polynuclear Aromatic Content of Diesel Fuels and Aviation Turbine Fuels By Supercritical Fluid Chromatography](#)

[D6550 Test Method for Determination of Olefin Content of Gasolines by Supercritical-Fluid Chromatography](#)

3. Terminology

3.1 *Definitions*:

3.1.1 *critical pressure, n*—that pressure needed to condense a gas at the critical temperature.

3.1.2 *critical temperature, n*—highest temperature at which a gaseous fluid can be converted to a liquid by means of compression.

3.1.3 *supercritical fluid, n*—fluid maintained in a thermodynamic state above its critical temperature and critical pressure.

3.1.4 *supercritical fluid chromatography, n*—class of chromatography that employs supercritical fluids as mobile phases.

4. Summary of Test Method

4.1 A small aliquot of the denatured alcohol sample is injected onto a set of three analytical chromatographic columns connected in series. The sample is transported through the columns using supercritical carbon dioxide (CO₂) as the mobile phase. The first column is packed with polyvinyl alcohol (PVA). The second column in the series is an analytical column packed with high surface area silica gel particles, and the third column is packed with silica particles coated with strong cation exchange material loaded with silver ions.

¹ This test method is under the jurisdiction of ASTM Committee D02 on Petroleum Products, Liquid Fuels, and Lubricants and is the direct responsibility of Subcommittee D02.04.0C on Liquid Chromatography.

Current edition approved Aug. 1, 2007Dec. 1, 2015. Published September 2007February 2016. Originally approved in 2007. Last previous edition approved in 2007 as D7347 – 07¹. DOI: [10.1520/D7347-07E01](#); [10.1520/D7347-15](#).

² For referenced ASTM standards, visit the ASTM website, [www.astm.org](#), or contact ASTM Customer Service at [service@astm.org](#). For *Annual Book of ASTM Standards* volume information, refer to the standard's Document Summary page on the ASTM website.

*A Summary of Changes section appears at the end of this standard

4.2 Two six-port switching valves are used to direct the different classes of components through the chromatographic system to the detector. In a forward flow mode, saturates, aromatics, and olefins pass onto the analytical silica gel column while the alcohol is retained on the PVA column. The saturates, aromatics, and olefins are maintained on the silica column, while the alcohol is back-flushed to the detector. This step frees the flow path of alcohol species allowing for the separation of the olefins from saturates and aromatics. The forward flow mode is resumed after the alcohol is eliminated and saturates are carried to the detector, while the aromatics are retained on the silica column and the olefinic species are trapped on the silver-loaded column. The next step is to back-flush the olefins from the silver-loaded column to the detector. Finally the aromatics are carried from the silica column to the detector in a forward flow mode, bypassing the silver-loaded column.

4.3 A flame ionization detector (FID) is used for quantitation. Calibration is based on the area of the chromatographic signal for olefins, relative to standard reference materials, which contain a known mass percent of total olefins as corrected for density.

5. Significance and Use

5.1 Olefinic hydrocarbons that may be present in denatured ethanol have been demonstrated to contribute to photochemical reactions in the atmosphere, and this can result in the formation of smog in susceptible urban areas.

5.2 The California Air Resources Board (CARB) has specified a maximum allowable limit of total olefins in spark ignition engine fuel. Denatured ethanol will be added at the terminals as an oxygenate additive and can contain olefinic species contributing to the total olefins present in spark ignition engine fuel. An analytical method is therefore necessary to determine total olefins in denatured ethanol intended for spark ignition engine fuel use. The test method is intended to be used by both regulators and producers.

5.3 The present test method is automated, does not require any sample preparation, and has a relatively short analysis time of approximately 20 min.

6. Apparatus

6.1 *Supercritical Fluid Chromatograph (SFC)*—Any SFC instrumentation can be used that has the following characteristics and meets the performance requirements specified in Section 8.

NOTE 1—SFC instruments suitable for Test Method D6550 are suitable for this test method if equipped with a second column heater as described in 6.1.5.1 and columns as described in 6.1.4.

6.1.1 *Pump*—The SFC pump shall be able to operate at the required pressures (typically up to about ~~30 MPa~~) 30 MPa) and deliver a sufficiently stable flow to meet the requirements of retention time precision (better than ~~0.3%~~) 0.3 %) and detection background (Section 8). The characteristics of the pump largely determine the optimum column diameters. Columns with an inside diameter of ~~1.0 mm~~ 1.0 mm ID require a pump flow capacity of approximately ~~50 μ L/min~~ 50 μ L/min of liquid carbon dioxide, whereas columns with an inside diameter of ~~4.6 mm~~ 4.6 mm require a pump capacity of at least ~~1 mL/min~~ 1 mL/min of liquid carbon dioxide.

6.1.2 *Detectors*—A flame-ionization detector (FID) is required for quantitation. A flow restrictor shall be installed immediately before the FID. The restrictor serves to maintain the required pressure in the column, while allowing the pump and detector to perform as specified in 8.2.

6.1.3 *Sample Inlet System*—A liquid-sample injection valve is required that is capable of introducing a sub-microliter volume with a precision better than ~~0.5%~~ 0.5 %. A ~~0.200–0.200 μ L~~ to ~~0.060–0.060 μ L~~ injection volume was found to be adequate in combination with ~~1 mm~~ 1 mm diameter columns. The sample inlet system shall be installed and operated in a manner such that the chromatographic separation is not negatively affected.

6.1.4 *Columns*—Three columns of equal inside diameter are required:

6.1.4.1 A high surface area silica column, capable of separating alkanes and olefins from aromatics as specified in Section 8. Typically, a ~~50 cm~~ 50 cm long, ~~1 mm~~ 1 mm internal diameter, or a ~~25 cm~~ 25 cm, ~~4.6 mm~~ 4.6 mm internal diameter column is used. This column is packed with particles having an average diameter of ~~5 μ m~~ 5 μ m or less, ~~600 nm~~ (~~60 \AA~~) 600 nm (60 \AA) pores, and a surface area of ~~≥ 350 m²/g~~ ≥ 350 m²/g.

NOTE 2—Columns suitable for Test Method D5186 and D6550 are also suitable for this test method. Sources and typical dimensions are shown in Table 1.

6.1.4.2 A silver-loaded silica or cation exchange column capable of separating olefins from alkanes. Typically, a ~~5 cm~~ 5 cm long by ~~1 mm~~ 1 mm internal diameter column packed with particles having an average diameter of ~~5 μ m~~ 5 μ m is used for the analysis.

NOTE 3—Silver-loaded silica columns suitable for Test Method D6550 are also suitable for the present method. Sources and typical dimensions are shown in Table 1.

6.1.4.3 A ~~polyvinyl alcohol~~ polyvinyl alcohol (PVA) column capable of separating alkanes, olefins, and aromatics from alcohol. Typically, a ~~5 cm~~ 5 cm long by ~~1 mm~~ 1 mm or ~~4.6 mm~~ 4.6 mm internal diameter column packed with PVA particles is used for the analysis.

NOTE 4—PVA columns that have been used successfully are shown in Table 1.

TABLE 1 Typical Columns

Column Type:	PVA	Silica	Silver-loaded silica
Vendor:	Selerity, Waters Corporation	Selerity, Merck	Selerity, Hypersil, Phenomenex
Packing material:	PVA	High surface area silica particles	Cation exchange
Particle size, μm :	5	5	5
Length, mm:	50	500, 250	50
Internal diameter, mm:	1, 4.6	1, 4.6	1, 4.6

6.1.5 *Column-Temperature Control*—The chromatograph shall be capable of controlling column temperature to within $\pm 0.5^\circ\text{C}$ or less.

6.1.5.1 A secondary column heater mounted in the column chamber can be used to heat the silver-loaded column independently of the silica and PVA columns. This supplemental heating is recommended for faster clearance of the olefins and saturates from the silver-loaded column. The supplemental column heater box is typically maintained at $\pm 50^\circ\text{C}$ – 150°C .

6.1.6 *Computer or Electronic Integrator*—Means shall be provided for the determination of accumulated peak areas. This can be done by means of a computer or electronic integrator. The computer or integrator shall have the capability of correcting for baseline shifts during the run.

6.1.7 *Switching Valves*—Two six-way switching valves are configured in accordance with the scheme shown in Figs. 1-4. Four different positions are shown in these figures and are defined as follows:

6.1.7.1 *Position LC (Load Column)*—PVA column (forward flush mode), silver column (forward flush mode), and silica column (forward flush mode) connected in series. The flow enters the PVA column first, then the silica column second, and the silver-loaded silica column third. This position is used to (1) inject the sample onto the columns and (2) retain the alcohol on the PVA column while allowing all other species to pass onto the silica column. After the alcohol is flushed from the system in Position BE (back-flush ethanol) this position will again be used to (1) elute the saturates, (2) load the olefins onto the silver-loaded silica column, and (3) retain the aromatics on the silica column (see Fig. 1).

6.1.7.2 *Position BE (Back-Flush Ethanol)*—PVA column (back-flush mode). This position directs the flow from the PVA column to the detector. The silica and silver-loaded silica columns are not in the flow path. The alcohol is eluted in this position (see Fig. 2).

6.1.7.3 *Position BO (Back-Flush Olefins)*—The silica column is not in the flow path. The PVA (back-flush mode) and the silver-loaded silica (back-flush mode) columns are connected in series. The olefinic species are eluted in this position (see Fig. 3).

6.1.7.4 *Position EA (Elute Aromatics)*—PVA column (forward flush mode), silver column (forward flush mode), and silica column (forward flush mode) connected in series. The flow enters the PVA column first, then the silver-loaded silica column second, and the silica column third. This position differs from position LC in that the silica column is the last column in the series. The aromatics are eluted to the detector in the forward flow mode (see Fig. 4).

7. Reagents and Materials

7.1 *Air*—Zero-grade (hydrocarbon-free) air is used as the FID oxidant. (**Warning**—Air is usually supplied as a compressed gas under high pressure, and it supports combustion.)

7.2 *Calibration Solution*—An ethanolic mixture containing olefins of a known percent by mass % of the type found in typical denatured alcohol. An example of this mixture would be 99.50% – 99.50% ethanol, 99.995% – 99.995% purity and 0.50% – 0.50% olefin solution containing 2-pentene, 1-hexene and cyclohexene.

7.3 *Carbon Dioxide (CO₂)*—Supercritical fluid chromatographic grade, 99.995% – 99.995% minimum purity, supplied pressurized in a cylinder with a dip tube for removal of liquid through a CGA 320 fitting. (**Warning**—Liquid at high pressure. Release of pressure results in production of extremely cold, solid CO₂ and gas, which can dilute available atmospheric oxygen.)

7.4 *Hydrogen*—Hydrogen of high quality (hydrocarbon free) is used as the fuel for the FID. (**Warning**— Hydrogen is usually supplied under high pressure and is extremely flammable.)

7.5 *Loading-Time Mixtures*—Four loading time mixtures are recommended to determine the switching times for this test method and to protect the silica column from exposure to ethanol and the silver-loaded column from contamination by aromatics and ethanol.

7.5.1 *Loading-Time Mixture A*—A mixture of 10 % alkanes (n-hexane and cyclohexane), 10 % aromatics (benzene, toluene, and naphthalene), and 80 % ethanol can be used to determine the loading time of saturates, olefins, and aromatics onto the silica column while protecting the silica and silver-loaded column from ethanol contamination.

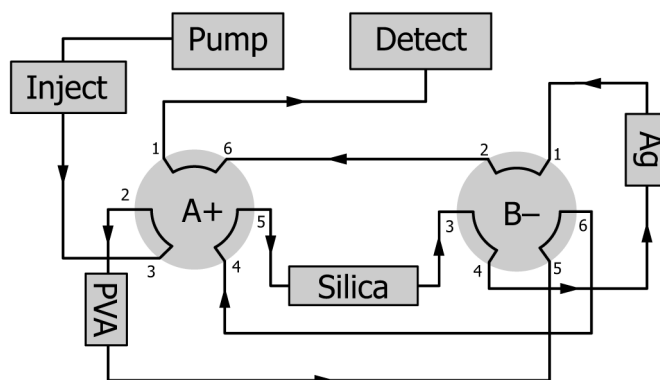

FIG. 1 Valve Position LC—Load Columns, Step 1 and 3

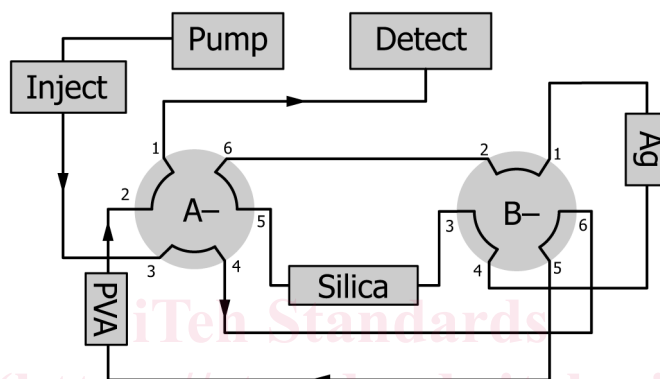

FIG. 2 Valve Position BE—Back-flush PVA, Step 2

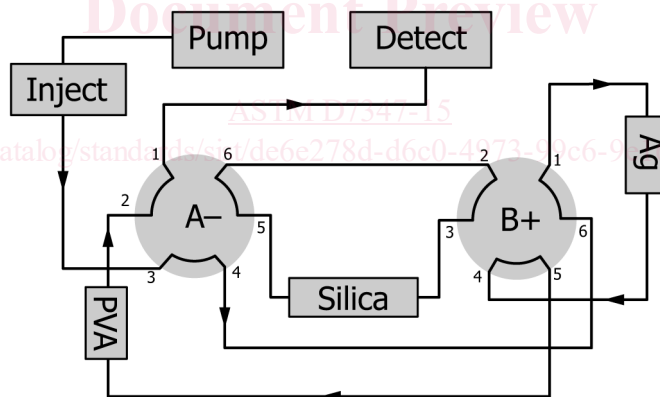

FIG. 3 Valve Position BO—Back-flush silver-loaded column, Step 4

7.5.2 *Loading-Time Mixture B*—A mixture of 10 % alkanes (*n*-hexane and cyclohexane), 7 % aromatics (benzene, toluene, and naphthalene), 3 % olefins (2-pentene, 1 hexene, and cyclohexene) and 80 % ethanol can be used to determine the loading time of saturates and olefins onto the silver-loaded column and protect it from aromatic contamination.

7.5.3 *Loading-Time Mixture C*—A mixture of 7 % alkanes (*n*-hexane and cyclohexane), 3 % olefins (2-pentene, 1-hexene, and cyclohexene), and 90 % ethanol can be used to establish the elution time of the olefins from the silver-loaded column to the detector in the back-flush mode.

7.5.4 *Loading-Time Mixture D*—A mixture of 10 % alkanes (*n*-hexane and cyclohexane) and 90 % ethanol can be used to check the absence of saturates on the silver-loaded column during the elution of olefins.

7.5.5 *Loading-Time Mixture E*—A mixture of 10 % aromatics (benzene, toluene, and naphthalene) and 90 % ethanol can be used to check the absence of aromatic contamination on the silver-loaded column.

7.6 *Purity of Reagents*—Reagent grade chemicals shall be used in all tests. Unless otherwise indicated, it is intended that all reagents conform to the specifications of the Committee on Analytical Reagents of the American Chemical Society where such

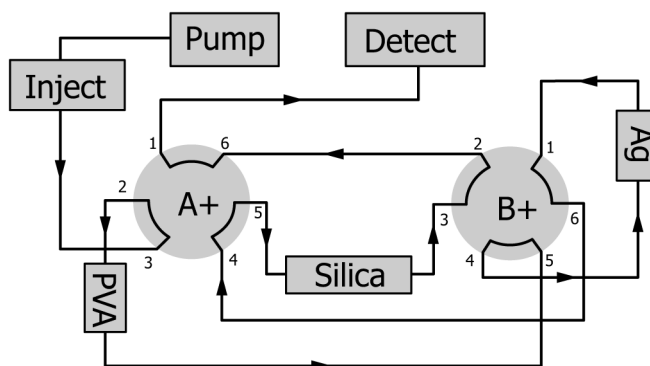

FIG. 4 Valve Position EA—High Resolution of Aromatics, Step 5

specifications are available.³ Other grades can be used, provided it is first ascertained that the reagent is of sufficiently high purity to permit its use without lessening the accuracy of the determination.

7.7 Performance Mixture—A mixture of alkanes (*n*-hexane and cyclohexane), mono-aromatics (benzene and toluene), and ~~poly-nuclear~~polynuclear aromatic (naphthalene) at no more than 10 % by weight and mono-olefins (2-pentene, ~~hexene~~, 1-hexene, and cyclohexene) at no more than 2 % by weight in chromatographic grade ethanol.

7.8 Quality Control Sample—A denatured alcohol containing olefins to be used to establish and monitor the precision of the analytical measurement system.

8. Preparation of Apparatus

8.1 Instrumentation—Install the SFC instrument in accordance with the manufacturer's instructions. System operating conditions will depend on the columns used and optimization of performance. The conditions listed in Table 2 have been used successfully. If the performance characteristics in terms of retention and resolution specified in 8.2 are not achieved, temperatures, pressure, or mobile-phase flow rate can be modified to achieve compliance.

System Performance

8.2 System Optimization—The operation of the SFC system shall be optimized in order to achieve the required separation on the silica column. Individual pure components and a performance mixture can be used to optimize the system.

8.3 Column Requirements:

8.3.1 Silica Column—The critical requirement for the silica column is the ability to achieve a quantitative separation of the olefins and saturates from the aromatics. The performance of this column is verified independently of the silver-loaded column by switching the valves to the appropriate positions (6.1.7.1 and 6.1.7.4). A sample containing alkanes (usually hexane), olefins and aromatics (preferably benzene) is injected in position LC (6.1.7.1) and is carried to the silica column (the time that it takes for the aromatic, saturates and olefins to be eluted onto the silica column can be determined by valve position BE (6.1.7.2)). Once the aromatics have been eluted onto the silica column, the valves are actuated to position EA (6.1.7.4) to bypass the silver-loaded column and elute the sample.

8.3.1.1 Resolution of Silica Column—The resolution (R_{ao}) between the olefinic compound and the aromatic compound in the performance mixture shall be at least four when measured as follows:

$$R_{ao} = \frac{2(t_a - t_o)}{1.699(y_a + y_o)} \quad (1)$$

where:

t_a = retention time for the aromatic reference compound, S,

t_o = retention time for the olefinic compound, S,

y_a = peak width at half height for the aromatic reference compound, S, and

y_o = peak width at half height for the olefinic reference compound, S.

8.3.2 Silver-Loaded Column—This column is used exclusively as an olefin trap. Its stability and chromatographic efficiency are not critical as long as the following are met: (1) the column shall allow quantitative separation of the saturates and the olefins, and (2) all olefins are quantitatively released under appropriate conditions. The performance of the silver-loaded column can be verified independently from that of the silica column by switching the valves to the appropriate position (6.1.7.3).

³ Reagent Chemicals, American Chemical Society Specifications, American Chemical Society, Washington, DC. For suggestions on the testing of reagents not listed by the American Chemical Society, see *Analar Standards for Laboratory Chemicals*, BDH Ltd., Poole, Dorset, U.K., and the *United States Pharmacopeia and National Formulary*, U.S. Pharmacopeial Convention, Inc. (USPC), Rockville, MD.

TABLE 2 Typical SFC Conditions

Parameter	Value
Pump pressure, atm	200
Temperature, °C	40
Injection volume, µL	0.06
FID temperature, °C	400, range 0
Secondary column heater temperature, °C	150 to 200
Air, mL/min	300
Hydrogen, mL/min	50
Analysis time, min	15 to 25

NOTE 5—Aromatic solutes should not be allowed to contact the silver-loaded column. This can be achieved by using a loading-time mixture that does not contain aromatics.

8.3.2.1 Using the performance mixture for optimization, no olefins shall elute from the silver-loaded column in the forward-flush mode in a time, t_{LAG} , defined as:

$$t_{LAG} = t_S + 5y_S \quad (2)$$

where:

t_S = retention time for the saturates reference compound, S , and
 y_S = peak width at half height for the saturates reference compound, S .

8.3.2.2 All olefins shall be released from the silver-loaded column in the back-flush mode within a time, t_{BFAg} , that is less than five times the total time during which the olefins are loaded onto the column in the forward-flush mode (t_{FFAg}), that is,

$$t_{BFAg} \leq 5t_{FFAg} \quad (3)$$

The elution of the olefins can be observed with the FID. Complete elution is considered to have occurred if the detector value (S_{End}) has returned to the baseline value observed before the elution of the saturates or olefins ($S_{Baseline}$), or both, to within 0.1% of the height of the olefins peak ($h_{Olefins}$), that is,

$$S_{End} \leq S_{Baseline} + h_{Olefins}/1000 \quad (4)$$

NOTE 6—It may be necessary to change the operating conditions in order to meet the requirement of Eq 3. Increasing the mobile-phase density or the column temperature may facilitate the elution of the olefins. However, the best precision can be achieved if the conditions are kept constant.

8.3.3 *Polyvinyl Alcohol Column*—This column is used exclusively as an alcohol trap. Its stability and chromatographic efficiency are not critical as long as the following requirements are met: (1) the column shall allow quantitative separation of the olefins and ethanol, and (2) all of the ethanol is quantitatively released under appropriate conditions. The performance of the PVA column can be verified independently from that of the silica and the silver-loaded column by switching the valves to the appropriate position (6.1.7.2).

NOTE 7—A loading-time mixture that contains ethanol, aromatics, and saturates can be used to measure the appropriate separation.

8.3.3.1 Using the performance mixture for optimization, no ethanol shall elute from the PVA column in the forward-flush mode in a time, t_{LP} , defined as:

$$t_{LP} = t_{SP} + 5X y_{SP} \quad (5)$$

where:

t_{SP} = retention time for the saturates reference compound, S , and
 y_{SP} = peak width at half height for the saturates reference compound, S .

8.3.3.2 All ethanol shall be released from the PVA column in the back-flush mode within a time, t_{BFP} , that is less than six times the total time during which the ethanol is loaded onto the column in the forward-flush mode (t_{FFP}), that is:

$$t_{BFP} \leq 6t_{FFP} \quad (6)$$

The total time t_{FF} is the sum of the loading time (t_L) and a cleaning time (t_C).

$$t_{FFP} = t_{LP} + t_{CP} \quad (7)$$

The absence of an FID signal at the end of the time t_C confirms proper separation of saturated, unsaturated, aromatic, and alcoholic compounds. The elution of the ethanol can be observed with the FID. Complete elution is considered to have occurred if the detector value (S_{End}) has returned to the baseline value observed before the elution of the ethanol ($S_{Baseline}$), or, to within 0.1% of the height of the ethanol peak ($h_{ethanol}$), that is,

$$S_{End} \leq S_{Baseline} + h_{ethanol}/1000 \quad (8)$$

NOTE 8—It may be necessary to change the operating conditions in order to meet the requirement of Eq 6. Increasing the mobile-phase density or the column temperature may facilitate the elution of the ethanol. However, the best precision can be achieved if the conditions are kept constant.

8.4 Retention-Time Precision: