



Designation: **E2191/E2191M – 10 E2191/E2191M – 16**

Standard Practice for Examination of Gas-Filled Filament-Wound Composite Pressure Vessels Using Acoustic Emission¹

This standard is issued under the fixed designation E2191/E2191M; the number immediately following the designation indicates the year of original adoption or, in the case of revision, the year of last revision. A number in parentheses indicates the year of last reapproval. A superscript epsilon (ϵ) indicates an editorial change since the last revision or reapproval.

1. Scope—Scope*

1.1 This practice provides guidelines for acoustic emission (AE) examination of filament-wound composite pressure vessels, for example, the type used for fuel tanks in vehicles which use natural gas fuel.

1.2 This practice requires pressurization to a level equal to or greater than what is encountered in normal use. The tanks' pressurization history must be known in order to use this practice. Pressurization medium may be gas or liquid.

1.3 This practice is limited to vessels designed for less than ~~690275~~ bar [~~10,000~~4,000 psi] maximum allowable working pressure and water volume less than 1 m³ or 1000 L [35.4 ft³].

1.4 AE measurements are used to detect emission sources. Other nondestructive examination (NDE) methods may be used to gain additional insight into the emission source. Procedures for other NDE methods are beyond the scope of this practice.

1.5 This practice applies to examination of new and ~~in-service~~ in-service, Type II, filament-wound composite pressure vessels.

1.6 This practice applies to examinations conducted at ambient temperatures above 20°C [70°F]. This practice may be used at ambient temperatures below 20°C [70°F] if provision has been made to fill to the tank's rated pressure at 20°C [70°F]. Also that the test temperature must not exceed the glass transition temperature of the matrix material.

1.7 *Units*—The values stated in either SI units or inch-pound units are to be regarded separately as standard. The values stated in each system may not be exact equivalents; therefore, each system shall be used independently of the other. Combining values from the two systems may result in non-conformance with the standard.

1.8 *This standard does not purport to address all of the safety concerns, if any, associated with its use. It is the responsibility of the user of this standard to establish appropriate safety and health practices and determine the applicability of regulatory limitations prior to use.* Specific precautionary statements are given in Section 8.

2. Referenced Documents

2.1 ASTM Standards:²

[E543 Specification for Agencies Performing Nondestructive Testing](#)

[E650 Guide for Mounting Piezoelectric Acoustic Emission Sensors](#)

[E976 Guide for Determining the Reproducibility of Acoustic Emission Sensor Response](#)

[E1316 Terminology for Nondestructive Examinations](#)

[E2374 Guide for Acoustic Emission System Performance Verification](#)

2.2 Natural Gas Vehicle Standard:³

[American National Standard for Basic Requirements for Compressed Natural Gas Vehicle \(NGV\) Fuel Containers ANSI/AGA/NGV2](#)

2.3 Compressed Gas Association Standard:⁴

[Pamphlet C-6.4, Methods for Visual Inspection of AGA NGV2 Containers](#)

¹ This practice is under the jurisdiction of ASTM Committee E07 on Nondestructive Testing and is the direct responsibility of Subcommittee E07.04 on Acoustic Emission Method.

Current edition approved ~~June 1, 2010~~Feb. 1, 2016. Published ~~July 2010~~February 2016. Originally approved in 2002. Last previous edition approved in ~~2008~~2010 as E2191-08-E2191 - 10. DOI: ~~10.1520/E2191-E2191M-10~~10.1520/E2191_E2191M-16.

² For referenced ASTM standards, visit the ASTM website, www.astm.org, or contact ASTM Customer Service at service@astm.org. For *Annual Book of ASTM Standards* volume information, refer to the standard's Document Summary page on the ASTM website.

³ Available from American National Standards Institute (ANSI), 25 W. 43rd St., 4th Floor, New York, NY 10036, <http://www.ansi.org>.

⁴ Available from Compressed Gas Association (CGA), 4221 Walney Rd., 5th Floor, Chantilly, VA 20151-2923, <http://www.cganet.com>.

*A Summary of Changes section appears at the end of this standard

2.4 *U.S. Department of Transportation Reference:*⁵

NHTSA Federal Motor Vehicle Safety Standard No. 304, March 27, 1995

2.5 *ASNT Standards:*⁶

ANSI/ASNT CP-189, Standard for Qualification and Certification of Nondestructive Testing Personnel
SNT-TC-1A, Recommended Practice for Nondestructive Testing Personnel Qualification and Certification

2.6 *International Standards Organization (ISO) Standards:*⁷

ISO 9712 Nondestructive Testing—Qualification and Certification of NDT Personnel

3. Terminology

3.1 *Definitions*—See Terminology E1316 for general terminology applicable to this practice.

3.2 *Definitions of Terms Specific to This Standard:*

3.2.1 *AE test pressure, n*—110 % of the greatest pressure that the examination article contains during previous service. Usually 125 % of the filling pressure is an acceptable AE examination pressure. (Normally, gas is heated when compressed during the filling process; hence, tanks are filled to more than rated service pressure). After filling, pressure should settle to rated service pressure as gas temperature within the tank becomes equal to ambient temperature.

3.2.2 *detectability distance, n*—the maximum distance from a sensor at which a defined simulated AE source can be detected by the instrumentation with defined settings and using appropriate pressurization medium.

4. Summary of Practice

4.1 AE sensors are mounted on a vessel and emission is monitored while the vessel is pressurized to the “AE examination pressure.”

4.2 This practice provides guidelines for the detection of AE from structural flaws in the composite overwrap in gas-filled, filament-wound composite pressure vessels. Damage mechanisms which produce AE include: resin cracking, fiber debonding, fiber pullout, fiber breakage, delamination and bond failure. Flaws in liner portions of a vessel may not be detected.

4.3 This practice and others found in ASTM, ASME, ASNT, SPI relate Acoustic Emission to applied load on the composite material. At relatively low load (safe operating conditions) the acoustic emission from the composite material is low. At higher loads (unsafe operating conditions) the slope of the AE versus load curve changes drastically. In some cases this phenomenon can be identified and quantified by a single AE parameter (that is, AE counts).

4.4 Structurally insignificant flaws or processes (for example, leaks) may produce emission.

4.5 This practice is convenient for periodic examination of vessels in-service.

4.6 Gas-filled filament-wound pressure vessels which exhibit unacceptable levels of AE should be examined by other methods; for example, visual, ultrasound, dye penetrant, etc., and may be repaired and re-examined in accordance with government regulations and manufacturers guidelines. Repair and repair examination procedures are outside the scope of this practice.

4.7 Any number of pressure vessels may be examined simultaneously as long as the appropriate number of sensors and instrumentation channels are used.

5. Significance and Use

5.1 Due to safety considerations, the Compressed Gas Association (CGA) and others have produced guidelines which address in-service inspection of NGV fuel containers (see 2.2 – 2.4). AE examination is listed as an alternative to the minimum three-year visual examination which generally requires that the container be removed from the vehicle to expose the entire container surface. The AE method allows “in-situ” examination of the container.

5.1.1 Slow-fill pressurization must proceed at flow rates that do not produce background noise from flow of the pressurizing medium. Acoustic emission data are recorded throughout a pressurization range (that is, 50 % to 100 % of AE examination pressure).

5.1.2 Fast-fill pressurization can be used if hold periods are provided. Acoustic emission data are recorded only during the hold periods.

NOTE 1—Fast-fill pressurization is less appropriate for carbon (or graphite) composites due to the lower sensitivity of carbon fibers to stress rupture compared to other fibers.

5.1.3 Background noise above the threshold will contaminate the AE data and render them useless. Users must be aware of the following common causes of background noise: high fill rate (measurable flow noise); mechanical contact with the vessel by

⁵ Available from Standardization Documents Order Desk, DODSSP, Bldg. 4, Section D, 700 Robbins Ave., Philadelphia, PA 19111-5098, <http://www.dodssp.daps.mil>.

⁶ Available from American Society for Nondestructive Testing (ASNT), P.O. Box 28518, 1711 Arlingate Ln., Columbus, OH 43228-0518, <http://www.asnt.org>.

⁷ Available from International Organization for Standardization (ISO), ISO Central Secretariat, BIBC II, Chemin de Blandonnet 8, CP 401, 1214 Vernier, Geneva, Switzerland, <http://www.iso.org>.

objects; electromagnetic interference (EMI) and radio frequency interference (RFI) from nearby broadcasting facilities and from other sources; leaks at pipe or hose connections and airborne particles, insects, rain and snow. This practice should not be used if background noise cannot be eliminated or controlled.

5.2 Sensitivity is influenced by factors that affect elastic wave propagation, sensor coupling and signal processor settings.

5.3 It is possible to measure AE from AE sources that cannot be verified by other NDE methods.

6. Basis of Application

6.1 The following items are subject to contractual agreement between the parties using or referencing this practice.

6.2 *Personnel Qualification*—If specified in the contractual agreement, personnel performing examinations to this practice shall be qualified in accordance with a nationally or internationally recognized NDT personnel qualification practice or standard such as ANSI/ASNT-CP-189, SNT-TC-1A, ISO 9712, or a similar document and certified by the employer or certifying agency, as applicable. The practice or standard used and its applicable revision shall be identified in the contractual agreement between the using parties.

6.3 *Qualification of Nondestructive Test Agencies*—If specified in the contractual agreement, NDT agencies shall be qualified and evaluated as described in Practice E543. The applicable edition of Practice E543 shall be specified in the contractual agreement.

6.4 *Extent of Examination*—The extent of examination shall be in accordance with 4.2 unless otherwise specified.

6.5 *Reporting Criteria/Acceptance Criteria*—Reporting criteria for the examination results shall be in accordance with Section 11 unless otherwise specified.

6.6 *Personnel Training/Test Requirements*—NDE personnel (examiner) shall be familiar with CGA Pamphlet C6 and shall have attended a training course and passed a written test which cover the following topics.

6.6.1 Basic technology of acoustic emission.

6.6.2 Failure mechanisms of reinforced plastics.

6.6.3 Acoustic emission instrumentation.

6.6.4 Instrumentation verification.

6.6.5 Vessel filling requirements.

6.6.6 Data collection and interpretation.

6.6.7 Examination report generation.

7. Apparatus

7.1 Essential features of the apparatus required for this standard are shown in Fig. 1. Specifications are provided in Annex A1.

7.2 Couplant must be used to acoustically couple sensors to the vessel surface. Adhesives that have acceptable acoustic properties and traditional couplants are acceptable.

7.3 Sensors may be held in place with elastic straps, adhesive tape, or other mechanical means.

7.4 On small vessels (that is, where less than 1.3 yd^3 [1 m^3] (where 100 % coverage can be achieved with two sensors) the sensor locations on the vessel wall will be determined by accessibility. Ideally they should be placed 180° apart at opposite ends of the container on the shoulders.

7.5 On larger vessels (that is, where two sensors cannot provide 100 % coverage) sensors are positioned on the vessel wall so as to provide complete coverage. Sensor spacings are governed by the attenuation of the material. If attenuation characteristics are not available from previous examinations of similar vessels follow the directions found below.

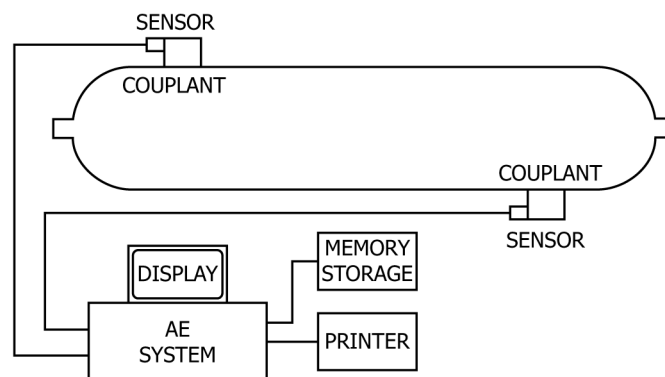

FIG. 1 Essential Features of the Apparatus

7.5.1 *Attenuation Characterization*—Typical signal propagation losses shall be determined in accordance with the following procedure. This procedure provides a relative measure of the attenuation but may not be representative of a genuine AE source. It should be noted that peak amplitude caused by a mechanical pencil lead break may vary with surface hardness, resin condition and cure. Select a representative region of the vessel with clear access along the cylindrical section. Mount an AE sensor and mark off 15-cm [6-in.] intervals from the center of the sensor along a line parallel to the principal direction of the surface fiber. Select additional points on the surface of the vessel at 15-cm [6-in.] intervals along lines angled 45° and 90°, respectively, to the principal direction of the surface fiber. Break pencil leads (see Guide E976) and record peak amplitude. All lead breaks shall be done at an angle of approximately 30° to the surface with a 2.5-mm [0.1-in.] lead extension. The attenuation data shall be retained as part of the test report.

7.5.2 Record the distances from the center of the sensor to the points where hits are no longer detected. Repeat this procedure along lines angled 45° and 90° to the direction of the original line. The data shall be retained as part of the test report. The minimum distance from the sensor at which the pencil lead break can no longer be detected is known as the detectability distance; this distance shall be recorded. Use the same threshold during testing that was used to determine the detectability distance.

NOTE 2—Detectability distance may be reduced to achieve greater sensitivity to sources at farther distance.

7.5.3 Sensor spacing (distance between adjacent sensors) shall not be greater than 1.5 times the detectability distance.

7.6 AE sensors are used to detect stress waves produced by flaws. Sensors must be held in contact with the vessel wall to ensure adequate acoustic coupling.

7.7 A preamplifier may be enclosed in the sensor housing or in a separate enclosure. If a separate preamplifier is used, cable length, between sensor and preamplifier, must not result in a signal loss of greater than 3 dB (typically 2 m [6 ft] is acceptable).

7.8 Power/signal cable length (that is, cable between preamplifier and signal processor) shall not result in a signal loss of greater than 3 dB (typically 150 m [500 ft] is acceptable).

7.9 ~~Signal processors~~ AE systems are computerized instruments with independent channels that filter, measure and convert analog information into digital form for display and permanent storage. ~~A signal processor~~ An AE system must have sufficient speed and capacity to independently process data from all sensors simultaneously. ~~The signal processor~~ AE system should provide capability to filter data for replay.

7.10 ~~A video monitor display~~ is used to ~~display~~ visually present processed data in various formats. Display format may be selected by the examiner.

7.11 ~~A data storage device, such as a magnetic disk, device~~ is used to store data for replay or for ~~archives~~ archive purposes.

7.12 Hard-copy capability should be available from a ~~graphics/line printer or equivalent device~~ printer.

8. Safety Precautions

8.1 Ambient temperature should not be below the ductile-brittle transition temperature of the pressure vessel liner.

9. Calibration and Verification

9.1 Annual calibration and verification of pressure transducer (if applicable), AE sensors, preamplifiers (if applicable), signal processor (particularly the signal processor time reference), and AE electronic waveform generator should be performed. Equipment should be adjusted so that it conforms to equipment manufacturer's specifications. Instruments used for calibrations must have current accuracy certification that is traceable to the National Institute for Standards and Technology (NIST).

9.2 Routine electronic evaluations must be performed on a monthly basis or at any time there is concern about signal processor performance. An AE electronic waveform generator should be used in making evaluations. Each signal processor channel must respond with peak amplitude reading within ± 2 dB of the electronic waveform generator output.

9.3 Routine performance ~~checking~~ evaluations of each sensor should be conducted on a monthly basis or at any time there is concern about the sensor performance. Peak amplitude response and electronic noise level should be recorded. Sensors can be stimulated by a pencil lead break or electronic waveform generator with a pulser. Sensors which are found to have peak amplitudes or electronic noise more than 3 dB greater or less than the average of the group of sensors to be used during the examination should be replaced.

9.4 A system verification must be conducted immediately before and immediately after each examination. A verification uses a mechanical device to induce stress waves into the vessel wall at a specified distance from each sensor. The induced stress waves simulate emission from a flaw. Performance checks verify performance of each system channel including couplant. See Guide E2374.

9.4.1 The preferred technique for conducting a verification is a pencil lead break. Lead should be broken on the vessel surface at a specified distance from the sensor (see Figure 4 of Guide E976).

9.4.2 System channels which are found to have performance outside of specified values should be repaired or replaced.

10. Procedure

10.1 Visually examine accessible exterior surfaces of the vessel. Note observations in the examination report (see CGA Pamphlet C-6.4).

10.2 Visually examine the tank exterior surface and remove any objects which come into contact. When vessel cannot be completely isolated, record in the examination report external sources which could have produced emission.

10.3 Connect fill hose (and pressure transducer if used). Eliminate any leaks at connections.

10.4 Mount acoustic emission sensors. Use procedures specified in Section 7 and in Guide E650.

10.5 Adjust signal processor (see Table X1.1).

10.6 Perform system verification at each sensor. Verify that peak amplitude is greater than a specified value (see Table X1.1). Details relating to a mechanical device that is used to produce stress waves are found in 9.4 and in Table X1.1. Prior to pressurization, verify that there is no background noise above the signal processor threshold setting (see Table X1.1).

NOTE 3—If desired sensitivity cannot be attained with sensors at two locations, more sensors must be used to provide complete coverage (see 7.4 and 7.5).

10.7 Begin pressurizing vessel. Fast-fill or slow-fill pressure schedule may be used (see Annex A2 and Annex A3).

10.8 Monitor test by observing displays that show plots of AE activity versus time or pressure. If unusual response is observed, interrupt pressurization and conduct an investigation to determine the cause.

10.9 Store all data on mass storage media. Stop the examination when pressure reaches AE examination pressure.

10.10 Compare the data to acceptance criteria and record results (see Appendix X1).

10.11 Vessels which have produced excessive emission may be re-examined immediately.

10.12 Carry out the system verification at each sensor (see 9.4). Verify that peak amplitude is greater than a specified value (see Table X1.1).

11. Report

11.1 Prepare a written report for each examination. Reports should contain the following information:

11.1.1 Name of owner of vessel and vehicle number (if appropriate).

11.1.2 Examination date and location.

11.1.3 Previous examination date and previous maximum examination pressure. See Note 4.

NOTE 4—If the examiner is aware of situations where the vessel was subject to pressures that exceeded normal fill pressure or incidents during handling or collisions involving a vehicle in which the examination article was mounted, these should be described in the report.

11.1.4 Record all information printed on the vessel.

11.1.5 Any DOT exemption numbers that apply to the vessel.

11.1.6 Normal fill pressure and marked service pressure.

11.1.7 Pressurization medium.

11.1.8 Pressure at which data acquisition commenced.

11.1.9 Maximum examination pressure.

11.1.10 Attenuation data (see 7.5.1).

11.1.11 Model of sensors used.

11.1.12 Model of AE instrumentation and settings (including bandpass filtering and threshold).

11.1.13 Signature of examiner.

11.1.14 Sketch which shows relative locations of vessels (if multiple vessels are being examined) and which shows sensor locations.

11.1.15 Pre-examination and post-examination system verification results.

11.1.16 Visual examination results.

11.1.17 AE examination results.

12. Keywords

12.1 acoustic emission; composite gas cylinders; composite pressure vessel; flaws; gas pressure vessels; NGV tanks



ANNEXES

(Mandatory Information)

A1. INSTRUMENTATION SPECIFICATIONS

A1.1 Sensors

A1.1.1 ~~AE broadband or resonant~~ sensors shall have high sensitivity somewhere within the 20 to 1200 kHz frequency band.

A1.1.2 Peak sensitivity shall be greater than ~~-85~~70 dB_{ΔE} (referred to 1V/ μ bar, determined by face-to-face ultrasonic method) in the frequency range of 20 ~~from a PLB source (as described in subsection 4.3.3 of Guide E976 to 1200 kHz).~~

A1.1.3 Sensor sensitivity shall not vary more than 3 dB over the intended range of temperatures in which sensors are used.

A1.1.4 Sensors shall be shielded against electromagnetic interference through proper design practice or differential (anti-coincidence) element design, or both.

A1.1.5 Sensors shall be electrically isolated from conductive surfaces by means of a shoe (a wear plate).

A1.2 Signal Cable

A1.2.1 The sensor signal cable which connects sensor and preamplifier shall not be longer than what will result in a 3 dB signal loss (typically 2 m [6 ft]). Integral preamplifier sensors meet this requirement. They have inherently short, internal, signal cables.

A1.2.2 Signal cable shall be shielded against electromagnetic interference. Standard coaxial cable is generally adequate.

A1.3 Couplant

A1.3.1 Couplant shall provide adequate acoustic coupling throughout the examination.

A1.3.2 Couplant must be temperature stable over the temperature range intended for use.

A1.3.3 Adhesives may be used if they satisfy acoustic coupling and temperature stability requirements.

A1.4 Preamplifier

A1.4.1 Preamplifier shall have noise level no greater than 7 μ V rms (referred to a shorted input) within the bandpass range.

A1.4.2 Preamplifier gain shall vary no more than ± 1 dB within the frequency band and temperature range of use.

A1.4.3 Preamplifier shall be shielded from electromagnetic interference.

A1.4.4 Preamplifiers of differential design shall have a minimum of 40 dB common mode rejection.

A1.4.5 The combination of preamplifier and signal processor shall include a bandpass filter with a minimum of 24 dB/octave signal attenuation above and below frequency band which is used.