



Designation: **D4253—14 D4253 – 16**

## Standard Test Methods for Maximum Index Density and Unit Weight of Soils Using a Vibratory Table<sup>1</sup>

This standard is issued under the fixed designation D4253; the number immediately following the designation indicates the year of original adoption or, in the case of revision, the year of last revision. A number in parentheses indicates the year of last reapproval. A superscript epsilon ( $\epsilon$ ) indicates an editorial change since the last revision or reapproval.

*This standard has been approved for use by agencies of the U.S. Department of Defense.*

### 1. Scope\*

1.1 These test methods cover the determination of the maximum-index dry density/unit weight of cohesionless, free-draining soils using a vertically vibrating table. The adjective “dry before density or unit weight is omitted in the title and remaining portions of this standard to be consistent with the applicable definition given in Section 3 on Terminology.

#### 1.2 Systems of Units:

1.2.1 The testing apparatus described in this standard has been developed and manufactured using values in the gravimetric or inch-pound system. Therefore, test apparatus dimensions and mass given in inch-pound units are regarded as the standard.

1.2.2 It is common practice in the engineering profession to concurrently use pounds to represent both a unit of mass (lbm) and a unit of force (lbf). This implicitly combines two separate systems of units; that is, the absolute system and the gravitational system. It is scientifically undesirable to combine the use of two separate sets of inch-pound units within a single standard. This standard has been written using the gravitational system of units when dealing with the inch-pound system. In this system, the pound (lbf) represents a unit of force (weight). However, balances or scales measure mass; and weight must be calculated. In the inch-pound system, it is common to assume that 1 lbf is equal to 1 lbm. While reporting density is not regarded as nonconformance with this standard, unit weights should be calculated and reported since the results may be used to determine force or stress.

1.2.3 The terms density and unit weight are often used interchangeably. Density is mass per unit volume whereas unit weight is force per unit volume. In this standard density is given only in SI units. After the density has been determined, the unit weight is calculated in SI or inch-pound units, or both.

1.3 Four alternative methods are provided to determine the maximum index density/unit weight, as follows:

1.3.1 *Method 1A*—Using oven-dried soil and an electromagnetic, vertically vibrating table.

1.3.2 *Method 1B*—Using wet soil and an electromagnetic, vertically vibrating table.

1.3.3 *Method 2A*—Using oven-dried soil and an eccentric or cam-driven, vertically vibrating table. [/astm-d4253-16](https://www.astm.org/standards/D4253-16)

1.3.4 *Method 2B*—Using wet soil and an eccentric or cam-driven vertically vibrating table.

1.4 The method to be used should be specified by the individual assigning the test.

1.4.1 The type of table to be used (Method 1 or 2) is likely to be decided based upon available equipment.

NOTE 1—There is evidence to show that electromagnetic tables yield slightly higher values of maximum index density/unit weight than the eccentric or cam-driven tables.

1.4.2 It is recommended that both the dry and wet methods (Methods 1A and 1B or 2A and 2B) be performed when beginning a new job or encountering a change in soil types, as the wet method can yield significantly higher values of maximum index density/unit weight for some soils. Such a higher maximum index density, when considered along with the minimum index density/unit weight, Test Methods D4254, will be found to significantly affect the value of the relative density (3.2.8) calculated for a soil encountered in the field. While the dry method is often preferred because results can usually be obtained more quickly, as a general rule the wet method should be used if it is established that it produces maximum index densities/unit weights that would significantly affect the use/application of the value of relative density.

<sup>1</sup> This standard is under the jurisdiction of ASTM Committee D18 on Soil and Rock and are the direct responsibility of Subcommittee D18.03 on Texture, Plasticity and Density Characteristics of Soils.

Current edition approved Dec. 15, 2014 March 1, 2016. Published January 2015 March 2016. Originally approved in 1983. Last previous edition approved in 2006/2014 as D4253 – 00(2006) – 14. DOI: 10.1520/D4253-14.10.1520/D4253-16.

\*A Summary of Changes section appears at the end of this standard

1.5 These test methods are applicable to soils that may contain up to 15 %, by dry mass, of soil particles passing a No. 200 (75- $\mu\text{m}$ ) sieve, provided they still have cohesionless, free-draining characteristics (nominal sieve dimensions are in accordance with Specification E11). Further, these test methods are applicable to soils in which 100 %, by dry mass, of soil particles pass a 3-in. (75-mm) sieve.

1.5.1 Soils, for the purpose of these test methods, shall be regarded as naturally occurring cohesionless soils, processed particles, or composites or mixtures of natural soils, or mixtures of natural and processed particles, provided they are free draining.

1.6 These test methods will typically produce a higher maximum dry density/unit weight for cohesionless, free-draining soils than that obtained by impact compaction in which a well-defined moisture-density relationship is not apparent. However, for some soils containing between 5 and 15 % fines, the use of impact compaction (Test Methods D698 or D1557) may be useful in evaluating what is an appropriate maximum index density/unit weight.

1.7 These test methods will typically produce a lower maximum dry density/unit weight than that obtained by vibrating hammer using Test Method D7382.

1.8 For many types of free-draining, cohesionless soils, these test methods cause a moderate amount of degradation (particle breakdown) of the soil. When degradation occurs, typically there is an increase in the maximum index density/unit weight obtained, and comparable test results may not be obtained when different size molds are used to test a given soil.

1.9 All observed and calculated values shall conform to the guidelines for significant digits and rounding established in Practice D6026.

1.9.1 For purposes of comparing a measured or calculated value(s) to specified limits, the measured or calculated value(s) shall be rounded to the nearest decimal or significant digits in the specified limits.

1.9.2 The procedures used to specify how data are collected/recorded or calculated, in this standard are regarded as the industry standard. In addition, they are representative of the significant digits that generally should be retained. The procedures used do not consider material variation, purpose for obtaining the data, special purpose studies, or any considerations for the user's objectives; and it is common practice to increase or reduce significant digits of reported data to be commensurate with these considerations. It is beyond the scope of this standard to consider significant digits used in analysis methods for engineering design.

1.10 *This standard does not purport to address all of the safety concerns, if any, associated with its use. It is the responsibility of the user of this standard to establish appropriate safety and health practices and determine the applicability of regulatory limitations prior to use.*

## 2. Referenced Documents

### 2.1 ASTM Standards:<sup>2</sup>

C127 Test Method for Relative Density (Specific Gravity) and Absorption of Coarse Aggregate

D653 Terminology Relating to Soil, Rock, and Contained Fluids

D698 Test Methods for Laboratory Compaction Characteristics of Soil Using Standard Effort (12 400 ft-lbf/ft<sup>3</sup> (600 kN-m/m<sup>3</sup>))

D854 Test Methods for Specific Gravity of Soil Solids by Water Pycnometer

D1557 Test Methods for Laboratory Compaction Characteristics of Soil Using Modified Effort (56,000 ft-lbf/ft<sup>3</sup> (2,700 kN-m/m<sup>3</sup>))

D2216 Test Methods for Laboratory Determination of Water (Moisture) Content of Soil and Rock by Mass

D2487 Practice for Classification of Soils for Engineering Purposes (Unified Soil Classification System)

D2488 Practice for Description and Identification of Soils (Visual-Manual Procedure)

D3740 Practice for Minimum Requirements for Agencies Engaged in Testing and/or Inspection of Soil and Rock as Used in Engineering Design and Construction

D4254 Test Methods for Minimum Index Density and Unit Weight of Soils and Calculation of Relative Density

D4753 Guide for Evaluating, Selecting, and Specifying Balances and Standard Masses for Use in Soil, Rock, and Construction Materials Testing

D6026 Practice for Using Significant Digits in Geotechnical Data

D6913 Test Methods for Particle-Size Distribution (Gradation) of Soils Using Sieve Analysis

D7382 Test Methods for Determination of Maximum Dry Unit Weight and Water Content Range for Effective Compaction of Granular Soils Using a Vibrating Hammer

E11 Specification for Woven Wire Test Sieve Cloth and Test Sieves

E177 Practice for Use of the Terms Precision and Bias in ASTM Test Methods

E691 Practice for Conducting an Interlaboratory Study to Determine the Precision of a Test Method

<sup>2</sup> For referenced ASTM standards, visit the ASTM website, [www.astm.org](http://www.astm.org), or contact ASTM Customer Service at [service@astm.org](mailto:service@astm.org). For *Annual Book of ASTM Standards* volume information, refer to the standard's Document Summary page on the ASTM website.

### 3. Terminology

3.1 *Definitions*—For common definitions in this standard refer to Terminology **D653**.

3.2 *Definitions of Terms:*

3.2.1 *dry density/unit weight,  $\rho_d$  or  $\gamma_d$ ,  $n$* —the dry density/unit weight of a soil deposit or fill at the given void ratio.

3.2.2 *given void ratio,  $e$ ,  $n$* —the in situ or stated void ratio of a soil deposit or fill.

3.2.3 *maximum index density/unit weight,  $\rho_{dmax}$  or  $\gamma_{dmax}$ ,  $n$* —the reference dry density/unit weight of a soil in the densest state of compactness that can be attained using a standard laboratory compaction procedure that minimizes particle segregation and breakdown.

3.2.4 *maximum index void ratio,  $e_{max}$ ,  $n$* —the reference void ratio of a soil at the minimum index density/unit weight.

3.2.5 *minimum index density/unit weight,  $\rho_{dmin}$  or  $\gamma_{dmin}$ ,  $n$* —the reference dry density/unit weight of a soil in the loosest state of compactness at which it can be placed using a standard laboratory procedure, which prevents bulking and minimizes particle segregation.

3.2.6 *minimum index void ratio,  $e_{min}$ ,  $n$* —the reference void ratio of a soil at the maximum index density/unit weight.

3.2.7 *relative density,  $D_d$ ,  $n$* —the ratio, expressed as a percentage, of the difference between the maximum index void ratio and any given void ratio of a cohesionless, free-draining soil; to the difference between its maximum and minimum index void ratios.

3.2.7.1 *Discussion*—

The equation for relative density is as follows:

$$D_d = \frac{e_{max} - e}{e_{max} - e_{min}} \times 100 \quad (1)$$

or, in terms of corresponding dry densities

$$D_d = \frac{\rho_{dmax} (\rho_d - \rho_{dmin})}{\rho_d (\rho_{dmax} - \rho_{dmin})} \times 100 \quad (2)$$

in terms of corresponding or dry unit weights

$$D_d = \frac{\gamma_{dmax} (\gamma_d - \gamma_{dmin})}{\gamma_d (\gamma_{dmax} - \gamma_{dmin})} \quad (3)$$

3.2.8 *percent compaction or relative compaction,  $R_c$ ,  $n$* —the ratio, expressed as a percentage, of the dry density/unit weight of a given soil to its maximum index density/unit weight.

<https://standards.iteh.ai/catalog/standards/sist/fba3bf83-f1ca-46ee-917f-0fb7977f075d/astm-d4253-16>

3.2.8.1 *Discussion*—

The equation for percent compaction or relative compaction is:

$$R_c = \frac{\rho_d}{\rho_{dmax}} \times 100 \quad (4)$$

or

$$R_c = \frac{\gamma_d}{\gamma_{dmax}} \times 100 \quad (5)$$

3.2.9 *density index,  $I_d$* —the ratio, expressed as a percentage, of the difference between any given dry density/unit weight and the minimum index density/unit weight of a given cohesionless soil to the difference between its maximum and minimum index densities/unit weights.

3.2.9.1 *Discussion*—

The equation for density index is:

$$I_d = \frac{\rho_d - \rho_{dmin}}{\rho_{dmax} - \rho_{dmin}} \times 100 \quad (6)$$

or

$$I_d = \frac{\gamma_d - \gamma_{dmin}}{\gamma_{dmax} - \gamma_{dmin}} \quad (7)$$

#### 4. Summary of Test Method

4.1 The maximum index density/unit weight of a given free-draining soil is determined by placing either oven-dried or wet soil in a mold, applying a 2-lb/in.<sup>2</sup> (14-kPa) surcharge (dead weight) to the surface of the soil, and then vertically vibrating the mold, soil, and surcharge. Use either an electromagnetic, eccentric, or cam-driven vibrating table having a sinusoid-like time-vertical displacement relationship at a double amplitude of vertical vibration (peak-to-peak) of about  $0.013 \pm 0.002$  in. ( $0.33 \pm 0.05$  mm) at a frequency of 60 Hz for  $8.00 \pm 0.25$  minutes or  $0.019 \pm 0.003$  in. ( $0.48 \pm 0.08$  mm) at 50 Hz for  $10.00 \pm 0.25$  minutes. The maximum index density/unit weight is calculated by dividing the oven-dried mass of the densified soil by its volume (average height of densified soil times area of mold).

#### 5. Significance and Use

5.1 For many cohesionless, free-draining soils, the maximum index density/unit weight is one of the key components in evaluating the state of compactness of a given soil mass that is either naturally occurring or placed during construction.

5.1.1 Relative density and percent compaction are commonly used for evaluating the state of compactness of a given soil mass. Density/unit weight index is also sometimes used. See Section 3 for descriptions of terms.

5.2 It is generally recognized that either relative density or percent compaction is a good indicator of the state of compactness of a given soil mass. However, the engineering properties, such as strength, compressibility, and permeability of a given soil, compacted by various methods to a given state of compactness can vary considerably. Therefore, considerable engineering judgment must be used in relating the engineering properties of soil to the state of compactness.

5.3 An absolute maximum density/unit weight is not necessarily obtained by these test methods.

NOTE 2—In addition, there are published data to indicate that these test methods have a high degree of variability.<sup>3</sup> However, the variability can be greatly reduced by careful calibration of equipment, including the vibrating table, and careful attention to proper test procedure and technique.

NOTE 3—The quality of the result produced by this standard is dependent on the competence of the personnel performing it, and the suitability of the equipment and facilities used. Agencies that meet the criteria of Practice D3740, generally, are considered capable of competent and objective testing/sampling/inspection/etc. Users of this standard are cautioned that compliance with Practice D3740 does not in itself ensure reliable results. Reliable results depend on many factors; Practice D3740 provides a means of evaluating some of those factors.

5.4 The double amplitude of vertical vibration has been found to have a significant effect on the density obtained.<sup>3</sup> For a particular vibrating table and mold assembly, the maximum index density/unit weight of a given material may be obtained at a double amplitude of vibration other than the double amplitude of  $0.013 \pm 0.002$  in. ( $0.33 \pm 0.05$  mm) at a frequency of 60 Hz or  $0.019 \pm 0.003$  in. ( $0.48 \pm 0.08$  mm) at 50 Hz required in this method; that is, dry density/unit weight may initially increase with increasing double amplitude of vibration, reach a peak, and then decrease with further increases in double amplitude of vibration. Furthermore, the relationship between the peak density/unit weight and optimum double amplitude of vibration (double amplitude of vibration where peak density/unit weight occurs) can vary with various soil types and gradations.

5.5 The use of the standard molds (6.1.1) has been found to be satisfactory for most soils requiring maximum index-density/unit weight testing. Special molds (6.1.2) shall only be used when the test results are to be applied in conjunction with design or special studies and there is not enough soil to use the standard molds. Such test results should be applied with caution as maximum index densities/unit weights obtained with the special molds may not agree with those that would be obtained using the standard molds.

#### 6. Apparatus

6.1 *Mold Assembly*—An example of a typical mold assembly is shown in Fig. 1. Individual components and accessories shall be as follows:

6.1.1 *Standard Molds*—~~Cylindrical metal molds having nominal volumes~~ Two cylindrical metal molds, one having a nominal volume of 0.100 ft<sup>3</sup> (2830 cm<sup>3</sup>) and one having a nominal volume of 0.500 ft<sup>3</sup> (14 200 cm<sup>3</sup>), conforming to the design methodology presented in Fig. 2. The molds shall conform to the requirements shown in the table in Fig. 2. The actual volume of the molds shall be within  $\pm 1.5\%$  of the specified nominal volume.

6.1.2 *Special Molds*—Cylindrical metal molds having a capacity less than 0.100 ft<sup>3</sup> (2830 cm<sup>3</sup>), an inside diameter equal to or greater than 2.75 in. (70 mm), but less than 4 in. (100 mm) and conforming to the design methodology presented in Fig. 3. Such molds may only be used when the test results are to be used in conjunction with design or other special studies or both, and there is not enough soil to use the 0.100 ft<sup>3</sup> (2830 cm<sup>3</sup>) mold.

6.1.3 *Guide Sleeves*—One guide sleeve with clamp assembly, or other suitable attachment devices [see Fig. 4(a)], for each size mold. For easy centering of the guide sleeve above the mold, two of the three setscrews on the clamp assembly should be provided with lock nuts.

6.1.4 *Surcharge Base Plates*—One surcharge base plate for each standard size mold, conforming to the requirements of Fig. 5.

6.1.5 *Surcharge Weights*—One surcharge weight for each size mold. See Fig. 5 for tolerances related to the 0.100 ft<sup>3</sup> (2830 cm<sup>3</sup>) and 0.500 ft<sup>3</sup> (14 200 cm<sup>3</sup>) molds. For special molds, similar tolerances should be maintained. The total mass of the surcharge base

<sup>3</sup> E. T. Selig and R. S. Ladd, eds., *Evaluation of Relative Density and its Role in Geotechnical Projects Involving Cohesionless Soils*, ASTM STP 523, ASTM, 1973.

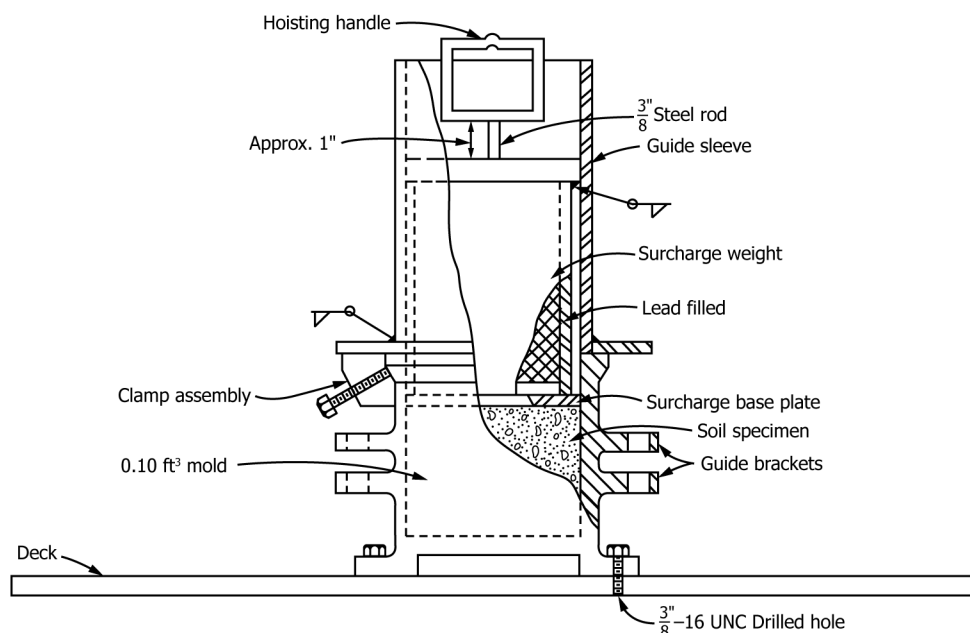

FIG. 1 Schematic Drawing of a Typical Mold Assembly

plate and surcharge weight shall be equivalent to a surcharge stress of  $2.00 \pm 0.02 \text{ lb/in.}^2$  ( $13.8 \pm 0.1 \text{ kPa}$ ) for the mold being used. For special molds, the surcharge base plate and weight can be composed of a single solid mass of metal.

6.1.6 *Surcharge Base-Plate Handle*—A device used to initially place and then to remove the surcharge base plate upon completion of densification. An example of such a handle is given in Fig. 4(b); however, any convenient hooking device may be used.

6.2 *Dial-Indicator Gauge Holder and Dial Indicator*—A device used, in conjunction with the guide brackets, to measure the difference in elevation between the top surfaces of the mold and surcharge base plate after densification [Fig. 4(c)]. The dial indicator shall have a 2-in. (50-mm) or greater travel, with 0.001-in. (0.025-mm) graduations and mounted so that the dial stem is parallel with the vertical axis of the mold. The dial indicator may be digital, analog clockwise-movement type where the dial pointer reads zero when the stem is extended, or counterclockwise type where the dial pointer reads zero when the stem is all the way in.

6.3 *Balance(s)*, of sufficient capacity to determine the total mass of the specimen and mold, having sufficient accuracy that the mass of the soil is determined to the nearest 0.1 %. Examples of balances capable of satisfying these requirements for most conditions have specifications as follows:

6.3.1 For 0.500-ft<sup>3</sup> (14 200-cm<sup>3</sup>) molds, use a balance having a minimum capacity of 40-kg and meeting the requirements of Specification D4753 for Class GP 10 (readability of 5 g).

6.3.2 For 0.100-ft<sup>3</sup> (2830-cm<sup>3</sup>) molds, use a balance of at least 15-kg capacity and meeting the requirements of Specification D4753 for Class GP 5 (readability of 1 g).

6.3.3 For special molds that are less than 0.1-ft<sup>3</sup> (2830-cm<sup>3</sup>), use a balance having a minimum capacity of at least 2-kg and meeting the requirements of Specification D4753 for a Class GP 2 (readability of 0.1 g).

6.4 *Hoist*—A rope, chain, or cable hoist of at least 140-kg capacity when either the 0.100-ft<sup>3</sup> (2830-cm<sup>3</sup>) or 0.500-ft<sup>3</sup> (14 200 cm<sup>3</sup>) size molds are being used.

6.5 *Drying Oven*, thermostatically controlled, preferably of the forced-draft type, capable of maintaining a uniform temperature of  $110 \pm 5^\circ\text{C}$  throughout the drying chamber.

6.6 *Sieves*, 3-in. (75-mm), 1½-in. (37.5-mm), ¾-in. (19-mm), ⅜-in. (9.5-mm), No. 4 (4.75-mm), and No. 200 (75-µm) sieves conforming to the requirements of Specifications E11.

6.7 *Calibration Bar*, metal, about 3 by 12 by ¼ in. (75 by 300 by 6 mm), optional (see 10.4).

6.8 Other equipment such as mixing pans, a large metal scoop, a hair-bristled dusting brush, a timing device indicating minutes and seconds, and a micrometer with at least a 1-in. (25-mm) travel and with 0.001-in. (0.025-mm) graduations.

6.9 *Vibrating Table*, shall be mounted to a concrete floor or mass of sufficient size and configuration that excess vibrations are not transmitted to other testing areas. The vertically vibrating deck of the table shall be of sufficient size and rigidity that the mold assembly being used can be attached and rigidly supported during the test. The table shall be capable of vertically vibrating the



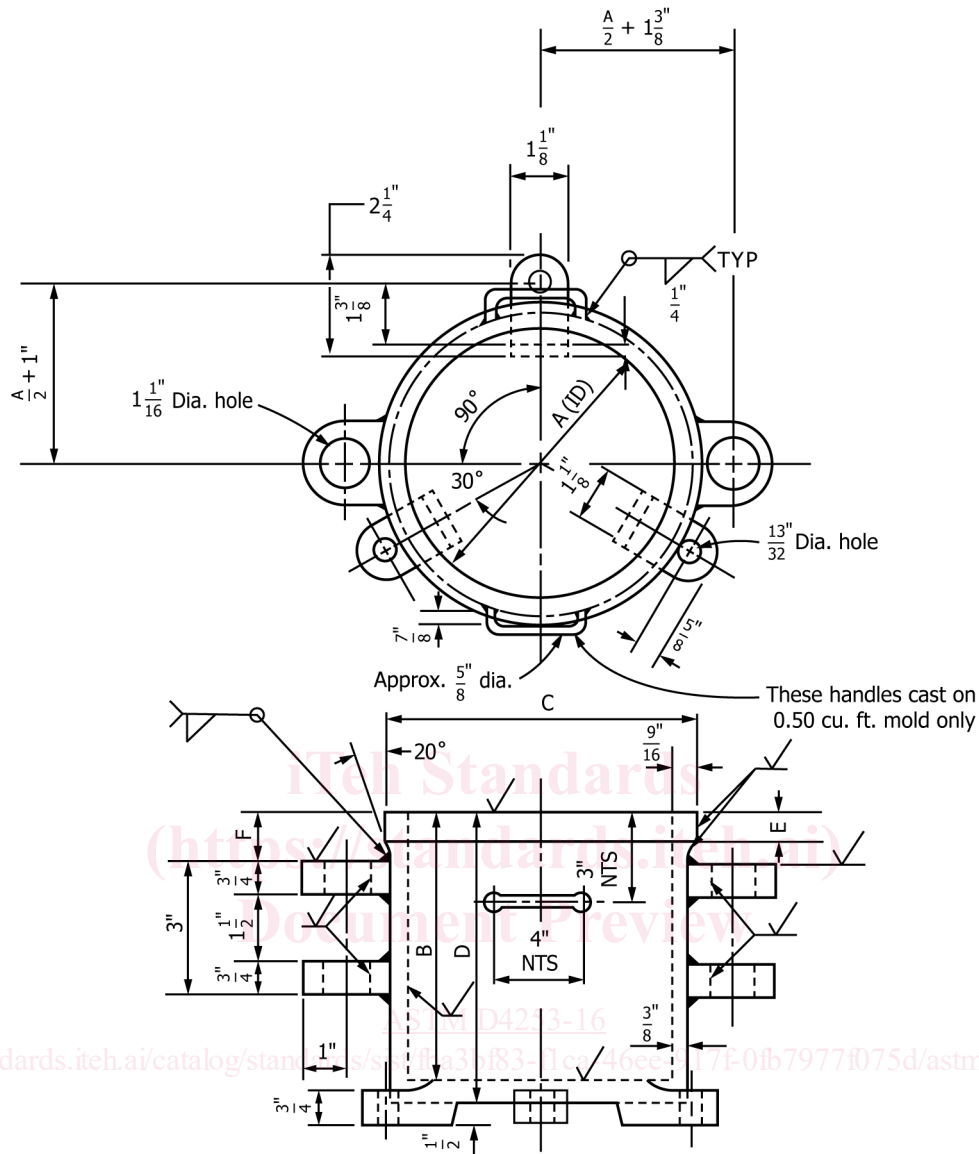

<https://standards.iteh.ai/catalog/standards/sist/fba3bf83-11ca-46cc-817f-0fb7977f075d/astm-d4253-16>

Size Mold ft <sup>3</sup> (cm <sup>3</sup> )	Dimensions, in. (mm)					
	A	B	C	D	E	F
Tolerances	+0.005, -0.000 (+0.13, -0.00)	+0.005, -0.000 (+0.13, -0.00)	±0.016 (±0.4)	±0.016 (±0.4)	±0.016 (±0.4)	±0.016 (±0.4)
0.100 (2830)	6.000 (152.40)	6.112 (155.24)	7.13 (181.1)	6.50 (165.1)	0.50 (12.7)	1.13 (28.7)
0.500 (14 200)	11.000 (279.40)	9.092 (230.94)	12.13 (308.0)	9.50 (241.3)	0.63 (16.0)	2.00 (50.8)

FIG. 2 Details of Molds

mold assembly with a sinusoidal time-vertical displacement relationship at an average double amplitude (peak-to-peak displacement) of  $0.013 \pm 0.002$  in. ( $0.33 \pm 0.05$  mm) at a frequency of 60 Hz or  $0.019 \pm 0.003$  in. ( $0.48 \pm 0.08$  mm) at 50 Hz under test conditions. The table shall have the capability for adjustment of the frequency of vibration (between 0 to 60 Hz) or double amplitude of vibration, or both, between about 0.005 in. (0.15 mm) and 0.013 in. (0.33 mm) at 60 Hz or about 0.007 in. (0.20 mm) and 0.019 in. (0.48 mm) at 50 Hz for use with Methods 1A, 1B, 2A, or 2B (11.2.3).

6.9.1 Use one of the following table types:

6.9.1.1 *Electromagnetic Vibrating Table*—A steel table conforming to the requirements of 6.9 with a vertically vibrating, cushioned steel deck generally 30 by 30 in. (760 by 760 mm), actuated by an electromagnetic vibrator of the solid-impact type with a net mass over 45 kg. The table shall be mounted to a concrete floor or slab having a mass of greater than 450 kg.