



Standard Test Method for Room Fire Test of Wall and Ceiling Materials and Assemblies¹

This standard is issued under the fixed designation E2257; the number immediately following the designation indicates the year of original adoption or, in the case of revision, the year of last revision. A number in parentheses indicates the year of last reapproval. A superscript epsilon (ϵ) indicates an editorial change since the last revision or reapproval.

1. Scope

1.1 This is a fire-test-response standard.

1.2 This test method is intended to evaluate, under specified fire-exposure conditions, the contribution to room fire growth provided by wall or ceiling materials and assemblies, or both. The method is not intended to evaluate the fire endurance of assemblies or fires originating in the wall assembly. The method provides a means to evaluate the effectiveness of thermal barriers in restricting the contribution of combustible materials in the wall assembly to fire growth in a room fire.

1.3 This test method, simulating a fire in the corner of a 2420 by 3630 mm (8 by 12 ft) room containing a single open doorway, provides a means to evaluate the relative performance of specified wall and ceiling materials or assemblies when they are used together in the same relationship within an enclosure, and simulating the manner in which they will be used.

1.4 This test method is intended to evaluate the contribution to fire growth provided by a surface product using a specified ignition source. It shall, however, be noted that the type, position and heat output of the ignition source will considerably influence fire growth. The thermal exposure conditions from the ignition source specified in this method will result in flashover during the 20 min duration for many common finish materials, in particular if specimens are mounted on the walls and the ceiling (standard configuration).

1.5 This test method provides a means for evaluating wall and ceiling finish materials and assemblies, including panels, tiles, boards, sprayed or brushed coatings, etc. This test method is not intended to evaluate flooring materials or furnishings.

1.6 This method shall be used in conjunction with Guide E603, which covers instrumentation and the general effect of various parameters, and Guide E2067, which deals with full-scale oxygen consumption calorimetry.

1.7 The values stated in SI units are to be regarded as the standard. The units given in parentheses are for information only.

1.8 The text of this standard references notes and footnotes which provide explanatory information. These notes and footnotes (excluding those in figures) shall not be considered as requirements of the standard.

1.9 This standard is used to measure and describe the response of materials, products, or assemblies to heat and flame under controlled conditions, but does not by itself incorporate all factors required for fire-hazard or fire-risk assessment of the materials, products, or assemblies under actual fire conditions.

1.10 *This standard does not purport to address all of the safety concerns, if any, associated with its use. It is the responsibility of the user of this standard to establish appropriate safety and health practices and determine the applicability of regulatory limitations prior to use.*

1.11 *Fire testing is inherently hazardous. Adequate safeguards for personnel and property shall be employed in conducting these tests.*

2. Referenced Documents

2.1 *ASTM Standards:*²

[E84 Test Method for Surface Burning Characteristics of Building Materials](#)

[E136 Test Method for Behavior of Materials in a Vertical Tube Furnace at 750°C](#)

¹ This test method is under the jurisdiction of ASTM Committee E05 on Fire Standards and is the direct responsibility of Subcommittee E05.21 on Smoke and Combustion Products.

Current edition approved Aug. 1, 2013; Feb. 1, 2016. Published September 2013; March 2016. Originally approved in 2003. Last previous edition approved in 2013 as E2257-13-13a. DOI: 10.1520/E2257-13A-10.1520/E2257-16.

² For referenced ASTM standards, visit the ASTM website, www.astm.org, or contact ASTM Customer Service at service@astm.org. For *Annual Book of ASTM Standards* volume information, refer to the standard's Document Summary page on the ASTM website.

[E176 Terminology of Fire Standards](#)

[E603 Guide for Room Fire Experiments](#)

[E2067 Practice for Full-Scale Oxygen Consumption Calorimetry Fire Tests](#)

2.2 *ISO Standards:*

[ISO 9705 Fire Tests—Reaction to Fire—Room Fire Test](#)³

[ISO 13943 Fire Safety—Vocabulary](#)³

2.3 *NFPA Standards:*

[NFPA 265 Standard Method of Tests for Evaluating Room Fire Growth Contribution of Textile Wall Coverings](#)⁴

[NFPA 286 Standard Method of Tests for Evaluating Contribution of Wall and Ceiling Interior Finish to Room Fire Growth](#)⁴

3. Terminology

3.1 *Definitions*—For definitions of terms used in this standard, see Terminology [E176](#) and ISO 13943. In case of conflict, the definitions given in Terminology [E176](#) shall prevail.

3.1.1 *assembly, n*—a unit or structure composed of a combination of materials or products, or both. **E176**

3.1.2 *flashover, n*—the rapid transition to a state of total surface involvement in a fire of combustible materials within an enclosure. **E176**

3.1.3 *heat flux, n*—heat transfer to a surface per unit area, per unit time. **E176**

3.1.4 *heat release rate, n*—the heat evolved from the specimen per unit time. **E176**

3.1.5 *optical density of smoke, n*—a measure of the attenuation of a light beam through smoke, expressed as the common logarithm of the ratio of the incident flux, I_0 , to the transmitted flux, I . **E176**

3.1.6 *oxygen consumption principle, n*—the expression of the relationship between the mass of oxygen consumed during combustion and the heat released. **E176**

3.1.7 *smoke, n*—the airborne solid and liquid particulates and gases evolved when a material undergoes pyrolysis or combustion. **E176**

3.1.8 *smoke obscuration, n*—reduction of light transmission by smoke as measured by light attenuation. **E176**

3.2 *Definitions of Terms Specific to This Standard:*

3.2.1 *specimen, n*—representative piece of the product, which is to be tested together with any substrate or treatment.

4. Summary of Test Method

4.1 This method uses a gas burner to produce a diffusion flame in contact with the walls and ceiling in the corner of a 2420 by 3630 by 2420 mm (8 by 12 by 8 ft) high room. The burner produces a prescribed net rate of heat output of 100 kW (5690 Btu/min) during the first 10 min, followed by 300 kW (17 060 Btu/min) during the next 10 min. The contribution of the wall and ceiling materials or assemblies to fire growth is measured in terms of the time history of the incident heat flux on the center of the floor, the time history of the temperature of the gases in the upper part of the room, the time to flashover, and the rate of heat release. The test is conducted with natural ventilation to the room provided through a single doorway 780 by 2015 mm (30 by 80 in.) in width and height. The combustion products are collected in a hood feeding into a plenum connected to an exhaust duct in which measurements are made of the gas velocity, temperature, light obscuration, and concentrations of oxygen, carbon dioxide, and carbon monoxide.

5. Significance and Use

5.1 This fire test is applicable to a description of certain fire performance characteristics in appraising wall and ceiling materials, products, or systems under specified fire-exposure conditions in an enclosure. The test indicates the maximum extent of fire growth in a room, the rate of heat release, and if they occur, the time to flashover, and the time to flame extension beyond the doorway following flashover. It determines the extent to which the wall and ceiling materials or assemblies contribute to fire growth in a room and the potential for fire spread beyond the room, under the particular conditions simulated. It does not measure the contribution of the room contents. (See [Appendix X1](#), Commentary.)

NOTE 1—Time to flashover is defined herein as either the time when the radiant flux onto the floor exceeds 20 kW/m² or the average temperature of the upper hot gas layer reaches 600°C (1100°F) or flames exit the doorway or spontaneous ignition of a paper target on the floor occurs. The spontaneous ignition of a crumpled single sheet of newspaper placed on the floor 0.9 m (3 ft) out from the center of the rear wall provides a visual indication of flashover.

5.1.1 The potential for the spread of fire to other objects in the room, remote from the ignition source, is evaluated by measurements of: (a) the total heat flux incident on the center of the floor, and (b) a characteristic upper level gas temperature in the room.

³ Available from International Organization for Standardization (ISO), 1 rue de Varembé, Case postale 56, CH-1211, Geneva 20, Switzerland.

⁴ Available from National Fire Protection Association (NFPA), 1 Batterymarch Park, Quincy, MA 02269-9101.

5.1.2 The potential for the spread of fire to objects outside the room of origin is evaluated by the measurement of the rate of heat release of the fire.

5.1.3 Measurements of the rate of production of carbon monoxide, carbon dioxide, and visible smoke are taken.

5.1.4 The overall performance of the test specimen is visually documented by full-color photographic records. Video taping of the complete fire test is an acceptable alternative to the photographic record. Such records show when each area of the test specimen becomes involved in the fire.

5.2 Flashover shall be considered to have occurred when any two of the following conditions have been attained:

- (a) Heat release rate exceeds 1 MW.
- (b) Heat flux at the floor exceeds 20 kW/m².
- (c) Average upper layer temperature exceeds 600°C.
- (d) Flames exit doorway.
- (e) A paper target on the floor auto-ignites.

5.2.1 Time to flashover shall be the time from start of test until the second condition has been attained.

5.3 The potential for the spread of fire to other objects in the room, remote from the ignition source, is evaluated by measurements of: (a) the total heat flux incident on the center of the floor, and (b) a characteristic upper level gas temperature in the room.

5.4 The potential for the spread of fire to objects outside the room of origin is evaluated by the measurement of the rate of heat release of the fire.

5.5 Measurements of the rate of production of carbon monoxide, carbon dioxide, and visible smoke are taken.

5.6 The overall performance of the test specimen is visually documented by full-color photographic records. Video taping of the complete fire test is an acceptable alternative to the photographic record. Such records show when each area of the test specimen becomes involved in the fire.

5.7 In this procedure, the specimens are subjected to a specific set of laboratory fire test exposure conditions. If different test conditions are substituted or the anticipated end-use conditions are changed, it is not known whether it is possible by use of this test to predict changes in the performance characteristics measured. Therefore, the results are strictly valid only for the fire test exposure conditions described in this procedure.

6. Ignition Source

6.1 The ignition source for the test shall be a gas burner with a nominal 170 by 170 mm (6.7 by 6.7 in.) porous top surface of a refractory material, as shown in Fig. 1.

6.2 The top surface of the burner through which the gas is supplied shall be located horizontally, 170 mm (6.7 in.) off the floor, and the burner enclosure shall be in contact with both walls in a corner of the room opposite from the door, and the edge of the diffusion surface shall be flush with the wall.

6.3 The burner shall be supplied with C.P. grade propane (99 % purity), with a net heat of combustion of 46.5 ± 0.5 MJ/kg (20 000 ± 200 Btu/lb.) The gas flow to the burner shall be measured with an accuracy of at least ±3 %. The flow measuring equipment shall be calibrated per the manufacturer's instructions at least once per year. The heat output to the burner shall be controlled within ±5 % of the prescribed value.

6.4 The gas supply to the burner shall produce a net heat output of 100 ± 3 kW (5690 ± 170 Btu/min) for the first 10 min, followed by 300 ± 10 kW (17060 ± 570 Btu/min) for the next 10 min.

NOTE 1—This corresponds to a flow of approximately 67.3 L/min at 100 kW, and 202.0 L/min at 300 kW for propane with a net heat of combustion of 46.5 MJ/kg, under standard conditions of 101 kPa pressure and 20°C temperature.

6.5 The burner shall be ignited by a pilot burner or a remotely controlled spark igniter.

6.6 Burner controls shall be provided for automatic gas supply shut-off if flameout occurs.

7. Compartment Geometry and Construction

NOTE 2—The choices for the size of compartment fire experiments are discussed in Guide E603. The compartment dimensions and tolerances defined in this section have been chosen to make it convenient to utilize both standard U.S. size 1.22 by 2.44 m (4 by 8 ft) building materials or panels and standard 1.2 by 2.4 m panel sizes common outside the U.S.

7.1 The room shall consist of four walls at right angles, floor, and ceiling and shall have the following inner dimensions: 3630 ± 30 mm (12 ft) in length, 2420 ± 20 mm (8 ft) in width, and 2420 ± 20 mm (8 ft) in height (see Fig. 2). The room shall be placed indoors in an essentially draft free, conditioned space, large enough to ensure that there is no influence on the test fire. In order to facilitate the mounting of the instruments and of the ignition source, it is convenient to place the test room so that the floor is accessible from beneath.

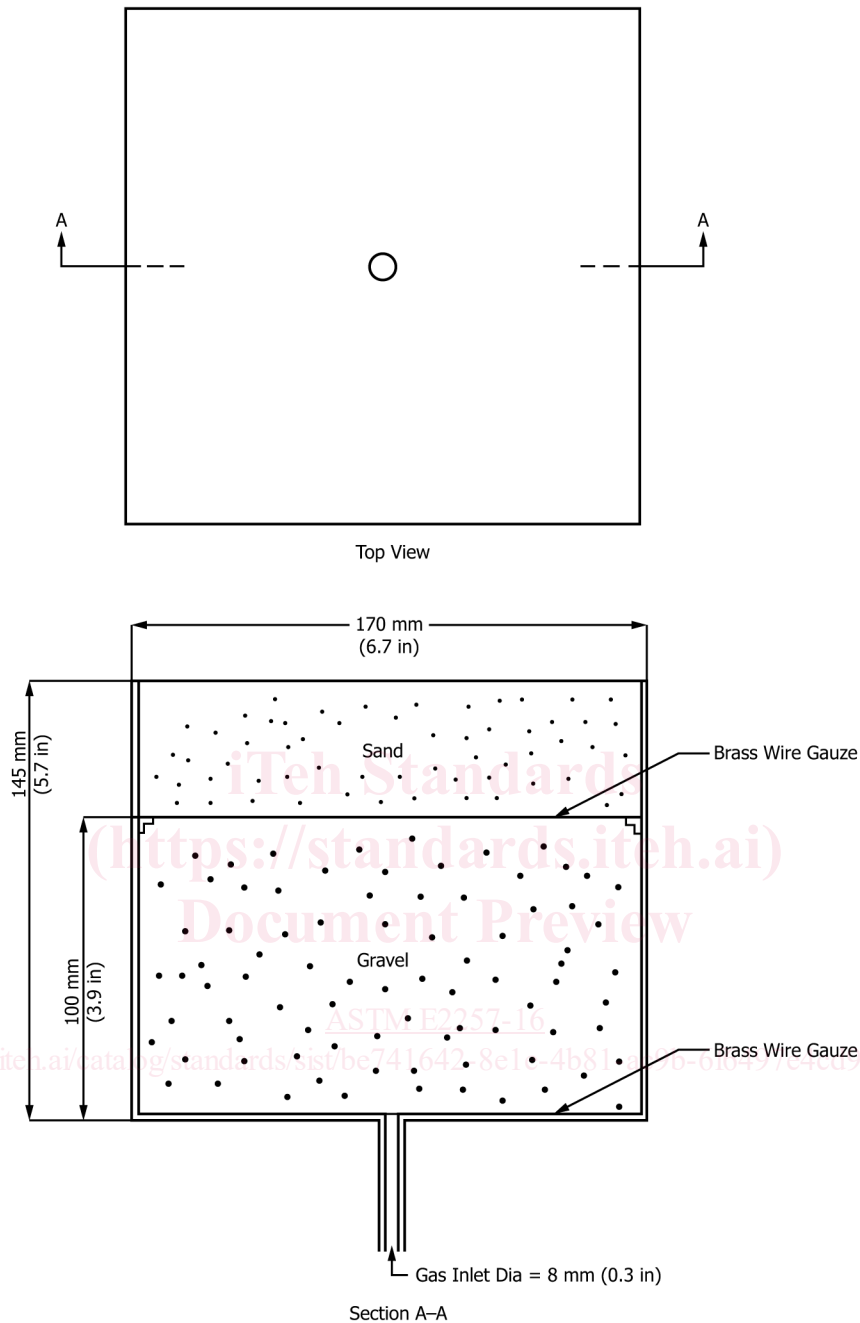

Particle size:	Sand	2 – 3 mm (0.08 – 0.12 in)
	Gravel	4 – 8 mm (0.16 – 0.31 in)
Wire Gauze:	Top	1.4 mm (0.055 in)
	Bottom	2.8 mm (0.11 in.)

FIG. 1 Gas Burner Ignition Source

7.2 There shall be a doorway in the center of one of the 2420 by 2420 mm (8 by 8 ft) walls, and no other wall, floor or ceiling openings that allow ventilation. The doorway shall have the following dimensions: 780 ± 20 mm (30 in.) in width, and 2015 ± 15 mm (80 in.) in height.

7.3 The test compartment shall be a framed or a concrete-block structure. If the former type of structure is used, the interior walls and ceiling of the frame shall be lined with gypsum wallboard or calcium silicate board with a density of 500 to 800 kg/m³ (31 to 50 lb/ft³). The minimum thickness of the lining material shall be 20 mm (¾ in.).

7.4 If self-supporting panels are tested, a separate exterior frame or block compartment is not required.

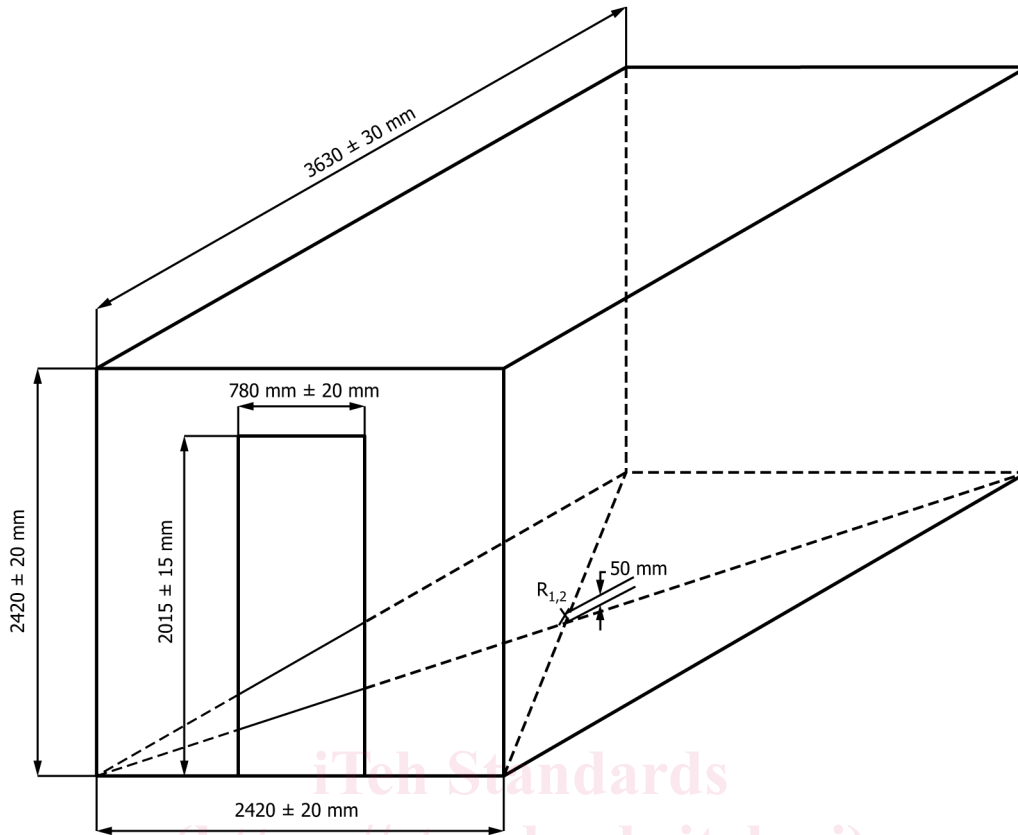

FIG. 2 Room Geometry and Placement of Heat Flux Meter

8. Instrumentation in the Fire Room

8.1 The following are minimum requirements for instrumentation for this test. Added instrumentation is desirable for further information.

8.2 Heat Flux:

8.2.1 *Specification*—The total heat flux meters shall be of the Gardon (foil) or the Schmidt-Boelter (thermopile) type with a design range of approximately 50 kW/m^2 ($4.4 \text{ Btu/ft}^2\text{s}$). The target receiving radiation, and possibly to a small extent convection, shall be flat, circular, not more than 15 mm ($5/8 \text{ in.}$) in diameter and coated with a durable matt black finish. The target shall be contained within a water-cooled body whose front face shall be of highly polished metal, flat, coinciding with the plane of the target and circular, with a diameter of not more than 50 mm (2 in.). The heat flux meter shall have an accuracy of at least $\pm 3 \%$ and a repeatability within $\pm 0.5 \%$. In operation, the meter shall be maintained at a constant temperature, at least 5°C above the dew point.

8.2.2 *Location*—The heat flux meter shall be mounted at the geometric center of the floor (see Fig. 2). The target area shall be between 5 and 30 mm ($1/4$ and $1 1/4 \text{ in.}$) above the floor surface.

8.2.3 *Calibration*—The heat flux meters shall be calibrated at yearly intervals.

8.3 Gas Temperatures:

8.3.1 *Specification*—Bare Type K Chromel-Alumel thermocouples 0.5 mm (20 mil) in diameter shall be used at each required location. The thermocouple wire, within 13 mm ($1/2 \text{ in.}$) of the bead, shall be run along expected isotherms (horizontally) to minimize conduction errors. The insulation between the Chromel and Alumel wires shall be stable to at least 1100°C (2000°F), or the wires shall be separated.

NOTE 3— 1.6 mm OD Inconel sheathed thermocouples with an ungrounded junction and high purity (99.4%) magnesium oxide insulation will work satisfactorily. The commonly used silicone-impregnated glass insulation breaks down above 800°C (1500°F).

8.3.2 *Location in Doorway*—A thermocouple shall be located in the interior plane of the door opening on the door centerline, 100 mm (4 in.) down from the top (see Fig. 3).

8.3.3 *Locations for Room*—Thermocouples shall be located 100 mm (4 in.) down from the center of the ceiling and from the center of each of the four ceiling quadrants, and one shall be directly over the center of the ignition burner, 100 mm (4 in.) below the ceiling. The thermocouples shall be mounted on supports or penetrate through the ceiling with their junctions at least 100 mm

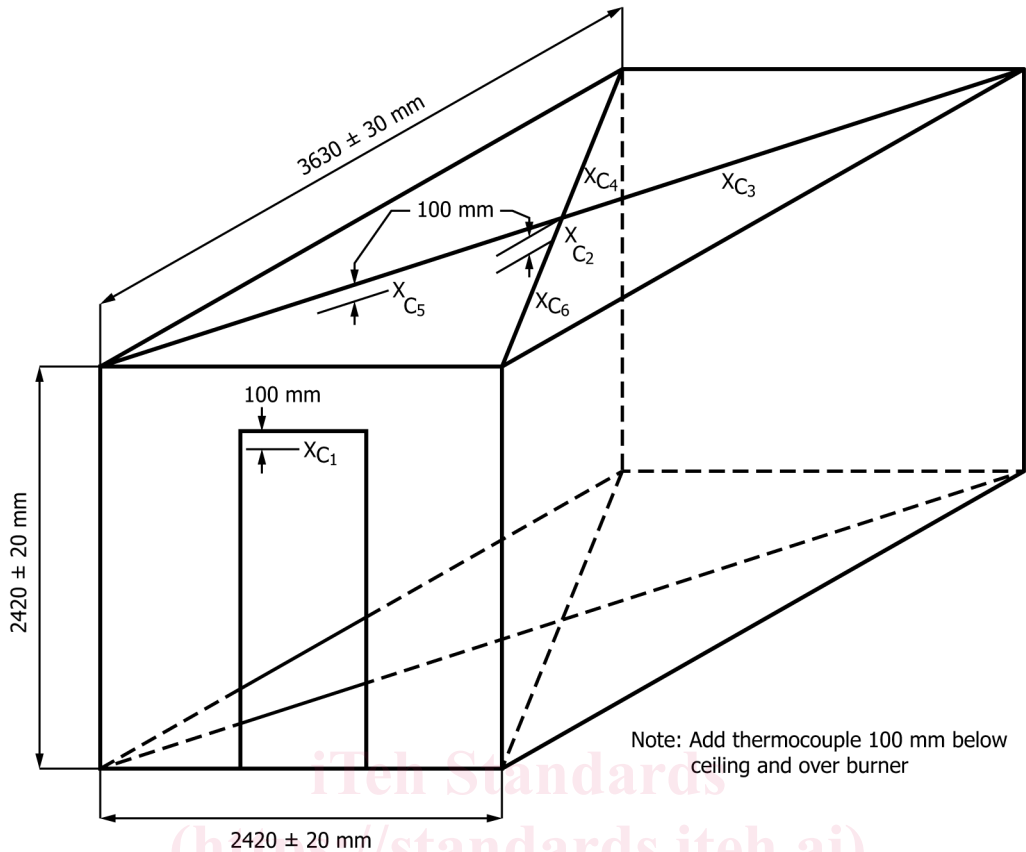

FIG. 3 Room Geometry and Thermocouple Placement

(4 in.) away from a solid surface. There shall be no attachments to the test specimens. Any ceiling penetration shall be just large enough to permit passage of the thermocouples with back filling using spackling compound or ceramic fiber insulation.

8.4 Photographic and Video Records:

8.4.1 *Specification*—Photographic and video equipment shall be used to record continuously the fire spread in the room and the fire projection from the door of the room. The location of the camera shall avoid interference with the air inflow.

8.4.2 When wall linings are tested, the interior wall surfaces of the test room, adjacent to the corner in which the burner is located, shall be clearly marked with a 0.3 m (12 in.) grid. A clock shall appear in all photographic and video records, giving time to the nearest 1 s or 0.01 min from the start of the test. This clock shall be accurately synchronized with all other measurements, or other provisions shall be made to correlate the photo record with time.

8.4.3 *Location and Level of Lighting*—A 300-Watt flood-type quartz halogen lamp shall be positioned diametrically opposite the ignition source near floor level. The lamp shall be aimed at the wall corner/ceiling intersection above the ignition source.

8.4.4 *Photographic Records*—If 35 mm color photographs are used, they shall be taken at 15 s intervals for the first 3 min of the test and at least at 60 s intervals thereafter for the duration of the test.

8.4.5 *Type and Location of Video Camera*—A video camera with a manually adjustable iris, adjusted to prevent automatic closing of the iris opening due to brightness of the fire (at least 50 % open) shall be used. A video monitor shall be used to determine when adjustments and compensation for the brightness of the ignition flames are needed.

8.4.5.1 The video camera mount shall be adjusted so that the camera lens is approximately 900 mm (3 ft) from the floor. The camera angle and magnification shall be adjusted until the top of the doorway and the top of the burner are visible and the ceiling area directly above the fire is in full view.

8.4.5.2 A timer depicting “elapsed time” shall be included in all videos. The timer shall be permitted to be integral to the video camera. The timer shall be clearly viewed throughout the test period.

8.4.5.3 Prior to ignition of the burner, the date and laboratory test report identification number shall be filmed. The video shall be started at least 30 s prior to ignition of the burner, and the video recording shall be continuous for the duration of the test period.

8.4.6 Flood lights shall not raise the ambient temperature in the room above that specified in Section 12.

NOTE 4—A window, cut 600 mm (2 ft) above the floor in the front wall facing the gas burner, fitted with heat-resistant, impact-resistant glazing, provides useful photographic access.

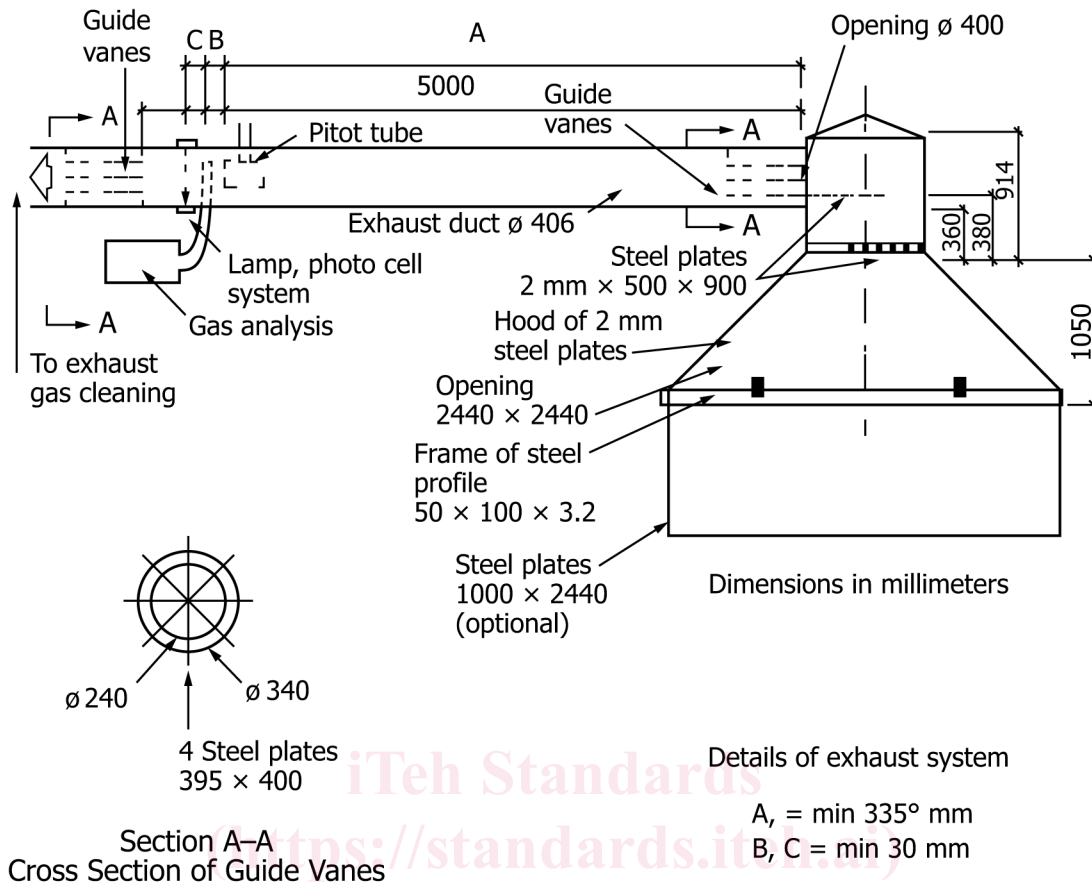

FIG. 4 Hood Geometry and Placement of Duct Instrumentation

8.5 Place a crumpled sheet of newspaper on the floor 0.9 m out from the center of the rear wall to be used as the paper target to assess time to flashover, in accordance with 5.2.

9. Canopy Hood and Exhaust Duct

9.1 *Location and Design*—A hood shall be installed immediately adjacent to the door of the fire room. The bottom of the hood shall be level with the top surface of the room. The face dimensions of the hood shall be at least 2440 by 2440 mm (8 by 8 ft), and the depth shall be 1050 mm (3.5 ft). The hood shall feed into a plenum having a 914 by 914 mm (3 by 3 ft) cross section (see Fig. 4). The plenum shall have a minimum height of 914 mm (3 ft). The maximum height is 1830 mm (6 ft). The exhaust duct connected to the plenum shall be 406 mm (16 in.) in diameter, horizontal, and shall have a circular aperture of 305 mm (12 in.) or guide vanes at its entrance (see Fig. 4).

9.2 The hood shall have a draft sufficient to collect all of the combustion products leaving the room by moving at least a standard 2.5 m³/s (5000 ft³/min). Provisions shall be made to vary the draft to change the flow from 1 to 2.5 standard m³/s (2000 to 5000 ft³/min). Mixing vanes shall be required in the duct if concentration gradients are found to exist.

9.3 An alternative exhaust system design is permitted, provided it has been shown to produce equivalent results. (Equivalency is shown by meeting the requirements of 9.2.)

10. Instrumentation in the Exhaust Duct

10.1 Duct Gas Velocity:

10.1.1 *Specification*—A bi-directional probe or an equivalent measuring system shall be used to measure gas velocity in the duct (1).⁵ The probe shown in Fig. 5 consists of a short stainless steel cylinder 44 mm (1¾ in.) long and 22 mm (7/8 in.) inside diameter with a solid diaphragm in the center. The pressure taps on either side of the diaphragm support the probe. The axis of the probe shall be along the centerline of the duct 3350 mm (11 ft) downstream from the entrance. The taps shall be connected to a pressure transducer that shall be able to resolve pressure differences of 0.25 Pa (0.001 in. H₂O). Differential pressure measurements shall be smoothed by filtering the transducer output signal through an RC circuit with a time constant of 5 s. Alternatively, digital

⁵ The boldface numbers in parentheses refer to the list of references at the end of this standard.

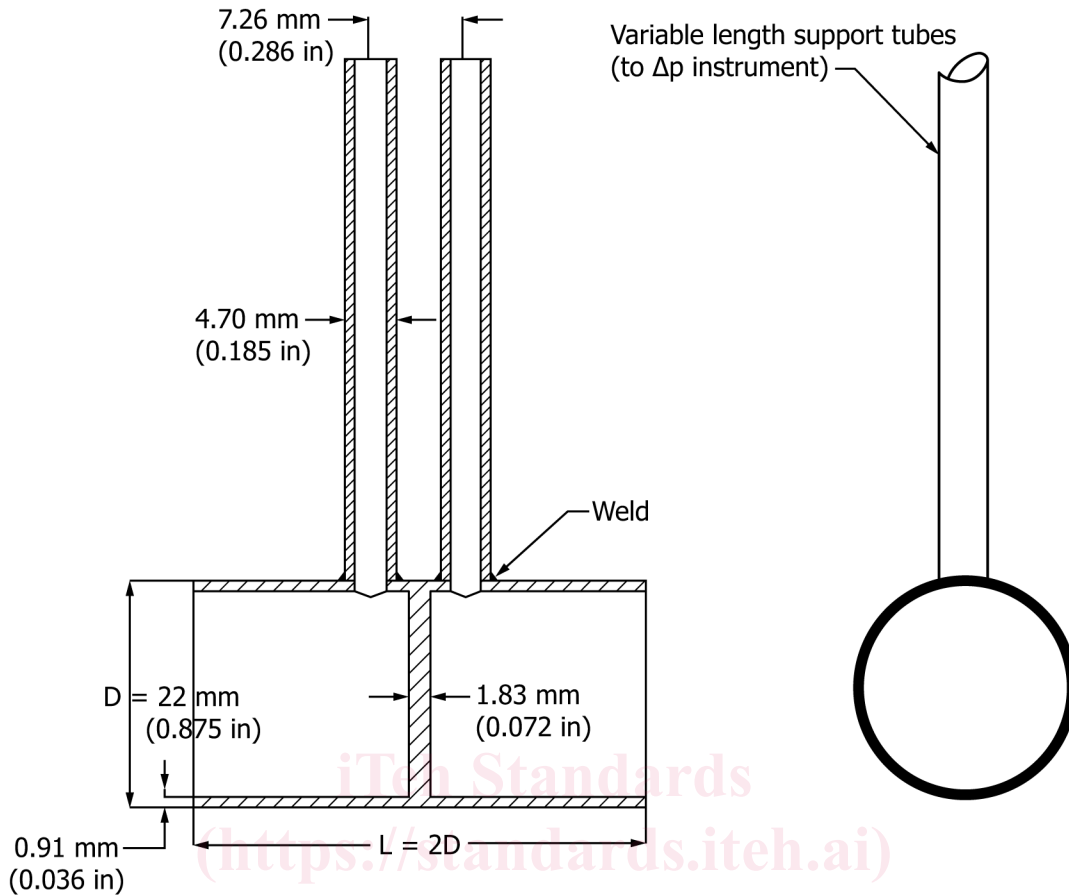

FIG. 5 Bi-directional Probe

filtering of the pressure transducer output signal to simulate the effect of this RC circuit shall be permitted. One pair of thermocouples as specified in 8.3.1 shall be placed 3350 mm (11 ft) downstream of the entrance to the horizontal duct. The pair of thermocouples shall straddle the center of the duct and be separated 50 mm (2 in.) from each other.

NOTE 5—The bi-directional probe was chosen for measuring velocity in the exhaust duct, rather than the Pitot-static tube in order to avoid problems of clogging with soot.

NOTE 6—Capacitance pressure transducers have been found to be most suitable for this application.

10.2 Duct Oxygen Concentration:

10.2.1 *Specification*—A stainless steel gas sampling tube shall be located 3660 mm (12 ft) downstream from the entrance to the duct, to obtain a continuously flowing sample for determining the oxygen concentration of the exhaust gas as a function of time. A suitable filter and cold trap or permeable membrane drier shall be placed in the line ahead of the analyzer, to remove particulates and water. The oxygen analyzer shall be of the paramagnetic type and shall be capable of measuring the oxygen concentration in the range from 21 % down to 15 % with an accuracy of ± 0.01 % in this concentration range. The signal from the oxygen analyzer shall be within 5 % of its final value in 60 s after introducing a step change in composition of the gas stream flowing past the inlet to the sampling tube.

10.3 Duct Carbon Dioxide Concentration:

10.3.1 *Specification*—The gas sampling tube described in 10.2.1, or an alternative tube in the same location, shall provide a continuous sample for the measurement of the carbon dioxide concentration using an analyzer with a range of 0 to 5 %, with a maximum error of 0.1 % of full scale. The signal from the analyzer shall be within 5 % of its final value in 60 s after introducing a step change in composition of the gas stream flowing past the inlet to the sampling tube.

10.4 Duct Carbon Monoxide Concentration:

10.4.1 *Specification*—The gas sampling tube defined in 10.2.1, or an alternative tube in the same location, shall provide a continuous sample for the measurement of the carbon monoxide concentration using an analyzer with a range from 0 to 1 % with a maximum error of ± 0.02 %. The signal from the analyzer shall be within 5 % of its final value in 60 s after introducing a step change in composition of the gas stream flowing past the inlet to the sampling tube.

10.5 Optical Density of Smoke in Duct:

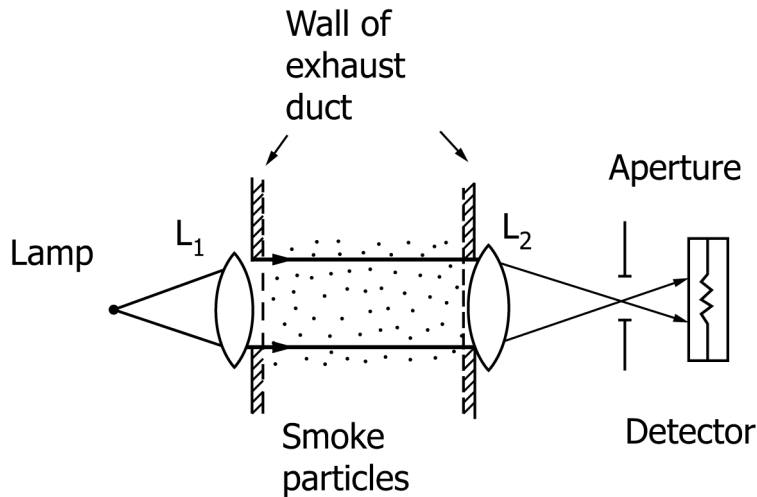

FIG. 6 White-Light Smoke Photometer

10.5.1 A meter shall be installed to measure the optical density of the exhaust gases in a vertical path across the width of a horizontal duct, 600 mm (2 ft) downstream of the duct velocity probe. The optical density shall be continuously recorded over the duration of the test.

10.5.2 One photometer system found suitable consists of a lamp, lenses, an aperture, and a photocell (see Fig. 6). Construct the system so that soot deposit on the optics during a test do not reduce the light transmission by more than 5 %.

10.5.3 Alternatively, instrumentation constructed using a 0.5 to 2.0 mW helium-neon laser, instead of a white-light system, is also acceptable (see Fig. 7).

NOTE 7—It has been shown that white light and laser systems will provide similar results (2).

10.6 *Data Acquisition*—The data collection system used shall have facilities for the recording of the output from the bi-directional probe, the gas analyzers, the heat flux meter, the thermocouples, and the smoke measuring system. The data acquisition system shall have an accuracy corresponding to at least 50 ppm oxygen for the oxygen channel, 0.5°C for the temperature measuring channels, and 0.01 % of full-scale instrument output for all other instrument channels. The system shall be capable of recording data for at least 22 min, at intervals not exceeding 6 s. The system shall be calibrated at least once per year.

11. Specimen Mounting

11.1 Specimen mounting shall be according to one of three configurations (see Appendix X1).

11.1.1 *Standard Configuration*—Specimens shall be mounted to cover the entire ceiling, the two side walls, and the back wall.

11.1.2 *Wall Configuration*—Specimens shall be mounted to completely cover the walls, except the front wall containing the door. The entire ceiling shall be covered with gypsum board with a density of $725 \pm 50 \text{ kg/m}^3$ ($45 \pm 5 \text{ lb/ft}^3$) and a minimum thickness of 13 mm ($\frac{1}{2}$ in.).

11.1.3 *Ceiling Configuration*—Specimens shall be mounted to cover the entire ceiling. The two side walls and the back wall shall be covered entirely with gypsum board with a density of $725 \pm 50 \text{ kg/m}^3$ ($45 \pm 5 \text{ lb/ft}^3$) and a minimum thickness of 13 mm ($\frac{1}{2}$ in.).

11.2 The specimens, for example, the ceiling and wall materials whose contribution is being tested, shall be mounted on a framing or support system comparable to that intended for their field use, using backing materials, insulation, or air gaps, as appropriate to the intended application and representing a typical value of thermal resistance for the wall system. (See Appendix X2.)

11.3 In cases where the product to be tested is in panel form, the standard dimensions (width, length and thickness) of the panels shall be used, if possible.

11.4 Thin surface materials, thermoplastic products that melt, paints and varnishes shall, depending on their end use, be applied to one of the following substrates; (a) Non-combustible fiber reinforced silicate board with a dry density of $680 \pm 50 \text{ kg/m}^3$ ($42 \pm 3 \text{ lb/ft}^3$), suitable thickness is between 9 and 13 mm (and $\frac{1}{2}$ in.); (b) Non-combustible board with a dry density of $1650 \pm 150 \text{ kg/m}^3$ ($103 \pm 9 \text{ lb/ft}^3$), suitable thickness is between 9 and 13 mm (and $\frac{1}{2}$ in.); (c) Ordinary particleboard with a density of $680 \pm 50 \text{ kg/m}^3$ ($42 \pm 3 \text{ lb/ft}^3$) at normal conditioning atmosphere, that is, $50 \pm 5 \%$ of relative humidity and $23 \pm 2^\circ\text{C}$ ($73 \pm 4^\circ\text{F}$) of temperature, suitable thickness is between 9 and 13 mm (and $\frac{1}{2}$ in.); and (d) Gypsum board with a density of $725 \pm 50 \text{ kg/m}^3$ ($45 \pm 5 \text{ lb/ft}^3$) at normal conditioning atmosphere, suitable thickness is between 9 and 13 mm ($\frac{3}{8}$ and $\frac{1}{2}$ in.) Other substrates are acceptable depending on the end use of the product, for example steel and mineral wool.

11.5 Paints and varnishes shall be applied to the appropriate substrate with the application rate specified by the sponsor.

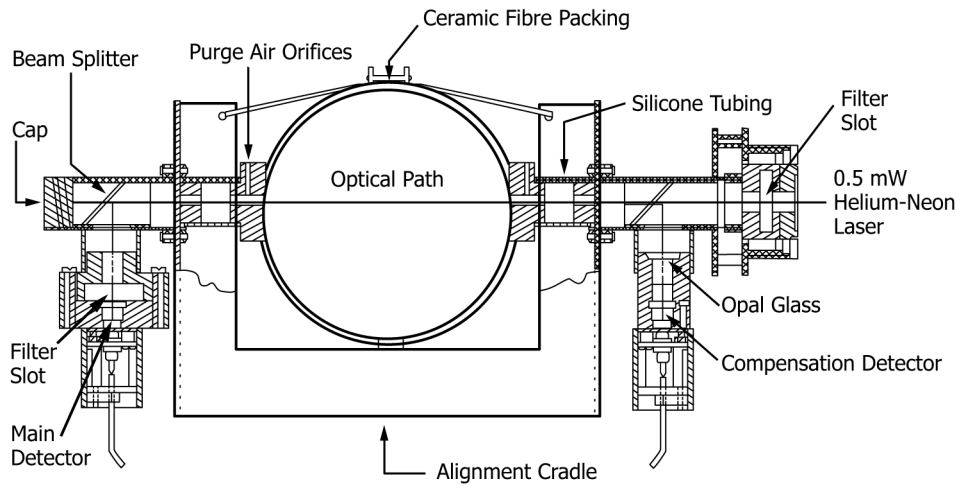

FIG. 7 Laser Smoke Photometer

11.6 A detailed description of the mounting method used shall be given in the test report. If a special mounting technique is used in order to improve the physical behavior of the specimen during the test, this shall be clearly stated in the report.

12. Fire Room Environment

12.1 The temperature in the fire test room and the surroundings shall be $20 \pm 10^\circ\text{C}$.

12.2 The horizontal wind draft measured at a horizontal distance of 1000 mm (40 in.) from the center of the doorway shall not exceed 0.5 m/s (1.6 ft/s).

12.3 When necessary, the specimens shall be conditioned to approximate equilibrium in an atmosphere of $50 \pm 5\%$ relative humidity at a temperature of $23 \pm 2^\circ\text{C}$ ($73 \pm 4^\circ\text{F}$). Equilibrium is considered to be reached when a representative piece of the specimen has achieved constant mass. Constant mass is considered to be reached when two successive weighing operations, carried out at an interval of 24 h, do not differ by more than 0.1 % of the mass of the test piece or 0.1 g, whichever is greater. For wood based products and products where vaporization of solvents occurs, a conditioning time of at least four weeks is not uncommon.

13. Heat Release Rate Calibration

13.1 A heat release rate calibration test shall be performed prior to and within 30 days of any fire test according to the procedure described in Section 14. The calibration test shall use the standard gas burner described in Section 6. The burner shall be placed directly under the center of the hood so that its top surface is 2 m (80 in.) below the bottom of the hood. The propane gas supply to the burner shall produce a net heat output of $300 \pm 10\text{ kW}$ ($17\,060 \pm 570\text{ Btu/min}$) for 10 min. A new value for the calibration constant C shall be obtained as follows:

13.1.1 Determine the rate of heat release according to the equations in Annex A1, using the theoretical value for the calibration constant, C_{th} (see A1.2.2). Determine the average heat release rate over the 10-min calibration test duration, $q_{avg,1}$.

13.1.2 Determine the average rate of heat release over the 10-min test duration, $q_{avg,2}$, from the mass loss of the fuel and its heat of combustion. The net heat of combustion of 99 % purity propane is 46.5 kJ/g ($20000 \pm 200\text{ Btu/lb}$).

13.1.3 Calculate a new value for the calibration constant from:

$$C_{new} = C_{th} \frac{q_{avg,2}}{q_{avg,1}} \quad (1)$$

13.1.4 The difference between C_{new} and C_{th} shall not exceed 20 % of the theoretical value. The difference between C_{new} and the value obtained from the previous calibration, C_{old} , shall not exceed 5 % of the theoretical value. If any of the two differences exceed the limit, the gas sampling system shall be checked for leaks, and the gas analysis and flow measuring instrumentation shall be examined for proper operation. No tests shall be performed until the cause of the discrepancy is found and corrective action is taken.

14. Procedure

14.1 Zero the pressure transducer signal after connecting the two ports of the transducer.

14.2 Establish an initial volumetric flow of $1\text{ m}^3/\text{s}$ ($2000\text{ ft}^3/\text{min}$) through the duct. During the test, increase the volume flow through the duct to $2.5\text{ m}^3/\text{s}$ ($5000\text{ ft}^3/\text{min}$) as necessary to collect all combustion products emerging from the room.

14.3 Calibrate the smoke meter by blocking the light beam (zero) and using a neutral density filter (span). Calibrate the gas analyzers with zero (nitrogen) and span gases (dry air for oxygen and certified mixtures for carbon monoxide and carbon dioxide).