



Designation: **G65—15 G65 – 16**

Standard Test Method for Measuring Abrasion Using the Dry Sand/Rubber Wheel Apparatus¹

This standard is issued under the fixed designation G65; the number immediately following the designation indicates the year of original adoption or, in the case of revision, the year of last revision. A number in parentheses indicates the year of last reapproval. A superscript epsilon (ϵ) indicates an editorial change since the last revision or reapproval.

1. Scope

1.1 This test method covers laboratory procedures for determining the resistance of metallic materials to scratching abrasion by means of the dry sand/rubber wheel test. It is the intent of this test method to produce data that will reproducibly rank materials in their resistance to scratching abrasion under a specified set of conditions.

1.2 Abrasion test results are reported as volume loss in cubic millimetres for the particular test procedure specified. Materials of higher abrasion resistance will have a lower volume loss.

NOTE 1—In order to attain uniformity among laboratories, it is the intent of this test method to require that volume loss due to abrasion be reported only in the metric system as cubic millimetres. $1 \text{ mm}^3 = 6.102 \times 10^{-5} \text{ in}^3$.

1.3 This test method covers five recommended procedures which are appropriate for specific degrees of wear resistance or thicknesses of the test material.

1.3.1 *Procedure A*—This is a relatively severe test which will rank metallic materials on a wide volume loss scale from low to extreme abrasion resistance. It is particularly useful in ranking materials of medium to extreme abrasion resistance.

1.3.2 *Procedure B*—A short-term variation of Procedure A. It may be used for highly abrasive resistant materials but is particularly useful in the ranking of medium- and low-abrasive-resistant materials. Procedure B should be used when the volume-loss values developed by Procedure A exceeds 100 mm^3 .

1.3.3 *Procedure C*—A short-term variation of Procedure A for use on thin coatings.

1.3.4 *Procedure D*—This is a lighter load variation of Procedure A which is particularly useful in ranking materials of low-abrasion resistance. It is also used in ranking materials of a specific generic type or materials which would be very close in the volume loss rates as developed by Procedure A.

1.3.5 *Procedure E*—A short-term variation of Procedure B that is useful in the ranking of materials with medium- or low-abrasion resistance.

1.4 *This standard does not purport to address the safety concerns, if any, associated with its use. It is the responsibility of the user of this standard to establish appropriate safety and health practices and determine the applicability of regulatory limitations prior to use.*

2. Referenced Documents

2.1 *ASTM Standards*:²

[D2000 Classification System for Rubber Products in Automotive Applications](#)

[D2240 Test Method for Rubber Property—Durometer Hardness](#)

[E11 Specification for Woven Wire Test Sieve Cloth and Test Sieves](#)

[E122 Practice for Calculating Sample Size to Estimate, With Specified Precision, the Average for a Characteristic of a Lot or Process](#)

[E177 Practice for Use of the Terms Precision and Bias in ASTM Test Methods](#)

[E691 Practice for Conducting an Interlaboratory Study to Determine the Precision of a Test Method](#)

[G40 Terminology Relating to Wear and Erosion](#)

[G105 Test Method for Conducting Wet Sand/Rubber Wheel Abrasion Tests \(Withdrawn 2016\)](#)³

¹ This test method is under the jurisdiction of ASTM Committee G02 on Wear and Erosion and is the direct responsibility of Subcommittee G02.30 on Abrasive Wear. Current edition approved Nov. 1, 2015/March 1, 2016. Published December 2015/March 2016. Originally approved in 1980. Last previous edition approved in 2010 as G65G65 – 15, –04 (2010)—DOI: 10.1520/G0065-15.10.1520/G0065-16.

² For referenced ASTM standards, visit the ASTM website, www.astm.org, or contact ASTM Customer Service at service@astm.org. For *Annual Book of ASTM Standards* volume information, refer to the standard's Document Summary page on the ASTM website.

³ The last approved version of this historical standard is referenced on www.astm.org.

2.2 American Foundrymen’s Society Standards:
AFS Foundry Sand Handbook, 7th Edition⁴

3. Terminology

3.1 Definitions:

3.1.1 *abrasive wear*—wear due to hard particles or hard protuberances forced against and moving along a solid surface (Terminology G40).

NOTE 2—This definition covers several different wear modes or mechanisms that fall under the abrasive wear category. These modes may degrade a surface by scratching, cutting, deformation, or gouging (1 and 2).⁵

4. Summary of Test Method

4.1 The dry sand/rubber wheel abrasion test (Fig. 1) involves the abrading of a standard test specimen with a grit of controlled size and composition. The abrasive is introduced between the test specimen and a rotating wheel with a chlorobutyl rubber tire or neoprene rubber rim of a specified hardness. This test specimen is pressed against the rotating wheel at a specified force by means of a lever arm while a controlled flow of grit abrades the test surface. The rotation of the wheel is such that its contact face moves in the direction of the sand flow. Note that the pivot axis of the lever arm lies within a plane which is approximately tangent to the rubber wheel surface, and normal to the horizontal diameter along which the load is applied. The test duration and force applied by the lever arm is varied as noted in Procedure A through E. Specimens are weighed before and after the test and the loss in mass recorded. It is necessary to convert the mass loss to volume loss in cubic millimetres, due to the wide differences in the density of materials. Abrasion is reported as volume loss per specified procedure.

5. Significance and Use (1-7)

5.1 The severity of abrasive wear in any system will depend upon the abrasive particle size, shape, and hardness, the magnitude of the stress imposed by the particle, and the frequency of contact of the abrasive particle. In this practice these conditions are standardized to develop a uniform condition of wear which has been referred to as scratching abrasion (1 and 3). The value of the practice lies in predicting the relative ranking of various materials of construction in an abrasive environment. Since the practice does not attempt to duplicate all of the process conditions (abrasive size, shape, pressure, impact, or corrosive elements), it should not be used to predict the exact resistance of a given material in a specific environment. Its value lies in predicting the ranking of materials in a similar relative order of merit as would occur in an abrasive environment. Volume loss data obtained from test materials whose lives are unknown in a specific abrasive environment may, however, be compared with test data obtained from a material whose life is known in the same environment. The comparison will provide a general indication of the worth of the unknown materials if abrasion is the predominant factor causing deterioration of the materials.

ASTM G65-16

⁴ Available from American Foundrymen’s Society, Golf and Wolf Roads, Des Plaines, IL 60016.

⁵ The boldface numbers in parentheses refer to a list of references at the end of this standard.

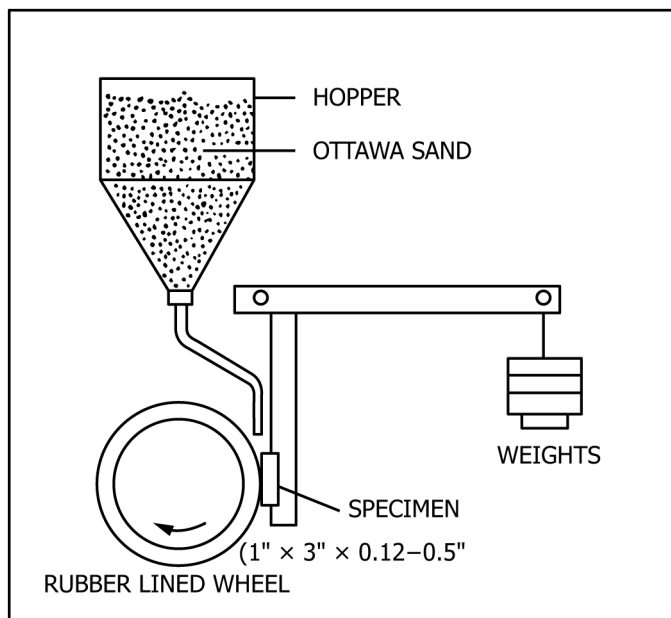

FIG. 1 Schematic Diagram of Test Apparatus

6. Apparatus and Material⁶

6.1 Fig. 2 shows a typical design and Fig. 3 and Fig. 4 are photographs of the test apparatus which may be constructed from readily available materials. Also, see Ref (3). Several elements are of critical importance to ensure uniformity in test results among laboratories. These are the type of rubber used on the wheel, the type of abrasive and the shape, positioning and the size opening of the sand nozzle, and a suitable lever arm system to apply the required force.

6.2 Rubber Wheel—The wheel shown in Fig. 5 shall consist of a steel disk with an outer layer of chlorobutyl or neoprene rubber molded to its periphery. Uncured rubber shall be bonded to the rim and fully cured in a steel mold. The optimum hardness of the cured rubber is Durometer A-60. A range from A58 to 62 is acceptable. At least four hardness readings shall be taken on the rubber approximately 90° apart around the periphery of the wheel using a Shore A Durometer tester in accordance with Test Method D2240. The gage readings shall be taken after a dwell time of 5 s. The recommended composition of the rubber and a qualified molding source is noted in Table 1 and Table 2. (See 9.9 for preparation and care of the rubber wheel before and after use and see Fig. 2 and Fig. 5.)

6.3 Abrasive—The type of abrasive shall be a rounded quartz grain sand as typified by AFS 50/70 Test Sand (Fig. 6).⁷ The moisture content shall not exceed 0.5 weight %. Sand that has been subjected to dampness or to continued high relative humidity may take on moisture, which will affect test results. Moisture content may be determined by measuring the weight loss after heating a sample to approximately 120°C (250°F) for 1 h minimum. If test sand contains moisture in excess of 0.5 % it shall be dried by heating to 100°C (212°F) for 1 h minimum and the moisture test repeated. In high-humidity areas sand may be effectively stored in constant temperature and humidity rooms or in an enclosed steel storage bin equipped with a 100-W electric bulb. Welding

⁶ Original users of this test method fabricated their own apparatus. Machines are available commercially from several manufacturers of abrasion testing equipment.
⁷ Available from U.S. Silica Co., P.O. Box 577, Ottawa, IL 61350. Sand from other sources was not used in the development of this test method and may give different results.

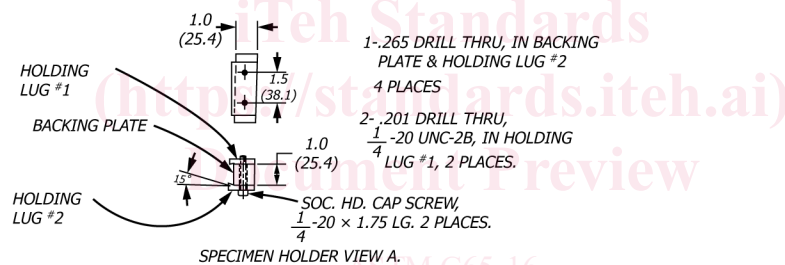

<https://standards.iteh.ai/catalog/standards/sist/8afb2ead-5a44-429d-ba40-a4dfad29330a/astm-g65-16>

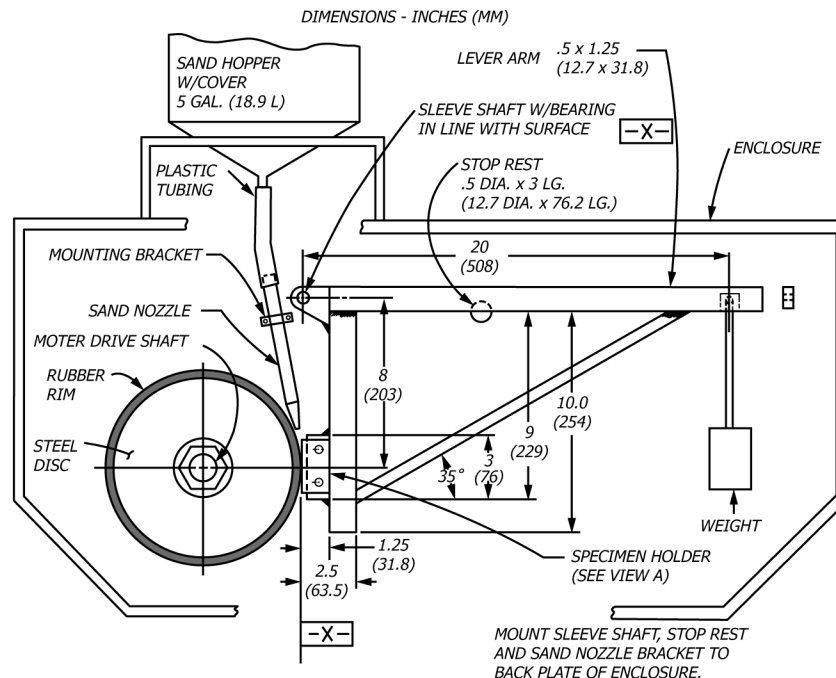

FIG. 2 Dry Sand/Rubber Wheel Abrasion Test Apparatus

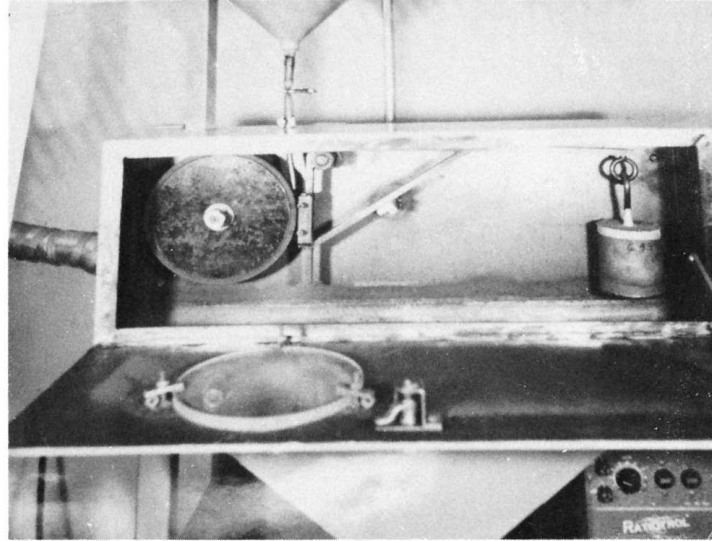

FIG. 3 Wheel and Lever Arm

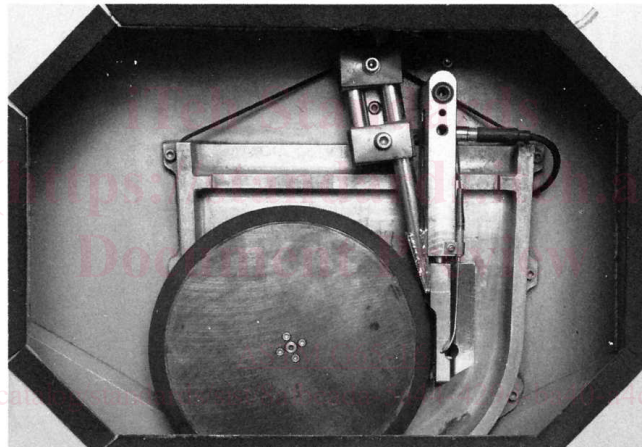

FIG. 4 Enclosure Frame

electrode drying ovens, available from welding equipment suppliers are also suitable. Multiple use of the sand may affect test results and is not recommended. AFS 50/70 Test Sand is controlled to the following size range using U.S. sieves (Specification E11).

U.S. Sieve Size	Sieve Opening	% Retained on Sieve
40	425 μm (0.0165 in.)	none
50	300 μm (0.0117 in.)	5 max
70	212 μm (0.0083 in.)	95 min
100	150 μm (0.0059 in.)	none passing

6.4 *Sand Nozzle*—Fig. 7 shows the fabricated nozzle design which was developed to produce an accurate sand flow rate and proper shape of sand curtain for test procedures. The nozzle may be of any convenient length that will allow for connection to the sand hopper using plastic tubing. In new nozzles, the rate of sand flow is adjusted by grinding the orifice of the nozzle to increase the width of the opening to develop a sand flow rate of 300 to 400 g/min. During use, the nozzle opening must be positioned as close to the junction of the test specimen and the rubber wheel as the design will allow. (See Fig. 8.)

6.4.1 Any convenient material of construction that is available as welded or seamless pipe may be used for the construction of the fabricated nozzle. Stainless steel is preferred because of its corrosion resistance and ease of welding. Copper and steel are also used successfully.

6.4.2 *Formed Nozzle*—Nozzles formed from tubing may be used only when they duplicate the size and shape (rectangular orifice and taper), and the sand flow characteristics (flow rate and streamlined flow) of the fabricated nozzle. (See Fig. 7 and Fig. 9.)

6.4.3 *Sand Flow*—The nozzle must produce a sand flow rate of 300 to 400 g/min (0.66 to 0.88 lb/min).

Dimensions – mm (inches)

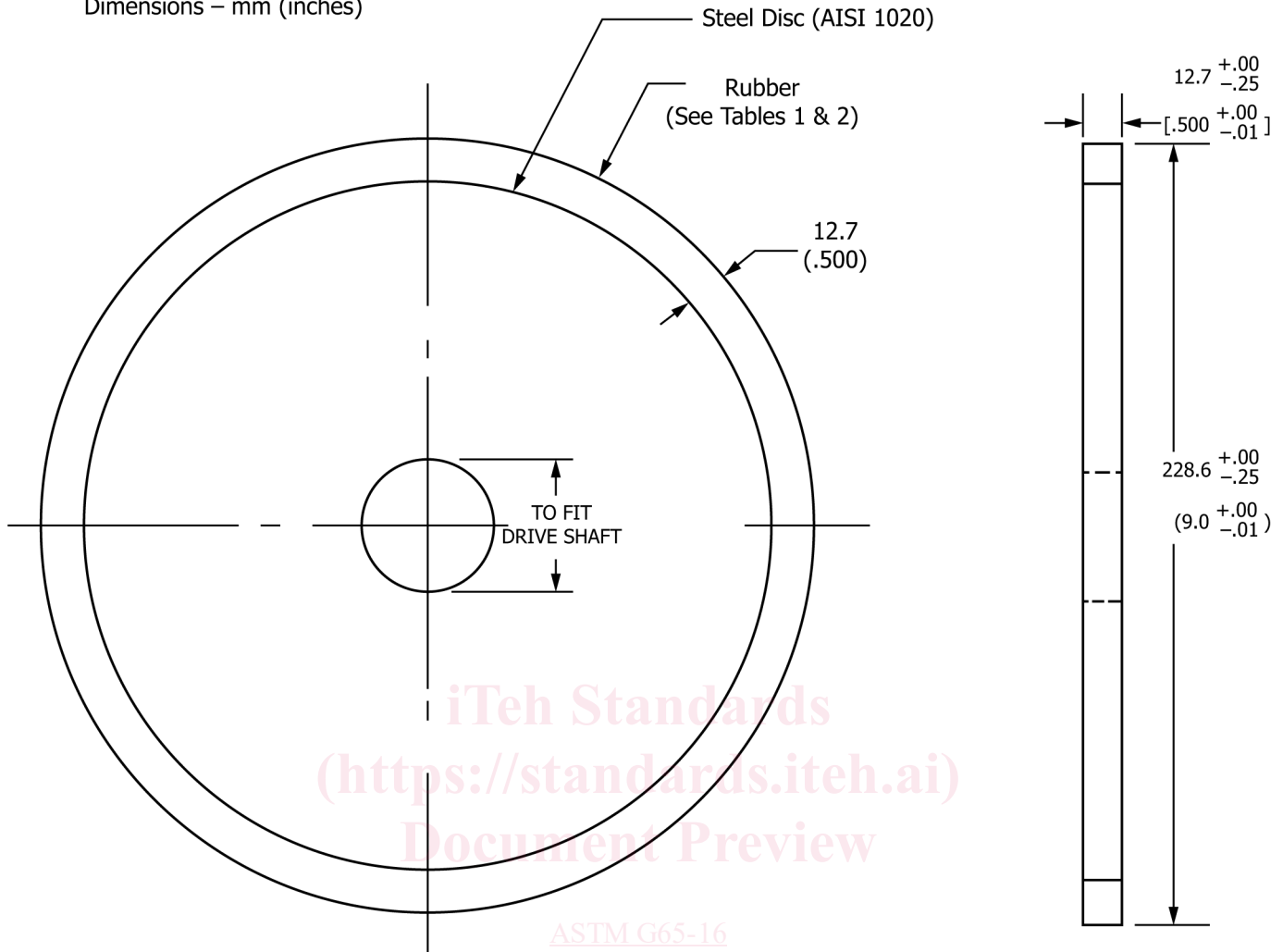

FIG. 5 Rubber Wheel

TABLE 1 A Formula for Chlorobutyl Rubber^A

NOTE 1—Specific gravity of mix: 1.15. Pressure cure: 20 min at 160°C (320°F).

Materials	Proportions by Weight
Chlorobutyl No. HT 10-66 (Enjay Chemical)	100
Agerite Staylite-S	1
HAF black	60
Circolight oil	5
Stearic acid	1
Zinc oxide	5
Ledate	2

^A The sole source of supply known to the committee at this time is Falex Corporation, 1020 Airpark Dr., Sugar Grove, IL 60554. If you are aware of alternative suppliers, please provide this information to ASTM Headquarters. Your comments will receive careful consideration at a meeting of the responsible technical committee, which you may attend.

TABLE 2 Formula for Neoprene Rubber^A

NOTE 1—The rubber will conform to Classification **D2000**.

NOTE 2—The 60 Durometer wheel will be in accordance with 2BC615K11Z1Z2Z3Z4, where Z1—Elastomer—Neoprene GW, Z2—Type A Durometer hardness 60 ± 2, Z3—Not less than 50 % rubber hydrocarbon content, and Z4—Medium thermal black reinforcement.

NOTE 3—The wheels are molded under pressure. Cure times of 40 to 60 min at 153°C (307°F) are used to minimize “heat-to-heat” variations.

Materials	Proportions by Weight
Neoprene GW	100
Magnesia ^B	2
Zinc Oxide ^C	10
Octamine	2
Stearic Acid	0.5
SRF Carbon Black ^D	37
ASTM #3 Oil	10

^A The sole source of supply known to the committee at this time is Falex Corporation, 1020 Airpark Dr., Sugar Grove, IL 60554. If you are aware of alternative suppliers, please provide this information to ASTM Headquarters. Your comments will receive careful consideration at a meeting of the responsible technical committee, which you may attend.

^BMaglite D (Merck)

^CKadox 16 (Ner Jersey Zinc)

^DASTM Grade N762

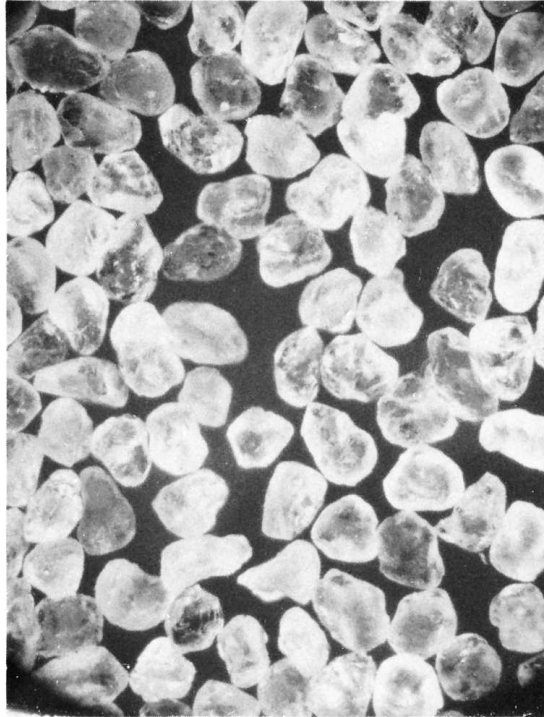

FIG. 6 25X Magnification AFS 50/70 Test Sand Ottawa Silica Co.

6.4.4 *Sand Curtain*—Fig. 9 shows the proper stream-lined flow and the narrow shape of the sand curtain as it exits from the sand nozzle. A turbulent sand flow as depicted in Fig. 10 will tend to produce low and inconsistent test results. It is intended that the sand flows in a streamlined manner and passes between the specimen and rubber wheel.

6.5 *Motor Drive*—The wheel is driven by a nominally 0.7-kW (1-hp) dc motor through a 10/1 gear box to ensure that full torque is delivered during the test. The rate of revolution (200 ± 10 rpm) must remain constant under load. Other drives producing 200 rpm under load are suitable.

6.6 *Wheel Revolution Counter*—The machine shall be equipped with a revolution counter that will monitor the number of wheel revolutions as specified in the procedure (Section 9). It is recommended that the incremental counter have the ability to shut off the machine after a preselected number of wheel revolutions or increments up to 12 000 revolutions is attained.

6.7 *Specimen Holder and Lever Arm*—The specimen holder is attached to the lever arm to which weights are added, so that a force is applied along the horizontal diametral line of the wheel. An appropriate number of weights must be available to apply the appropriate force (Table 23) between the test specimen and the wheel. The actual weight required should not be calculated, but rather should be determined by direct measurement by noting the load required to pull the specimen holder away from the wheel. A convenient weight system is a can filled with sand (see Fig. 2).

6.8 *Analytical Balance*—The balance used to measure the loss in mass of the test specimen shall have a sensitivity of 0.001 g. Procedure C requires a sensitivity of 0.0001 g.

6.9 *Enclosure, Frame, and Abrasive Hopper*—Fig. 3 and Fig. 4 are photographs of a typical test apparatus. The size and shape of the support elements, enclosure, and hopper may be varied according to the user's needs.

7. Specimen Preparation and Sampling

7.1 *Materials*—It is the intent of this test method to allow for the abrasion testing of any material form, including wrought metals, castings, forgings, gas or electric weld overlays, plasma spray deposits, powder metals, metallizing, electroplates, cermets, ceramics and so forth. The type of material will, to some extent, determine the overall size of the test specimen.

7.2 *Typical Specimen*, a rectangular shape 25 by 76 mm (1.0 by 3.0 in.) and between 3.2 and 12.7 mm (0.12 and 0.50 in.) thick. The size may be varied according to the user's need with the restriction that the length and width be sufficient to show the full length of the wear scar as developed by the test. The test surface should be flat within 0.125 mm (0.005 in.) maximum.

7.3 *Wrought, Cast, and Forged Metal*—Specimens may be machined to size directly from the raw material.