



Designation: C173/C173M – 16

Standard Test Method for Air Content of Freshly Mixed Concrete by the Volumetric Method¹

This standard is issued under the fixed designation C173/C173M; the number immediately following the designation indicates the year of original adoption or, in the case of revision, the year of last revision. A number in parentheses indicates the year of last reapproval. A superscript epsilon (ϵ) indicates an editorial change since the last revision or reapproval.

This standard has been approved for use by agencies of the U.S. Department of Defense.

1. Scope*

1.1 This test method covers determination of the air content of freshly mixed concrete containing any type of aggregate, whether it be dense, cellular, or lightweight.

1.2 The values stated in either SI units or inch-pound units are to be regarded separately as standard. The inch-pound units are shown in brackets. The values stated in each system may not be exact equivalents; therefore, each system shall be used independently of the other. Combining values from the two systems may result in non-conformance with the standard.

1.3 *This standard does not purport to address all of the safety concerns, if any, associated with its use. It is the responsibility of the user of this standard to establish appropriate safety and health practices and determine the applicability of regulatory limitations prior to use. (Warning—Fresh hydraulic cementitious mixtures are caustic and may cause chemical burns to skin and tissue upon prolonged exposure.²)*

2. Referenced Documents

2.1 *ASTM Standards:*³

[C29/C29M Test Method for Bulk Density \(“Unit Weight”\) and Voids in Aggregate](#)

[C31/C31M Practice for Making and Curing Concrete Test Specimens in the Field](#)

[C138/C138M Test Method for Density \(Unit Weight\), Yield, and Air Content \(Gravimetric\) of Concrete](#)

[C143/C143M Test Method for Slump of Hydraulic-Cement Concrete](#)

[C172 Practice for Sampling Freshly Mixed Concrete](#)

¹ This test method is under the jurisdiction of ASTM Committee C09 on Concrete and Concrete Aggregates and is the direct responsibility of Subcommittee C09.60 on Testing Fresh Concrete.

Current edition approved Feb. 1, 2016. Published March 2016. Originally approved in 1942. Last previous edition approved in 2014 as C173/C173M – 14. DOI: 10.1520/C0173_C0173M-16.

² Section on Safety Precautions, Manual of Aggregate and Concrete Testing, *Annual Book of ASTM Standards*, Vol 04.02.

³ For referenced ASTM standards, visit the ASTM website, www.astm.org, or contact ASTM Customer Service at service@astm.org. For *Annual Book of ASTM Standards* volume information, refer to the standard’s Document Summary page on the ASTM website.

[C173/C173M Test Method for Air Content of Freshly Mixed Concrete by the Volumetric Method](#)

[C231 Test Method for Air Content of Freshly Mixed Concrete by the Pressure Method](#)

[C670 Practice for Preparing Precision and Bias Statements for Test Methods for Construction Materials](#)

[C1064/C1064M Test Method for Temperature of Freshly Mixed Hydraulic-Cement Concrete](#)

3. Significance and Use

3.1 This test method covers the determination of the air content of freshly mixed concrete. It measures the air contained in the mortar fraction of the concrete, but is not affected by air that may be present inside porous aggregate particles.

3.1.1 Therefore, this is the appropriate test to determine the air content of concretes containing lightweight aggregates, air-cooled slag, and highly porous or vesicular natural aggregates.

3.2 This test method requires the addition of sufficient isopropyl alcohol, when the meter is initially being filled with water, so that after the first or subsequent rollings little or no foam collects in the neck of the top section of the meter. If more foam is present than that equivalent to 2 % air above the water level, the test is declared invalid and must be repeated using a larger quantity of alcohol. Addition of alcohol to dispel foam any time after the initial filling of the meter to the zero mark is not permitted.

3.3 The air content of hardened concrete may be either higher or lower than that determined by this test method. This depends upon the methods and amounts of consolidation effort applied to the concrete from which the hardened concrete specimen is taken; uniformity and stability of the air bubbles in the fresh and hardened concrete; accuracy of the microscopic examination, if used; time of comparison; environmental exposure; stage in the delivery, placement and consolidation processes at which the air content of the unhardened concrete is determined, that is, before or after the concrete goes through a pump; and other factors.

*A Summary of Changes section appears at the end of this standard

4. Apparatus

4.1 *Air Meter*—An air meter consisting of a measuring bowl and a top section (Fig. 1) conforming to the following requirements:

4.1.1 The measuring bowl and top sections shall be of sufficient thickness and rigidity to withstand rough field use. The material shall not be attacked by high pH cement paste, deform when stored at high temperatures in closed spaces, or become brittle or crack at low temperatures. A watertight seal must be obtained when the top section is attached to the measuring bowl.

4.1.2 *Measuring Bowl*—The measuring bowl shall have a diameter equal to 1 to 1.25 times the height and be constructed with a flange at or near the top surface. Measuring bowls shall not have a capacity of less than 2.0 L [0.075 ft³].

4.1.3 *Top Section*—The top section shall have a capacity at least 20 % larger than the measuring bowl and shall be equipped with a flexible gasket and a device to attach the top section to the measuring bowl. The top section shall be equipped with a transparent scale, graduated in increments not

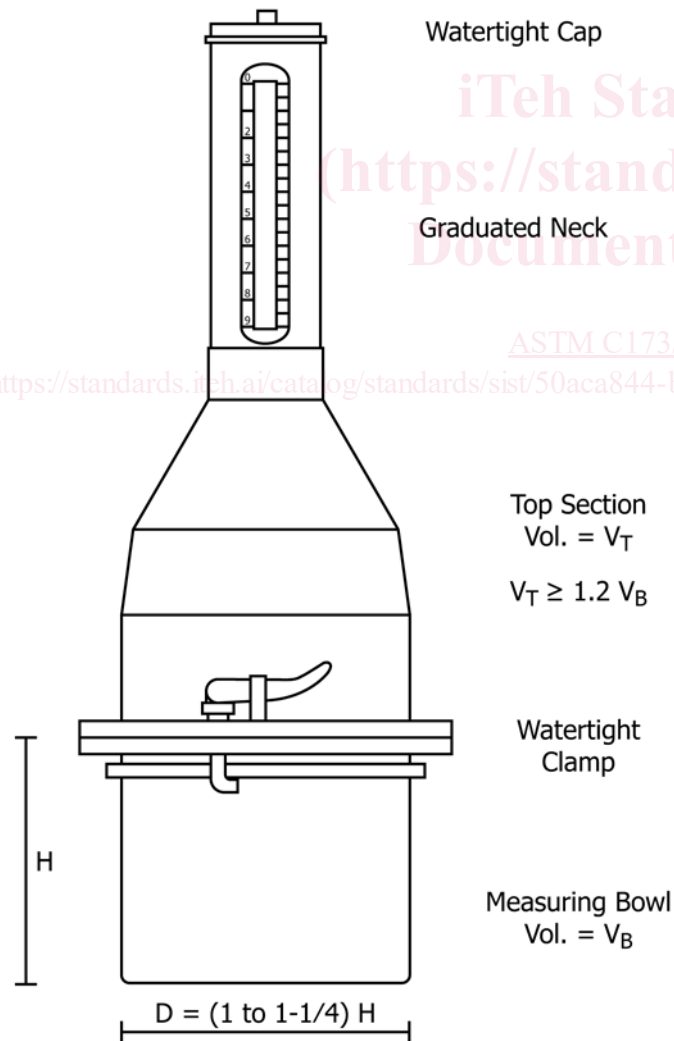

FIG. 1 Apparatus for Measuring Air Content of Fresh Concrete by Volumetric Method (a) Brass Meter

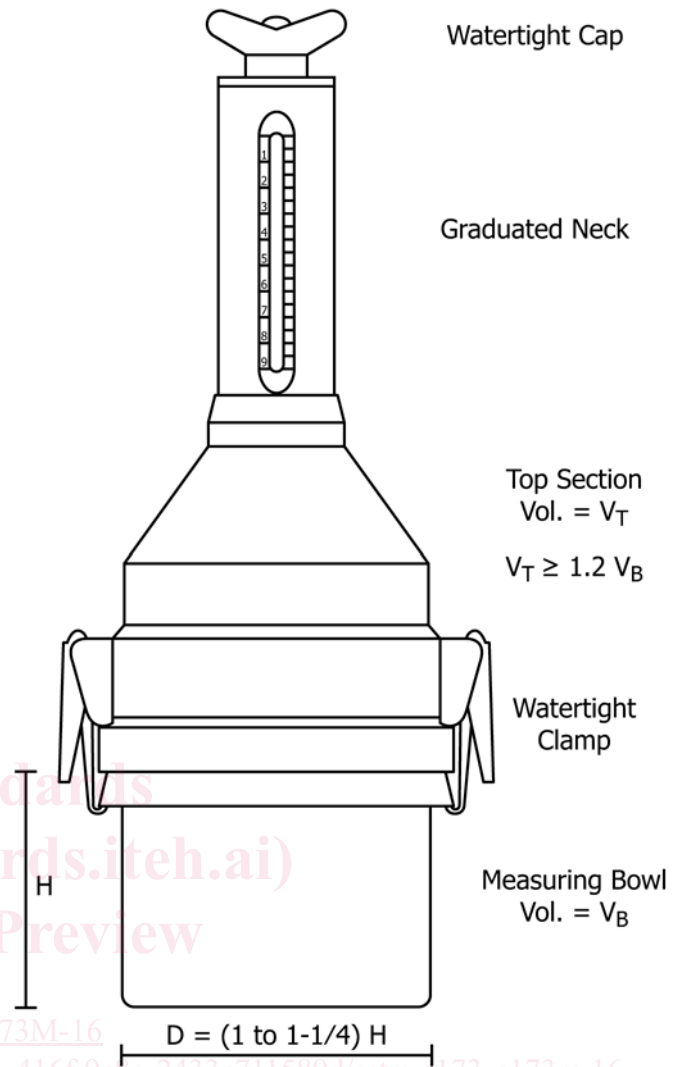

FIG. 1 Apparatus for Measuring Air Content of Fresh Concrete by Volumetric Method (b) Aluminum Meter (continued)

greater than 0.5 % from 0 at the top to 9 %, or more, of the volume of the measuring bowl. Graduations shall be accurate to ± 0.1 % by volume of the measuring bowl. The upper end of the neck shall have a watertight cap that will maintain a watertight seal when the meter is inverted and rolled.

4.2 *Funnel*—A funnel with a spout of a size permitting it to be inserted through the neck of the top section and long enough to extend to a point just above the bottom of the top section. The discharge end of the spout shall be so constructed that when water is added to the container there will be a minimum disturbance of the concrete.

4.3 *Tamping Rod*—A round, smooth, straight steel, high-density polyethylene, or other plastic rod of equal or greater abrasion resistance with a 16 mm [$\frac{5}{8}$ in.] \pm 2 mm [$\frac{1}{16}$ in.] diameter. The length of the tamping rod shall be at least 100 mm [4 in.] greater than the depth of the measuring bowl in which rodding is being performed, but not greater than 600 mm [24 in.] in overall length (Note 1). The rod shall have the

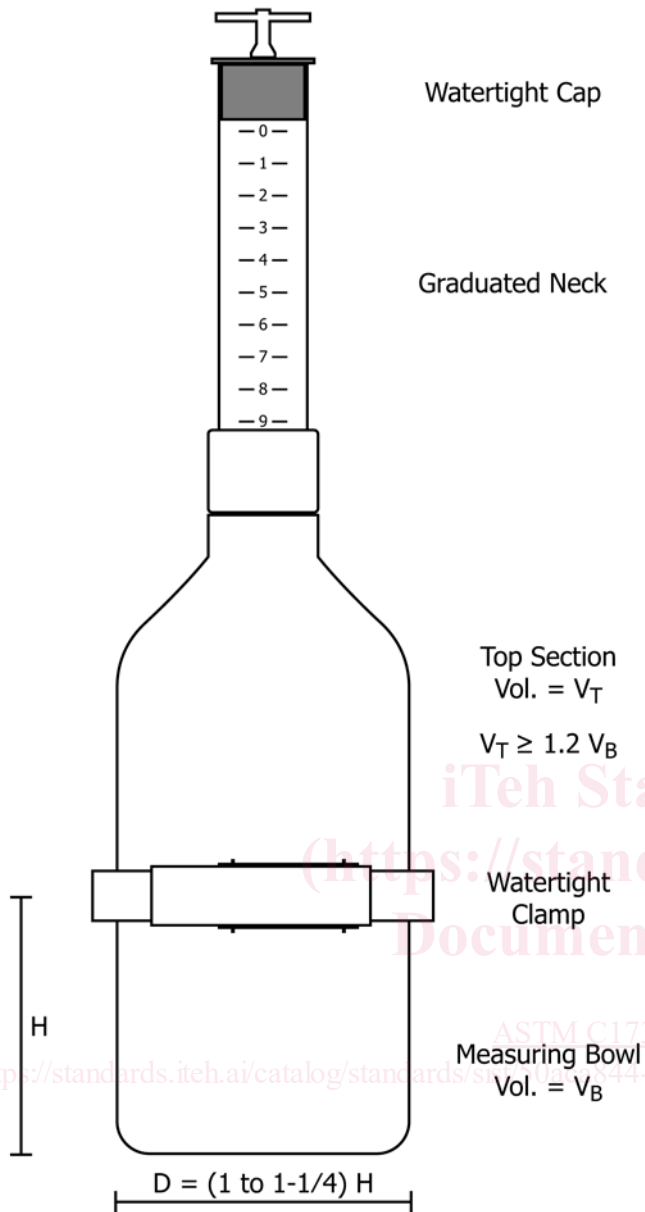

FIG. 1 Apparatus for Measuring Air Content of Fresh Concrete by Volumetric Method (c) High Density Plastic Meter (continued)

tamping end or both ends rounded to a hemispherical tip of the same diameter as the rod.

NOTE 1—A rod length of 400 mm [16 in.] to 600 mm [24 in.] meets the requirements of the following: Practice C31/C31M, Test Method C138/C138M, Test Method C143/C143M, Test Method C173/C173M, and Test Method C231.

4.4 *Strike-off Bar*—A flat, straight steel bar at least 3 by 20 by 300 mm [$\frac{1}{8}$ by $\frac{3}{4}$ by 12 in.] or a flat, straight high-density polyethylene bar, or other plastic of equal or greater abrasion resistance, at least 6 by 20 by 300 mm [$\frac{1}{4}$ by $\frac{3}{4}$ by 12 in.].

4.5 *Calibrated Cup*—A metal or plastic cup either having a capacity of or being graduated in increments equal to 1.00 ± 0.04 % of the volume of the measuring bowl of the air meter. The calibrated cup is only to be used to add water when the concrete air content exceeds 9 % or the calibrated range of the meter.

4.6 *Measuring Vessel for Isopropyl Alcohol*—A vessel with a minimum capacity of at least 500 mL [1 pt] with graduations not larger than 100 mL [4 oz] for measuring a quantity of isopropyl alcohol.

4.7 *Syringe*—A rubber syringe having a capacity of at least 50 mL [2 oz].

4.8 *Pouring Vessel for Water*—A container of approximately 1 L [1 qt] capacity.

4.9 *Scoop* of a size large enough so each amount of concrete obtained from the sampling receptacle is representative and small enough so it is not spilled during placement in the measuring bowl.

4.10 *Isopropyl Alcohol*—Use 70 % by volume isopropyl alcohol (approximately 65 % by weight) (Note 2). Other foam-dispersing agents are permitted if tests demonstrate that the use of the agent does not change the indicated air content, in the amounts being used, by more than 0.1 % or if correction factors are developed similar to those in Table 1. When other dispersing agents are used, a copy of the records documenting the testing or calculations shall be available in the laboratory.

NOTE 2—Seventy percent isopropyl alcohol is commonly available as rubbing alcohol. More concentrated grades can be diluted with water to the required concentration.

4.11 *Mallet*—A mallet (with a rubber or rawhide head) with a mass of approximately 600 ± 200 g [1.25 ± 0.5 lb].

5. Calibration

5.1 Calibrate the meter and calibrated cup initially and annually or whenever there is reason to suspect damage or deformation of the meter or calibrated cup.

5.2 Determine the volume of the measuring bowl with an accuracy of at least 0.1 % by determining the mass of water required to fill it at room temperature and dividing it by the density of the water at the same temperature. Follow the calibration procedure outlined in Test Method C29/C29M.

5.3 Determine the accuracy of the graduations on the neck of the top section of the air meter by filling the assembled measuring bowl and top section with water to the level of the mark for highest air content graduation.

5.3.1 Add water in increments of 1.0 % of the volume of the measuring bowl to check accuracy throughout the graduated range of air content. The error at any point throughout the graduated range shall not exceed 0.1 % of air.

TABLE 1 Correction for the Effect of Isopropyl Alcohol on C173/C173M Air Meter Reading

Pints	70 % Isopropyl Alcohol Used		Correction, % ^A
	Fluid Ounces	Litres	
≤ 2.0	≤ 32	≤ 1.0	0.0 ^B
3.0	48	1.5	0.25
4.0	64	2.0	0.50
5.0	80	2.5	0.75

^A Subtract from final meter reading.

^B Corrections are applied only when 1.25 L [2.5 pt] or more of isopropyl alcohol is used. The values given are for air meters that have a measuring bowl volume of 2.1 L [0.075 ft³] and a top section that is 1.2 times the volume of the measuring bowl.

5.4 Determine the volume of the calibrated cup using water at 21.1°C [70°F] by the method outlined in 5.2. A quick check can be made by adding one or more calibrated cups of water to the assembled apparatus and observing the increase in the height of the water column after filling to a given level.

6. Sampling

6.1 Obtain the sample of freshly mixed concrete in accordance with Practice C172. If the concrete contains coarse aggregate particles that would be retained on a 37.5-mm [1½-in.] sieve, wet sieve a representative sample over a 25-mm [1-in.] sieve to yield somewhat more than enough material to fill the measuring bowl. The wet sieving procedure is described in Practice C172.

6.2 The concrete used to fill the measuring bowl shall not have been previously used in the performance of any other test or practice, other than wet sieving in accordance with Practice C172 or the temperature test in accordance with Test Method C1064/C1064M.

7. Procedure

7.1 *Rodding and Tapping*—Dampen the interior of the measuring bowl and remove any standing water from the bottom. Using the scoop described in 4.9, fill the measuring bowl with freshly mixed concrete in two layers of approximately equal volume. While placing the concrete in the measuring bowl, move the scoop around the perimeter of the measuring bowl opening to ensure an even distribution of the concrete with minimal segregation. Rod each layer 25 times uniformly over the cross section with the rounded end of the rod. Rod the bottom layer throughout its depth. In rodding this layer, use care not to damage the bottom of the measuring bowl. For the upper layer, allow the rod to penetrate through the layer being rodded and into the layer below approximately 25 mm [1 in.]. After each layer is rodded, tap the sides of the measuring bowl 10 to 15 times with the mallet to close any voids left by the tamping rod and to release any large bubbles of air that may have been trapped. After tapping the final layer, a slight excess of concrete, 3 mm [⅛ in.] or less, above the rim is acceptable. Add or remove a representative sample of concrete if necessary to obtain the required amount of concrete.

7.2 *Striking Off*—After rodding and tapping of the second layer, strike off the excess concrete with the strike-off bar until the surface is flush with the top of the measuring bowl. Wipe the flange of the measuring bowl clean.

7.3 *Adding Water and Alcohol*—Wet the inside of the top section of the meter, including the gasket. Attach the top section to the measuring bowl and insert the funnel. Add at least 0.5 L [1 pt] of water followed by the selected amount (Note 3) of isopropyl alcohol. Record the amount of isopropyl alcohol added. Continue adding water at least until it appears in the graduated neck of the top section (Note 4). Remove the funnel. Adjust the liquid level until the bottom of the meniscus is level with the zero mark on the graduated neck. A rubber syringe is useful for this purpose. Attach and tighten the watertight cap.

NOTE 3—The amount of isopropyl alcohol necessary to obtain a stable

reading, and a minimum amount of foam immediately above the water column, will depend upon a number of factors. Many concretes made with less than 300 kg/m³ [500 lb/yd³] of cement and air contents less than 4 % may require less than 0.2 L [0.5 pt] of alcohol. Some high-cement mixes made with silica fume that have air contents of 6 % or more may require more than 1.4 L [3 pt] of alcohol. The amount required will vary with the concrete air content, the amount and type of air-entraining admixture, the cement content and cement alkali content, and perhaps other factors. Generally, the amount of alcohol necessary can be established for given mixture proportions and should not change greatly during the course of a job.

NOTE 4—When, if ever, it is necessary to use more than 2.0 L [4 or 4.5 pt] of isopropyl alcohol, it may be necessary to restrict the amount of water added initially to avoid overfilling the meter. However, it is desirable to add at least some water initially to aid in mixing the alcohol and limit the contact of the concentrated alcohol with the top surface of the concrete.

7.4 *Displacing the Volume of Air in the Concrete Specimen Using These Procedures:*

7.4.1 *Free the Concrete from the Measuring Bowl*—Quickly invert the meter, shake the measuring bowl horizontally, and return the meter to the upright position. To prevent the aggregate from lodging in the neck of the unit, do not keep it inverted for more than 5 s at a time. Repeat the inversion and shaking process for a minimum of 45 s and until the concrete has broken free and the aggregate can be heard moving in the meter as it is inverted.

7.4.2 *Rolling*—Place one hand on the neck of the meter and the other on the flange. Using the hand on the neck, tilt the top of the meter approximately 0.8 rad [45°] from the vertical position with the bottom edge of the measuring bowl resting on the floor or on the work surface. Maintain this position through the procedures described in this section. Using the hand on the flange to rotate the meter, vigorously roll the meter ¼ to ½ turn forward and back several times, quickly starting and stopping the roll. Turn the measuring bowl about ⅓ turn and repeat the rolling procedure as stated previously. Continue the turning and rolling procedures for approximately 1 min. The aggregate must be heard sliding in the meter during this process.

7.4.2.1 If, at any time, during the inversion and rolling procedures liquid is found to be leaking from the meter, the test is invalid and a new test shall be started as in 6.1.

7.4.2.2 Set the unit upright and loosen the top to allow any pressure to stabilize. Allow the meter to stand while the air rises to the top and until the liquid level stabilizes. The liquid level is considered stable when it does not change more than 0.25 % air within a 2-min period.

7.4.2.3 If it takes more than 6 min for the liquid level to stabilize or if there is more foam than that equivalent to 2 full percent air content divisions on the meter scale over the liquid level, discard the trial and start a new test as in 6.1. Use a larger addition of alcohol than was used in the initial trial.

7.4.2.4 If the level is stable without excessive foam, read the bottom of the meniscus to the nearest 0.25 % and record the *initial meter reading*.

7.4.2.5 If the air content is greater than the 9 % range of the meter, add a sufficient number of calibrated cups of water to bring the liquid level within the graduate range. Read the bottom of the meniscus to the nearest 0.25 %. Record the number of calibrated cups of water to be added to the final meter reading in 8.2.