



Designation: **D1883—14 D1883—16**

Standard Test Method for California Bearing Ratio (CBR) of Laboratory-Compacted Soils¹

This standard is issued under the fixed designation D1883; the number immediately following the designation indicates the year of original adoption or, in the case of revision, the year of last revision. A number in parentheses indicates the year of last reapproval. A superscript epsilon (ϵ) indicates an editorial change since the last revision or reapproval.

This standard has been approved for use by agencies of the U.S. Department of Defense.

1. Scope*

1.1 This test method covers the determination of the California Bearing Ratio (CBR) of pavement subgrade, subbase, and base course materials from laboratory compacted specimens. The test method is primarily intended for, but not limited to, evaluating the strength of materials having maximum particle size less than $\frac{3}{4}$ in. (19 mm).

1.2 When materials having a maximum particle size greater than $\frac{3}{4}$ in. (19 mm) are to be tested, this test method provides for modifying the gradation of the material so that the material used for testing all passes the $\frac{3}{4}$ -in. (19-mm) sieve while the total gravel (3 in. (75 mm) to plus No. 4 (4.75 mm)) fraction (material passing the 3-in. (75-mm) sieve and retained on the No. 4 (4.75-mm) sieve) remains the same. While traditionally this method of specimen preparation has been used to avoid the error inherent in testing materials containing large particles in the CBR test apparatus, the modified material may have significantly different strength properties than the original material. However, a large experience database has been developed using this test method for materials for which the gradation has been modified, and satisfactory design methods are in use based on the results of tests using this procedure.

1.3 Past practice has shown that CBR results for those materials having substantial percentages of particles retained on the No. 4 (4.75 mm) sieve are more variable than for finer materials. Consequently, more trials may be required for these materials to establish a reliable CBR.

1.4 This test method provides for the determination of the CBR of a material at optimum water content or a range of water content from a specified compaction test and a specified dry unit weight. The dry unit weight is usually given as a percentage of maximum dry unit weight determined by Test Methods **D698** or **D1557**.

1.5 The client requesting the test may specify the water content or range of water contents and the dry unit weight for which the CBR is desired.

1.6 Unless specified otherwise by the requesting client, or unless it has been shown to have no effect on test results for the material being tested, all specimens shall be soaked prior to penetration.

1.7 For the determination of CBR of field in-place materials, see Test Method **D4429**.

1.8 *Units*—The values stated in inch-pound units are to be regarded as standard. The SI units given in parentheses are mathematical conversions, which are provided for information purposes only and are not considered standard. Reporting of test results in units other than inch-pound units shall not be regarded as nonconformance with this test method.

1.8.1 The gravitational system of inch-pound units is used when dealing with inch-pound units. In this system, the pound (lbf) represents a unit of force (weight), while the unit for mass is slugs. The slug unit is not given, unless dynamic ($F = ma$) calculations are involved.

1.8.2 The slug unit of mass is almost never used in commercial practice; that is, density, balances, etc. Therefore, the standard unit for mass in this standard is either kilogram (kg) or gram (g), or both. Also, the equivalent inch-pound unit (slug) is not given/presented in parentheses.

1.8.3 It is common practice in the engineering/construction profession, in the United States, to concurrently use pounds to represent both a unit of mass (lbm) and of force (lbf). This implicitly combines two separate systems of units; that is, the absolute system and the gravitational system. It is scientifically undesirable to combine the use of two separate sets of inchpound units

¹ This test method is under the jurisdiction of ASTM Committee **D18** on Soil and Rock and is the direct responsibility of Subcommittee **D18.05** on Strength and Compressibility of Soils.

Current edition approved Dec. 1, 2014; March 1, 2016. Published January 2015; March 2016. Originally approved in 1961. Last previous edition approved in 2007 as **D1883—07 D1883—14**; 2014 as **D1883—14**. DOI: 10.1520/D1883-14.10.1520/D1883-16.

*A Summary of Changes section appears at the end of this standard

within a single standard. As stated, this standard includes the gravitational system of inch-pound units and does not use/present the slug unit for mass. However, the use of balances or scales recording pounds of mass (lbm) or recording density in lbm/ft³ shall not be regarded as nonconformance with this standard.

1.8.4 The terms density and unit weight are often used interchangeably. Density is mass per unit volume whereas unit weight is force per unit volume. In this standard, density is given only in SI units. After the density has been determined, the unit weight is calculated in SI or inch-pound units, or both.

1.9 All observed and calculated values shall conform to the guidelines for significant digits and rounding established in Practice **D6026**.

1.9.1 The procedures used to specify how data are collected/recorded or calculated in this standard are regarded as the industry standard. In addition they are representative of the significant digits that generally should be retained. The procedures used do not consider material variation, purpose for obtaining the data, special purpose studies, or any considerations for the user's objectives, and it is common practice to increase or reduce significant digits of reported data to be commensurate with these considerations. It is beyond the scope of this standard to consider significant digits used in analytical methods for engineering design.

1.10 *This standard does not purport to address all of the safety concerns, if any, associated with its use. It is the responsibility of the user of this standard to establish appropriate safety and health practices and determine the applicability of regulatory limitations prior to use.*

2. Referenced Documents

2.1 *ASTM Standards:*²

[C670 Practice for Preparing Precision and Bias Statements for Test Methods for Construction Materials](#)

[D422 Test Method for Particle-Size Analysis of Soils \(Withdrawn 2016\)](#)³

[D653 Terminology Relating to Soil, Rock, and Contained Fluids](#)

[D698 Test Methods for Laboratory Compaction Characteristics of Soil Using Standard Effort \(12,400 ft-lbf/ft³ \(600 kN-m/m³\)\)](#)

[D1557 Test Methods for Laboratory Compaction Characteristics of Soil Using Modified Effort \(56,000 ft-lbf/ft³ \(2,700 kN-m/m³\)\)](#)

[D2168 Practices for Calibration of Laboratory Mechanical-Rammer Soil Compactors](#)

[D2216 Test Methods for Laboratory Determination of Water \(Moisture\) Content of Soil and Rock by Mass](#)

[D2487 Practice for Classification of Soils for Engineering Purposes \(Unified Soil Classification System\)](#)

[D2488 Practice for Description and Identification of Soils \(Visual-Manual Procedure\)](#)

[D3740 Practice for Minimum Requirements for Agencies Engaged in Testing and/or Inspection of Soil and Rock as Used in Engineering Design and Construction](#)

[D4318 Test Methods for Liquid Limit, Plastic Limit, and Plasticity Index of Soils](#)

[D4429 Test Method for CBR \(California Bearing Ratio\) of Soils in Place](#)

[D4753 Guide for Evaluating, Selecting, and Specifying Balances and Standard Masses for Use in Soil, Rock, and Construction Materials Testing](#)

[D6026 Practice for Using Significant Digits in Geotechnical Data](#)

[E11 Specification for Woven Wire Test Sieve Cloth and Test Sieves](#)

3. Terminology

3.1 *Definitions:*

3.1.1 For common definitions of terms in this standard, refer to Terminology **D653**.

3.2 *Definitions of Terms Specific to This Standard:*

3.2.1 *water content of the compaction specimen*, w_c —water content in percent of material used to compact the test specimen.

3.2.2 *water content top 1 in. (25.4-mm) after soaking* w_s —water content in percent of upper 1 in. (25.4 mm) of material removed from the compacted specimen after soaking and penetration.

3.2.3 *water content after testing*, w_f —water content in percent of the compacted specimen after soaking and final penetration; does not include material described in **3.2.2**.

3.2.4 *dry density as compacted and before soaking*, ρ_{di} —dry density of the as compacted test specimen using the measured wet mass and calculating the dry mass using the water content defined in **3.2.1**.

4. Summary of Test Method

4.1 The California Bearing Ratio (CBR) test is used in evaluating subgrade, subbase and base materials as an aid to the design of pavements. The laboratory test uses a circular piston to penetrate material compacted in a mold at a constant rate of penetration.

² For referenced ASTM standards, visit the ASTM website, www.astm.org, or contact ASTM Customer Service at service@astm.org. For *Annual Book of ASTM Standards* volume information, refer to the standard's Document Summary page on the ASTM website.

³ The last approved version of this historical standard is referenced on www.astm.org.

The CBR is expressed as the ratio of the unit load on the piston required to penetrate 0.1 in. (2.5 mm) and 0.2 in (5.1 mm) of the test material to the unit load required to penetrate a standard material of well-graded crushed stone.

4.2 This test method is used to determine the CBR of a material compacted in a specified mold. It is incumbent on the requesting client to specify the scope of testing to satisfy the client’s protocol or specific design requirements. Possible scope of testing includes:

4.2.1 CBR penetration tests can be performed on each point of a compaction test performed in accordance with Method C of **D698** or **D1557**. The CBR mold with the spacer disk specified in this standard has the same internal dimensions as a 6.000-in. (152.4-mm) diameter compaction mold.

4.2.2 Another alternative is for the CBR test to be performed on material compacted to a specific water content and density. Alternatively, a water content range may be stated for one or more density values and will often require a series of specimens prepared using two or three compactive efforts for the specified water content contents or over the range of water contents requested. The compactive efforts are achieved by following procedures of **D698** or **D1557** but varying the blows per layer to produce densities above and below the desired density.

5. Significance and Use

5.1 This test method is used to evaluate the potential strength of subgrade, subbase, and base course materials, including recycled materials for use in the design of road and airfield pavements. The CBR value obtained in this test forms an integral part of several flexible pavement design methods.

5.2 For applications where the effect of compaction water content on CBR is small, such as cohesionless, coarse-grained materials, or where an allowance is made for the effect of differing compaction water contents in the design procedure, the CBR may be determined at the optimum water content of a specified compaction effort. The specified dry unit weight is normally the minimum percent compaction allowed by the using client’s field compaction specification.

5.3 For applications where the effect of compaction water content on CBR is unknown or where it is desired to account for its effect, the CBR is determined for a range of water contents, usually the range of water content permitted for field compaction by using the client’s protocol or specification for field compaction.

5.4 The criteria for test specimen preparation of self-cementing (and other) materials which gain strength with time must be based on a geotechnical engineering evaluation. As directed by the client, self-cementing materials shall be properly cured until bearing ratios representing long term service conditions can be measured.

NOTE 1—The quality of the results produced by this standard is dependent on the competence of the personnel performing it, and the suitability of the equipment and facilities used. Agencies that meet the criteria of Practice **D3740** are generally considered capable of competent and objective testing/sampling/inspection/etc. Users of this standard are cautioned that compliance with Practice **D3740** does not in itself ensure reliable results. Reliable results depend on many factors; Practice **D3740** provides a means of evaluating some of those factors.

6. Apparatus

6.1 *Loading Machine*—The loading machine shall be equipped with a movable head or base that travels at a uniform (not pulsating) rate of 0.05 in. (1.3 mm)/min for use in pushing the penetration piston into the specimen. The load rate of 0.05 in. (1.3 mm)/min shall be maintained within $\pm 20\%$ over the range of loads developed during penetration. The minimum capacity of the loading machine shall be based on the requirements indicated in **Table 1**.

6.1.1 The machine shall be equipped with a load-indicating device matched to the anticipated maximum penetration load. The load-indicating device shall have a minimum accuracy of: 10 lbf (44 N) or less for a 10,000 lbf (44 kN) capacity; 5 lbf (~~20~~22 N) or less for 5,000 lbf (22 kN) and 2 lbf (9 N) or less for 2,500 lbf (11 kN).

6.2 *Penetration Measuring Device*—The penetration measuring device (such as a mechanical dial indicator or electronic displacement transducer) shall be capable of reading to the nearest 0.001 in. (0.025 mm) and provided with appropriate mounting hardware. The mounting assembly of the deformation measuring device shall be connected to the penetrating piston and the edge of the mold providing accurate penetration measurements. Mounting the deformation holder assembly to a stressed component of the load frame (such as tie rods) will introduce inaccuracies of penetration measurements.

TABLE 1 Minimum Load Capacity

Maximum Measurable CBR	Minimum Load Capacity	
	(lbf)	(kN)
20	2500	11.2
50	5000	22.3
50	5,000	22.3
>50	10,000	44.5
>50	10,000	44.5

TABLE 2 SI Equivalents for Figs. Figs. 1-5-1 and 2

Inch-Pound Units, in.	SI Equivalent, mm	Inch-Pound Units, in.	SI Equivalent, mm	Inch-Pound Units, in.	SI Equivalent, mm
1.954	49.63	1¼	31.8	4½	114.3
2.416	61.37	1⅝	34.90	4¾	120.7
⅜	1.59	1½	38.1	5⅞	149.2
¼	6.4	1¾	44.5	5⅞	150.8
⅜	9.53	1⅞	28.58	6.000	152.4
7/16	11.11	2	50.8	67/32	158.0
½	12.70	2⅛	53.98	7.000	177.8
5/8	15.9	2¾	69.85	7½	190.5
¾	19.1	3	76.20	8⅞	212.7
1⅛	28.58	4¼	108.0	9⅞	238.1

Inch-Pound Units, lb	SI Equivalent, kg	Inch-Pound Units, psi	SI Equivalent, MPa
0.10	2.5	200	1.4
0.20	5.1	400	2.8
0.30	7.6	600	4.1
0.40	10.2	800	5.5
0.50	12.7	1000	6.9
		1200	8.3
		1400	9.7

6.3 *Mold*—The mold shall be a rigid metal cylinder with an inside diameter of 6.000 ± 0.026 in. (152.4 ± 0.66 mm) and a height of 7.000 ± 0.018 in. (177.8 ± 0.46 mm). It shall be provided with a metal extension collar at least 2.0 in. (50.8 mm) in height and a metal base plate having at least twenty eight ⅜-in. (1.59-mm) diameter holes uniformly spaced over the plate within the inside circumference of the mold. When assembled with the spacer disc placed in the bottom of the mold, the mold shall have an internal volume (excluding extension collar) of 0.0750 ± 0.0009 ft³ (2124 ± 25 cm³). A mold assembly having the minimum required features is shown in Fig. 1. A calibration procedure shall be used to confirm the actual volume of the mold with the spacer disk inserted. Suitable calibration procedures are contained in Test Methods D698 and D1557.

6.4 *Spacer Disk*—A circular metal spacer disc (see Fig. 1) having a minimum outside diameter of 5⅞ in. (150.8 mm) but no greater than will allow the spacer disc to easily slip into the mold. The spacer disc shall be 2.416 ± 0.005 in. (61.37 ± 0.13 mm) in height.

6.5 *Rammer*—A rammer as specified in either Test Methods D698 or D1557 except that if a mechanical rammer is used it must be equipped with a circular foot, and when so equipped, must provide a means for distributing the rammer blows uniformly over the surface of the soil when compacting in a 6.000-in. (152.4-mm) diameter mold. The mechanical rammer must be calibrated and adjusted in accordance with Test Methods D2168.

6.6 *Expansion-Measuring Apparatus*—An adjustable metal stem and perforated metal plate, similar in configuration to that shown in Fig. 42. The perforated plate shall be 5⅞ to 5⅞ in. (149.2 to 150.8 mm) in diameter and have at least forty-two ⅜-in. (1.59-mm) diameter holes uniformly spaced over the plate. A metal tripod to support the dial gauge for measuring the amount of swell during soaking is also required. The expansion measuring apparatus shall not weigh more than 2.8 lbf or a mass of 1.3 kg.

6.6.1 *Swell Measurement Device*—Generally mechanical dial indicators capable of reading to 0.001 in. (0.025 mm) with a range of 0.200-in. (5-mm) minimum.

6.7 *Surcharge Weights*—These “weights” are actually “masses” converted to a force. One or two annular metal weights having a total weight of 10 lbf (4.54 ± 0.05 lbf (equivalent to a mass of 4.54 ± 0.02 kg) and slotted metal weights each having a weight of 5 lbf (2.27 ± 0.05 lbf (equivalent to a mass of 2.27 ± 0.02 kg)). The annular weight shall be 5⅞ to 5⅞ in. (149.2 to 150.8 mm) in diameter and shall have a center hole of approximately 2⅛ in. (53.98 mm) (see Fig. 3).

6.8 *Penetration Piston*—A metal piston 1.954 ± 0.005 in. (49.63 ± 0.13 mm) in diameter and not less than 4 in. (101.6 mm) long (see Fig. 43).

6.9 *Balance*—A class GP5 balance meeting the requirements of Specifications D4753 for a balance of 1-g readability.

6.10 *Drying Oven*—Thermostatically controlled, preferably of a forced-draft type and capable of maintaining a uniform temperature of $230 \pm 9^\circ\text{F}$ ($110 \pm 5^\circ\text{C}$) throughout the drying chamber.

6.11 *Sieves*—¾ in. (19 mm) and No. 4 (4.75 mm), conforming to the requirements of Specification E11.

6.12 *Filter Paper*—A fast filtering, high grade hardened, low ash filter paper, 6.000 in. (152.4 mm) diameter.

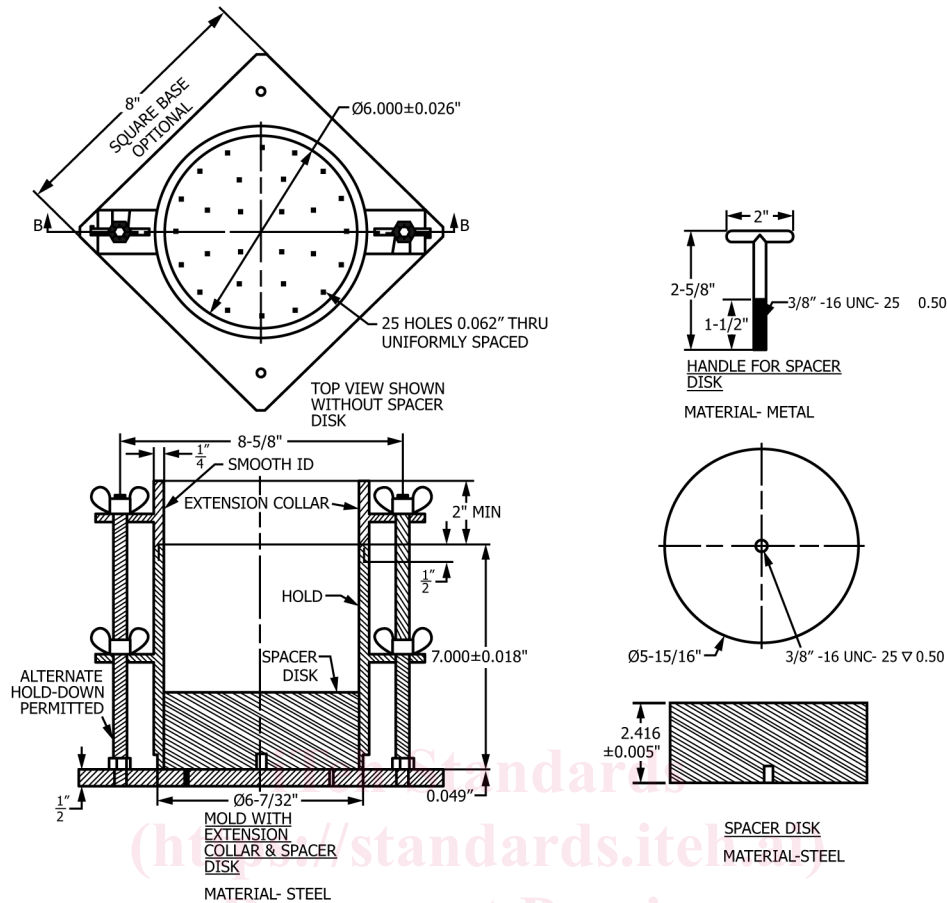

NOTE 1—See Table 2 for SI equivalents.

FIG. 1 Bearing Ratio Test Apparatus Mold with Extension Collar and Spacer Disk

6.13 *Straightedge*—A stiff metal straightedge of any convenient length but not less than 10.0 in. (254 mm). The total length of the straightedge shall be machined straight to a tolerance of ± 0.005 in. (± 0.13 mm). The scraping edge shall be beveled if it is thicker than $\frac{1}{8}$ in. (3 mm).

6.14 *Soaking Tank or Pan*—A tank or pan of sufficient depth and breath to allow free water around and over the assembled mold. The tank or pan should have a bottom grating that allows free access of water to the perforations in the mold's base.

6.15 *Mixing Tools*—Miscellaneous tools such as mixing pan, spoon, trowel, spatula, etc., or a mechanical device for thoroughly mixing the sample of soil with water.

7. Sample

7.1 The specimen(s) for compaction shall be prepared in accordance with the procedures given in Method C of Test Methods D698 or D1557 for compaction in a 6.000-in. (152.4-mm) mold except as follows:

7.1.1 If all material passes a $\frac{3}{4}$ -in. (19-mm) sieve, the entire gradation shall be used for preparing specimens for compaction without modification. If material is retained on the $\frac{3}{4}$ -in. (19-mm) sieve, the material retained on the $\frac{3}{4}$ -in. (19-mm) sieve shall be removed and replaced by an equal mass of material passing the $\frac{3}{4}$ -in. (19-mm) sieve and retained on the No. 4 (4.75 mm) sieve obtained by separation from portions of the sample not used for testing.

8. Test Specimens

8.1 *Bearing Ratio at Optimum Water Content Only*—Using material prepared as described in 7.1, conduct a control compaction test with a sufficient number of test specimens to establish the optimum water content for the soil using the compaction method specified, either Test Methods D698 or D1557. A previously performed compaction test on the same material may be substituted for the compaction test just described, provided that if the sample contains material retained on the $\frac{3}{4}$ -in. (19-mm) sieve, soil prepared as described in 7.1 is used.

NOTE 2—Maximum dry unit weight obtained from a compaction test performed in a 4.000-in. (101.6-mm) diameter mold may be slightly greater than the maximum dry unit weight obtained from compaction in the 6.000-in. (152.4-mm) compaction mold or CBR mold.

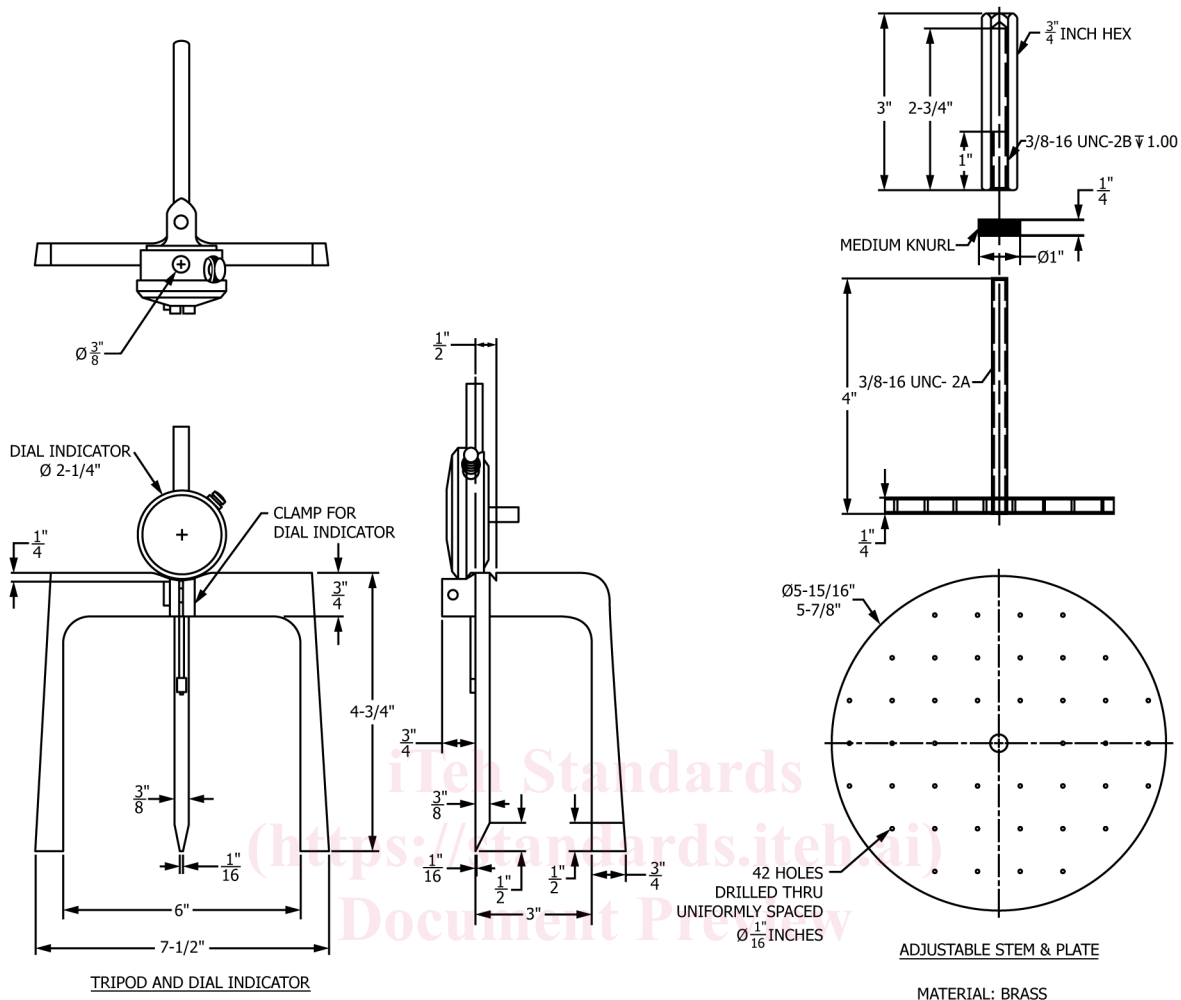

NOTE 1—See Table 2 for SI equivalents.

FIG. 2 Correction of Load-Penetration Curves Expansion-Measuring Apparatus

8.1.1 For cases where the CBR is desired at 100 % maximum dry unit weight and optimum water content, compact a specimen using the specified compaction procedure, either Test Methods D698 or D1557, from soil prepared to within ± 0.5 percentage point of optimum water content determined in accordance with Test Method D2216.

8.1.2 Where the CBR is desired at optimum water content and some percentage of maximum dry unit weight, compact three specimens from soil prepared to within ± 0.5 percentage point of optimum water content and using the specified compaction but using a different number of blows per layer for each specimen. The number of blows per layer shall be varied as necessary to prepare specimens having unit weights above and below the desired value. Typically, if the CBR for soil at 95 % of maximum dry unit weight is desired, specimens compacted using 56, 25, and 10 blows per layer is satisfactory. Penetration shall be performed on each of these specimens.

8.2 Bearing Ratio for a Range of Water Contents—Prepare specimens in a manner similar to that described in 8.1 except that each specimen used to develop the compaction curve shall be penetrated. In addition, the complete water content-unit weight relationship for the 25-blows and 10-blows per layer compactions shall be developed and each test specimen compacted shall be penetrated. Perform all compaction in the CBR mold. In cases where the specified unit weight is at or near 100 % maximum dry unit weight, it will be necessary to include a compactive effort greater than 56-blows per layer.

NOTE 3—Where the maximum dry unit weight was determined from compaction in the 4-in. (101.6-mm) mold, it may be necessary to compact specimens as described in 8.1.2, using 75 blows per layer or some other value sufficient to produce a specimen having a unit weight equal to or greater than that required.

NOTE 4—A semilog log plot of dry unit weight versus compactive effort usually gives a straight line relationship when compactive effort in ft-lb/ft³ is plotted on the log scale. This type of plot is useful in establishing the compactive effort and number of blows per layer needed to bracket the specified dry unit weight and water content range.

8.2.1 Take a representative sample of the material before it is soaked for the determination of water content to the nearest 0.1 % in accordance with Test Method D2216. If the compaction process is conducted under a controlled temperature range, 65 to 75°F