



Standard Specification for Paintball Valve Male Threaded Connection for Use with Approved Cylinders¹

This standard is issued under the fixed designation F2653; the number immediately following the designation indicates the year of original adoption or, in the case of revision, the year of last revision. A number in parentheses indicates the year of last reapproval. A superscript epsilon (ϵ) indicates an editorial change since the last revision or reapproval.

1. Scope

1.1 This specification covers the male threaded connection used to connect a CO₂ Control Valve or Compressed Air Gas Regulator with ~~an~~ a normal working output pressure of 10 342 kPa (1800 psig) or less for use with a paintball marker to a DOT approved cylinder.

1.2 The values stated in SI units are to be regarded as standard. The values given in parentheses are for information only.

1.3 *This standard does not purport to address all of the safety concerns, if any, associated with its use. It is the responsibility of the user of this standard to establish appropriate safety and health practices and determine the applicability of regulatory limitations prior to use.*

2. Referenced Documents

2.1 *ASTM Standards:*²

D2240 Test Method for Rubber Property—Durometer Hardness

F1750 Specification for Paintball Marker Threaded-Propellant Source Interface

F2030 Specification for Paintball Cylinder Burst Disk Assemblies

2.2 *Military Standards:*³

AMS7277 O-Ring Dash Sizes

MS28775 Packing, Preformed, Hydraulic, +275 Deg. F (“O”-Ring)

2.3 *CGA Standards:*⁴

CGA S-1.1 Pressure Relief Device Standards-Part 1-Cylinders for Compressed Gases

2.4 *Federal Standards:*⁵

FED-STD-H28/9A 24 March 1989 Federal Standard Screw-Thread Standards for Federal Services Section 9 Gas Cylinder Valve Outlet and Inlet Threads

NBS Handbook H-28

2.5 *Code of Federal Regulations:*⁶

DOT 49 CFR 173

DOT 49 CFR 178

DOT CFFC 4th Revision

2.6 *ANSI Standards:*⁷

ANSI Y14.5M-1994 Dimensioning and Tolerancing

3. Connector Gender Assignment

3.1 The male connector is that connector which is configured as part of the CO₂ control valve or compressed air gas regulator for use with a paintball marker.

¹ This specification is under the jurisdiction of ASTM Committee F08 on Sports Equipment, Playing Surfaces, and Facilities and is the direct responsibility of Subcommittee F08.24 on Paintball and Equipment.

Current edition approved April 1, 2015 April 1, 2016. Published August 2015 April 2016. Originally approved in 2007. Last previous edition approved in 2011 as F2653 – 11; F2653 – 11 (2015). DOI: 10.1520/F2653-11R15.10.1520/F2653-16.

² For referenced ASTM standards, visit the ASTM website, www.astm.org, or contact ASTM Customer Service at service@astm.org. For *Annual Book of ASTM Standards* volume information, refer to the standard's Document Summary page on the ASTM website.

³ Available from Standardization Documents Order Desk, DODSSP, Bldg. 4, Section D, 700 Robbins Ave., Philadelphia, PA 19111-5098, http://www.dodssp.daps.mil.

⁴ Available from Compressed Gas Association (CGA), 4221 Walney Rd., 5th Floor, Chantilly, VA 20151-2923, http://www.cganet.com.

⁵ Available from The National Conference on Weights and Measures, 15245 Shady Grove Road, Suite 130, Rockville, MD 20850.

⁶ Available from U.S. Department of Transportation, 400 7th Street, SW, Washington, D.C. 20590.

⁷ Available from American National Standards Institute (ANSI), 25 W. 43rd St., 4th Floor, New York, NY 10036, http://www.ansi.org.

3.2 The female connector is that connector which is configured as part of the DOT approved cylinder.

4. Materials and Manufacture

4.1 The male connector shall be made from materials that are compatible with CO₂, compressed air or gaseous nitrogen.

4.2 The O-ring seal shall be made from an elastomer compatible with CO₂, compressed air or gaseous nitrogen used to power paintball markers. The O-ring seal shall have a hardness that will register a Type A durometer reading of between 70 to 90 ± 5. The O-ring shall conform dimensionally to the requirements in AMS7277 or MS28775 based upon the size and material recommendations of the cylinder manufacturer.

4.3 The O-ring seal shall be installed on the male connector in the groove described by Dimensions C and D on Fig. 1.

4.4 The male connectors shall not have any sharp edges or hanging burrs. All sharp edges will be broken R.38 MAX (R.015 MAX).

4.5 The male connector shall have a gas passage allowing the contents of the bottle to flow at a rate not less than 170 sL/min at 689 kPa (6 S.C.F.M. at 100 psid).

4.6 This male connector is most commonly used in paintball marker propellant applications in conjunction with Specification F1750.

5. Performance Requirements

5.1 The male threaded connector is intended for use with CO₂, compressed air, or gaseous nitrogen, or a combination thereof.

5.2 The male threaded connector shall have a straight thread with at least the number of engaged threads as shown in Table 1, a tight fit and a factor of safety in shear of at least 10 at the test pressure of the cylinder. The test pressure for a cylinder is specified in DOT 49 CFR 178 or DOT CFFC 4th Revision. Shear stress must be calculated by using the appropriate thread shear area in accordance with NBS Handbook H-28.

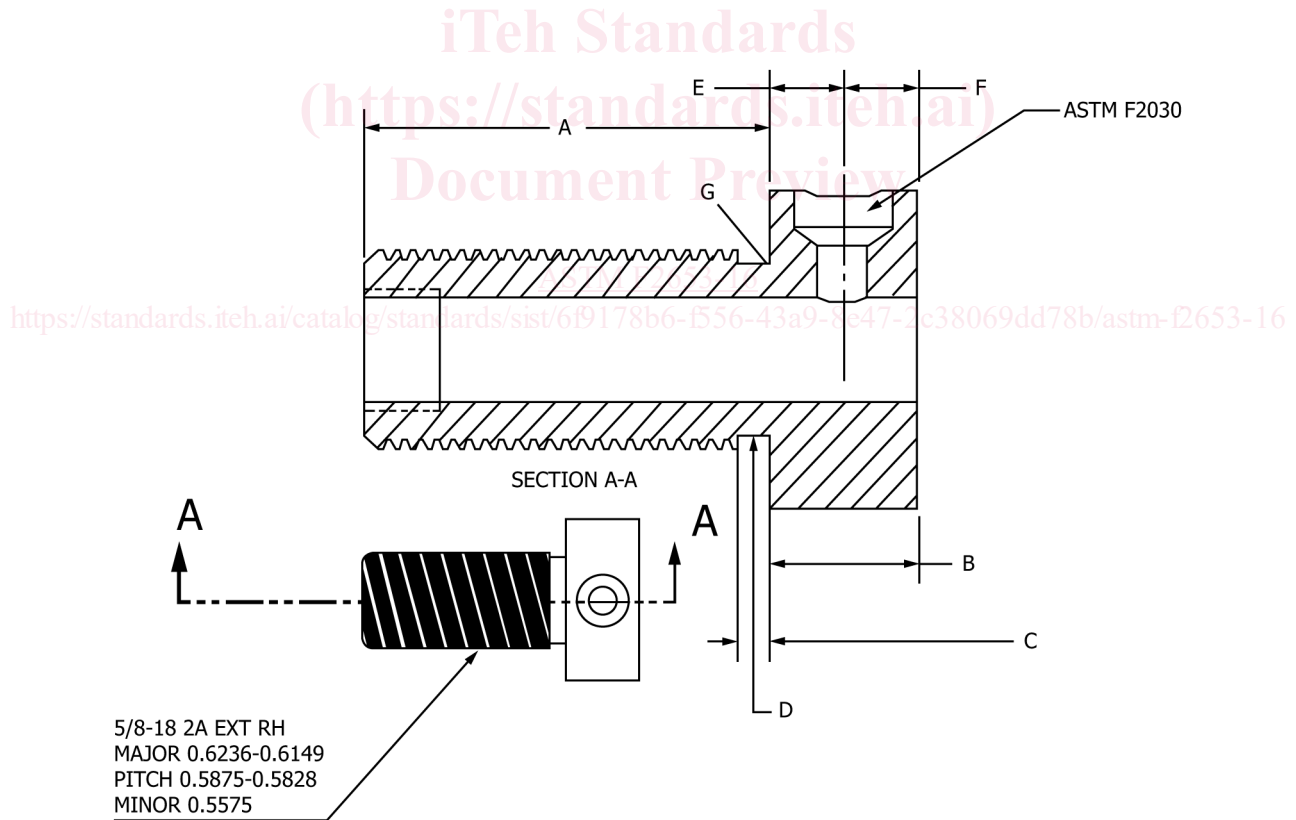

Dimension	SI	Inches
A	See Table 1	See Table 1
B	11.11 min	0.438 min
C	2.54 min	0.100 max
D	14.05 min	0.535 min
E	5.56 min	0.219 min
G	R0.7925 min	R0.0310 min

FIG. 1 Male Connector