



Designation: F1306 – 16

Standard Test Method for Slow Rate Penetration Resistance of Flexible Barrier Films and Laminates¹

This standard is issued under the fixed designation F1306; the number immediately following the designation indicates the year of original adoption or, in the case of revision, the year of last revision. A number in parentheses indicates the year of last reapproval. A superscript epsilon (ϵ) indicates an editorial change since the last revision or reapproval.

1. Scope

1.1 This test method permits flexible barrier films and laminates to be characterized for slow rate penetration resistance to a driven probe. The test is performed at room temperature, by applying a biaxial stress at a single test velocity on the material until perforation occurs. The force, energy, and elongation to perforation are determined.

1.2 The values stated in SI units are to be regarded as standard. The values given in parentheses are mathematical conversions to inch-pound units that are provided for information only and are not considered standard.

1.3 *This standard does not purport to address all of the safety concerns, if any, associated with its use. It is the responsibility of the user of this standard to establish appropriate safety and health practices and determine the applicability of regulatory limitations prior to use.*

2. Referenced Documents

2.1 *ASTM Standards:*²

D374 Test Methods for Thickness of Solid Electrical Insulation (Metric) D0374_D0374M

D618 Practice for Conditioning Plastics for Testing

D638 Test Method for Tensile Properties of Plastics

E691 Practice for Conducting an Interlaboratory Study to Determine the Precision of a Test Method

3. Terminology

3.1 *Definitions of Terms Specific to This Standard:*

3.1.1 *elongation (stretch)*—the elastic/plastic deformation of flexible sheet material under penetration by a driven probe.

¹ This test method is under the jurisdiction of ASTM Committee F02 on Primary Barrier Packaging and is the direct responsibility of Subcommittee F02.20 on Physical Properties.

Current edition approved March 1, 2016. Published April 2016. Originally approved in 1990. Last previous edition approved in 2008 as F1306 – 90(2008) ^{ϵ 1}. DOI: 10.1520/F1306-16.

² For referenced ASTM standards, visit the ASTM website, www.astm.org, or contact ASTM Customer Service at service@astm.org. For *Annual Book of ASTM Standards* volume information, refer to the standard's Document Summary page on the ASTM website.

3.1.2 *penetration resistance*—the ability of a flexible sheet material to withstand elongation and/or puncture by a driven probe.

3.1.3 *perforation*—the development of a measurable flaw through a barrier film undergoing penetration.

3.1.4 *probe penetration to failure*—distance probe travels from film contact to an instantaneous drop in load as observed on Universal Testing Equipment recorder.

3.1.5 *puncture*—the brittle elastic fracture of a flexible sheet material under penetration by a driven probe.

4. Significance and Use

4.1 Penetration resistance is an important end-use performance of thin flexible materials where a sharp-edged product can destroy the integrity of a barrier wrap. This will permit package entry/exit of gases, odors, and unwanted contaminants, causing potential harm to the product and reducing shelf-life. Material response to penetration will vary with numerous factors, such as film thickness, elastic modulus, rate of penetration, temperature, shape and type of probe. Consequently, material responses from puncture to stretch may be observed and quantified using this method. Although numerous combinations of experimental factors can be devised and used to simulate specific end-use applications, the recommended conditions in this method should be followed for standard comparisons of materials.

5. Apparatus

5.1 *Universal Testing Apparatus*, with a recording device.

5.2 *Compression Load Cell(s)*.

5.3 *Penetration Probe*, as per Fig. 1.

5.3.1 A 3.2 mm (0.125 in.) diameter hemispherical (biaxial stress) probe is recommended for general application and standard comparison of materials and interlaboratory results.

5.4 *Specimen Clamping Fixture*, as per Fig. 2 or equivalent.

5.4.1 A sample test diameter of 34.9 mm (1.375 in.) is required for interlaboratory comparison of results. (If other probes are used, a minimum clamp to probe diameter ratio of 10 to 1 is required.)

5.5 *Specimen Cutter*.

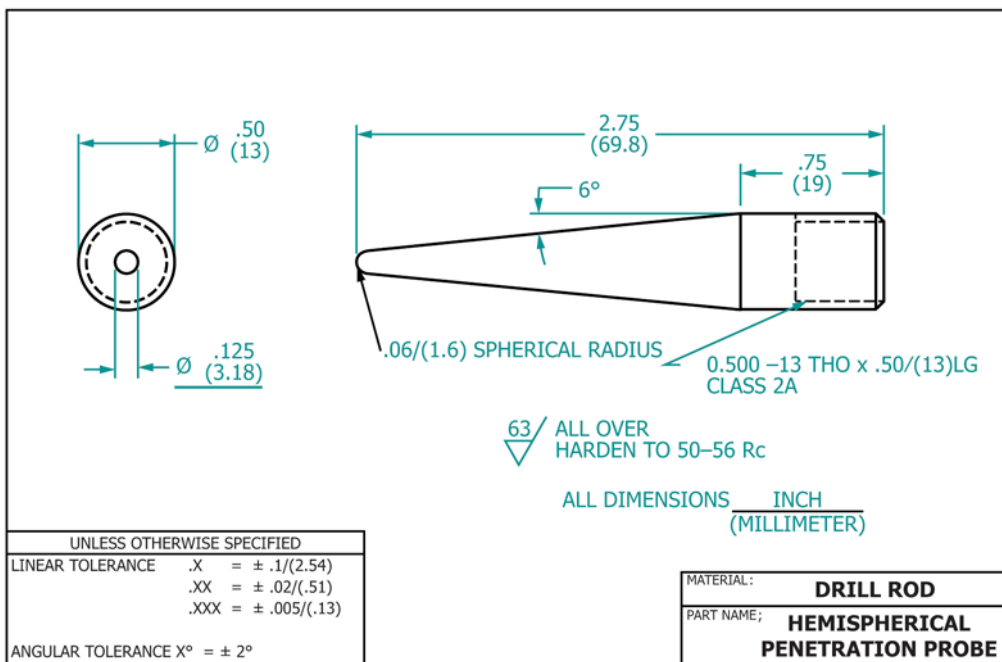

FIG. 1 Penetration Probe

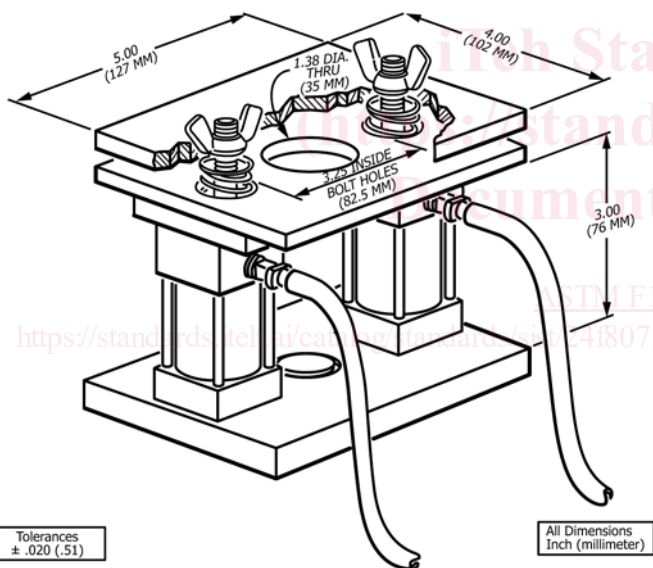

FIG. 2 Specimen Clamping Fixture

6. Test Specimen

6.1 The test specimen shall be of uniform thickness ($\pm 2\%$ or 0.0025 mm (0.0001 in.), whichever is larger).

6.2 The dimensions of the test specimen shall be 76 mm by 76 mm (3 in. by 3 in.).

7. Preparation of Apparatus

7.1 Consult the equipment operations manual for instructions to set up and operate the equipment.

7.2 Install probe apparatus.

7.3 Center probe over the fixture.

8. Number of Test Specimens

8.1 Test at least five specimens for each sample.

9. Conditioning

9.1 Condition the test specimens at $23 \pm 2^\circ\text{C}$ ($73.4 \pm 3.6^\circ\text{F}$) and $50 \pm 5\%$ relative humidity for not less than 40 h prior to test in accordance with Procedure A of Practice D618 for those tests where conditioning is required.

9.2 Conduct tests in the standard laboratory atmosphere of $23 \pm 2^\circ\text{C}$ ($73.4 \pm 3.6^\circ\text{F}$) and $50 \pm 5\%$ relative humidity unless otherwise specified in this test method.

10. Procedure

10.1 Following the instrument manufacturer's instructions, calibrate the test equipment.

10.2 Select an equipment load range so that specimen puncture occurs within 20 to 80 % of the same.

10.3 Using the specimen cutter, cut each sample material into a minimum of five 3 in. by 3 in. pieces.

10.4 Measure the caliper (average of 3 readings) in the center of a film specimen.

10.5 Adjust the universal tester cross head speed to 25 mm/min (1.0 in./min). (Set chart speed recorder to 500 mm/min (20 in./min), if applicable.) Select a data acquisition rate to give a minimum resolution of 0.1 mm/point of penetration.

10.6 Clamp the film specimen in the holder, place sample holder directly under crosshead probe, center and lower it as close as possible to the film specimen without making contact.

10.7 Set the appropriate stops and returns on the tester. Reset data collection devices to zero, if applicable.