



Designation: **F330**—~~10~~ **F330** — 16

Standard Test Method for Bird Impact Testing of Aerospace Transparent Enclosures¹

This standard is issued under the fixed designation F330; the number immediately following the designation indicates the year of original adoption or, in the case of revision, the year of last revision. A number in parentheses indicates the year of last reapproval. A superscript epsilon (ϵ) indicates an editorial change since the last revision or reapproval.

This standard has been approved for use by agencies of the U.S. Department of Defense.

1. Scope

1.1 This test method covers conducting bird impact tests under a standard set of conditions by firing a packaged bird at a stationary transparency mounted in a support structure.

1.2 The values stated in inch-pound units are to be regarded as standard. The values given in parentheses are mathematical conversions to SI units that are provided for information only and are not considered standard.

1.3 *This standard does not purport to address all of the safety concerns, if any, associated with its use. It is the responsibility of the user of this standard to establish appropriate safety and health practices and determine the applicability of regulatory limitations prior to use.* For specific hazard statements, see Section 8.

2. Terminology

2.1 Definitions:

2.1.1 *bird*—~~bird~~, *n*—the carcass that is used to impact the test article.

2.1.2 *bird package*—~~package~~, *n*—the bird and container that encases the bird to prevent disintegration enroute to target.

2.1.3 *gun*—~~gun~~, *n*—the device that propels the bird toward the target.

2.1.4 *sabot*—~~sabot~~, *n*—the container that is used to carry the bird package down the gun barrel.

2.1.5 *stripper*—~~stripper~~, *n*—the device that stops the sabot at the end of the gun barrel so that only the bird package impacts the test article.

2.1.6 *test article*—~~article~~, *n*—the transparency and supporting structure.

3. Summary of Test Method

3.1 This test method employs a smooth-bore bird gun that fires a chicken carcass so that it impacts a stationary aerospace transparency mounted in a supporting structure.

3.2 The specific parameters described by this test method are:

3.2.1 Bird weight and condition,

3.2.2 Bird velocity, and

3.2.3 Instrumentation.

4. Significance and Use

4.1 This test method ~~may~~^{shall} be used for: bird impact testing of aircraft crew compartment transparencies and supporting structure to verify the design; compilation of test data for use in verification of future transparency and supporting structure design and analytical methods; and comparative evaluation of materials.

5. Apparatus

5.1 *Gun*, compressed gas, conforming in principle to Fig. 1, comprising:

5.1.1 *Pressure Tank*, of capacity and working pressure as discussed in Note 1.

NOTE 1—A gun capable of propelling a 4-lb (1.81-kg) bird in excess of 650 knots (334 m/s) has a barrel 60 ft (18.3 m) long, bore of 6 in. (~~153 mm~~);

¹ This test method is under the jurisdiction of ASTM Committee F07 on Aerospace and Aircraft and is the direct responsibility of Subcommittee F07.08 on Transparent Enclosures and Materials.

Current edition approved ~~May 1, 2010~~ April 1, 2016. Published ~~June 2010~~ April 2016. Originally approved in 1979. Last previous edition approved in ~~2004~~ 2010 as F330—89 (2004):F330—10. DOI: ~~10.1520/F0330-10~~ 10.1520/F0330-16.

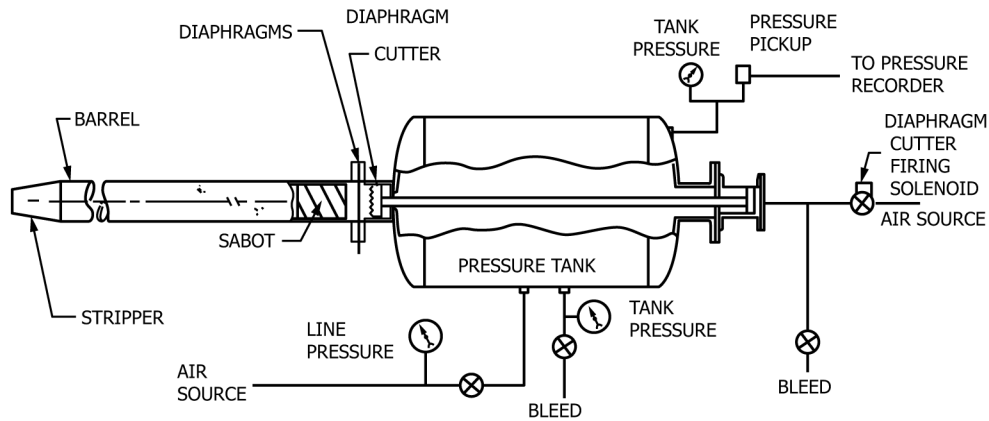

FIG. 1 Representative Air Gun

(153 mm), and a pressure tank volume of 30 ft³ (0.849 m³) with an allowable working pressure of 250 psi (1.725 × 10⁶ Pa).

5.1.2 *Release Mechanism*, comprised of a firing solenoid, diaphragm, and a cutter. Upon initiation of the firing sequence, the release mechanism allows the compressed gas stored in the pressure tank to flow rapidly into the gun barrel and propel the projectile.

NOTE 2—The most common designs normally use either one or two diaphragms in the release mechanism. In the single diaphragm design, the diaphragm is mechanically ruptured upon firing (see Fig. 1). In the dual diaphragm system, pressurized gas between the two pressurized gas diaphragms is bled to initiate firing by allowing the stored gas to burst each diaphragm in rapid succession.

5.1.3 *Barrel (Launch Tube)*, a smooth bore tube that guides the packaged bird (and sabot if used) during its acceleration by the expanding air from the pressure tank. The bore and length of the barrel is chosen both to accommodate the largest of the projectiles to be used and for the overall performance requirements of the gun.

5.1.4 *Sabot Stripper* may be typically mounted at the end of the launcher tube. The purpose of the sabot stripper is to arrest or deflect the sabot, allowing only the packaged bird to impact the test article.

5.2 Velocity Measurement System:

5.2.1 The essential features of the velocity measurement system are that it be accurate and repeatable, not be triggered by small stray objects that may be are traveling with the projectile, and not alter the flight path or damage the projectile.

5.2.2 Preferred velocity measurement systems use timing stations, located between the gun barrel and the test specimen, which are triggered by the projectiles breakage of a mechanical link “break wire” or through the interruption of a light beam. The velocity is then computed and averaged from the known distances between the timing stations. Rapid sequence photography, in conjunction with a background gridwork, may be used to provide is suitable for use as a redundant system.

NOTE 3—When using a light beam measuring system under high-humidity conditions, it is possible that the bird can become enveloped in a cloud of water droplets that could cause triggering of the light beams and the bird package shown in the film might not be clear. When using a “break wire” system, it is imperative that the tension of the wires be adjusted to within close tolerances in order to obtain consistent results.

5.3 Environmental Control:

5.3.1 The environmental control apparatus may be is used to heat or cool the test article to the desired temperature at the time of impact. The environmental control required shall be capable of providing the temperature range surrounding the test article that would critically affect the physical properties of aircraft transparencies. This range is normally -65°F (-54°C) to 250°F (121°C). The facility shall be capable of providing these temperatures for a sufficient time to achieve steady-state temperature gradients as required in the test article. A uniform source of heat or cold shall be provided; that is, no “cold” or “hot” spots shall be developed in the test article, and this shall be verified by the use of thermocouples placed at strategic points throughout the test article or by use of infrared (photography) thermographs.

5.3.2 Enclose the mounted test article and circulate preconditioned air within this enclosure, stabilize the test article at the desired test temperature, and remove the enclosure immediately before the impact test. A coolant, carbon dioxide or liquid nitrogen, may be mixed with the air to cool the air below ambient temperatures. Hot air, heat lamps, or energized electrical conductive coatings within the test article may be used to raise interior or exterior temperatures. Antiicing or Anti-icing or defogging systems, or both, may also be required. shall be used, if required by the customer.

NOTE 4—A variety of techniques have been successfully used to achieve environmental control. For example: A coolant, carbon dioxide or liquid nitrogen, is mixed with air to cool the test article below ambient temperatures. Hot air, heat lamps, or energized electrical conductive coatings within the test article are used to raise interior or exterior temperatures.

5.4 Test Instrumentation:

5.4.1 *Weight Measurement*—The weight scale shall have an accuracy of at least 0.063 oz (1.8 g).

5.4.2 *Mounting Angle Measurements (Pitch, Roll and Yaw)*—The instrument for measuring the angle, at which the test article or its support structure is mounted, shall have an accuracy of ¼ ° (0.004 36 radian).

5.4.3 *Temperature Measurement*—The instrument system for measuring temperatures shall have an accuracy of ±5°F (2.8°C).

5.4.4 *Velocity Measurement*—The instrumentation used with the velocity measurement system shall provide for an overall system accuracy within ±2 %.

5.4.5 *Rapid Sequence*, at least one high-speed camera shall be used to provide records of the bird impacting the target. The camera lighting conditions and controlling instrumentation shall be adjusted to provide a minimum of the following camera frames per second at impact:

$$F = 1000 + 5 V \text{ or} \tag{1}$$

$$F = 1000 + 1.53 v \tag{2}$$

where:

F = exposure rate (frames per second),

V = projectile velocity (ft/s), and

v = projectile velocity (m/s)

~~Timing marks may be automatically placed~~ One technique to verify camera exposure rate during the impact sequence is to place timing marks on the film at a rate of at least 100/s and at an accuracy of at least 1 % ~~to verify the camera exposure rate during the impact sequence~~ (see **Table 1** for camera exposure rate versus impact velocity).

6. Materials

6.1 Bird:

6.1.1 The bird combined with the packaging forms the projectile that impacts the test article. If a real carcass is selected, ~~it may be either a domestic or wild bird~~ both domestic and wild birds are permitted depending on the required weight. The standard weight of the bird used in this test shall be 4 lb (1.81 kg), unless a different weight is required by the certifying authority. Use a chicken as the bird for this standard weight. Either freshly kill the bird and store in a sealed container at 60 to 80° F for up to 8 h, or refrigerate up to one day, or freeze immediately after killing for future use. For a refrigerated bird, remove the bird from refrigeration and allow it to warm for approximately 4 h (for a 4-lb bird) before use. Thaw a frozen bird carcass at normal room temperature for approximately 24 h (for a 4-lb bird) before use. The minimum internal bird temperature shall be ~~60° F (15.5° C)~~ 60°F (15.5°C) at the time of use.

6.1.2 Weigh the bird just before use. To achieve the required weight, the carcass ~~may~~ shall be either trimmed, or water (or gel containing 98 % water) ~~may~~ shall be added as long as the carcass' original weight does not change more than 10 % (see **Table 2**). Remove only portions of the bird's extremities (wings and legs) when a weight reduction is necessary.

6.2 Bird Container:

6.2.1 The bird container is used to prevent the bird from becoming damaged or grossly deformed before impacting the specimen. Construct it so as to form a cylindrical projectile and of materials that minimize its effect during impact. Materials commonly used in fabricating the bird container include nylon, cotton or polyethylene bags, cardboard cartons, and expanded shapes. The weight of the bird container shall not exceed 10 % of the total projectile weight as indicated in **Table 2** for the standard projectile weights.

6.3 Sabot:

6.3.1 The sabot is used to protect and support the packaged bird during the launching and must fit intimately with the bird package and gun barrel.

TABLE 1 Camera Exposure Rate Versus Bird Impact Velocity

V		F
Bird Impact Velocity		
ft/s	m/s	Exposure Rate (Frames/Second)
100	30.5	1500
200	61.0	2000
300	91.4	2500
400	122.0	3000
500	152.0	3500
600	183.0	4000
700	213.0	4500
800	244.0	5000
900	274.0	5500
1000	305.0	6000
1100	335.0	6500
1200	366.0	7000