



Standard Specification for Faucets, Single and Double, Compression and Self-Closing Type, Shipboard¹

This standard is issued under the fixed designation F 1245; the number immediately following the designation indicates the year of original adoption or, in the case of revision, the year of last revision. A number in parentheses indicates the year of last approval. A superscript epsilon (ϵ) indicates an editorial change since the last revision or reapproval.

1. Scope

1.1 This specification covers single- and double-compression and self-closing faucets for shipboard plumbing installations.

1.2 The values stated in inch-pound units are to be regarded as the standard. The values given in parentheses are for information only.

1.3 The following precautionary caveat pertains only to the test methods portion, Section 10, of this standard. *This standard does not purport to address all of the safety concerns, if any, associated with its use. It is the responsibility of the user of this standard to establish appropriate safety and health practices and determine the applicability of regulatory limitations prior to use.*

2. Referenced Documents

2.1 ASTM Standards:

B 62 Specification for Composition Bronze or Ounce Metal Castings²

B 584 Specification for Copper Alloy Sand Castings for General Applications²

2.2 American National Standards Institute Standard:³

B1.1 Unified Inch Screw Threads (UN and UNR Thread Form)

2.3 Federal Specifications:⁴

PPP-B-566 Boxes, Folding, Paperboard

PPP-B-585 Boxes, Wood, Wirebound

PPP-B-591 Boxes, Shipping, Fiberboard, Wood-Cleated

PPP-B-601 Boxes, Wood, Cleated-Plywood

PPP-B-621 Boxes, Wood, Nailed and Lock-Corner

PPP-B-636 Box, Shipping, Fiberboard

PPP-B-676 Boxes, Setup

QQ-N-290 Nickel Plating (Electrodeposited)

QQ-C-320 Chromium Plating (Electrodeposited)

2.4 Military Specification:⁴

MIL-P-116 Preservation, Methods of

2.5 *Military Standards:*⁴

MIL-STD-105 Sampling Procedures and Tables for Inspection by Attributes

MIL-STD-129 Marking for Shipment and Storage

2.6 *Naval Sea Systems Command (NAVSEA):*⁴

NAVSEA Drawing 803-5959206 Faucet, Metering

NAVSEA Drawing 805-1623970 Unit, Lavatory for Officers Station

3. Classification

3.1 Faucets shall be of the following types and classes as specified (see 4.1):

3.1.1 *Type I*—Standard (bibb):

3.1.1.1 *Class A*—Compression, plain end.

3.1.1.2 *Class B*—Compression, hose end.

3.1.1.3 *Class C*—Self-closing.

3.1.2 *Type II*—Lavatory, self-closing, low spout.

3.1.2.1 *Class A*—Fast-closing.

3.1.2.2 *Class B*—Slow-closing, depression type.

3.1.3 *Type III*—Folding lavatory, self-closing.

3.1.4 *Type IV*—Elbow operated.

3.1.5 *Type V*—Lavatory, combination water supply and drain fixture.

3.1.6 *Type VI*—Combination supply fixture swing spout for use on galley sinks.

3.1.7 *Type VII*—Single supply fixture swing spout for use with steam kettles and urns.

3.1.7.1 *Class A*—Spout for overhead supply.

3.1.7.2 *Class B*—Spout for riser supply.

3.1.8 *Type VIII*—Supply fixture for pressed metal and shock mounted china lavatories.

3.1.9 *Type IX*—Lavatory, combination water supply and drain fixtures, depression type.

4. Ordering Information

4.1 Orders for equipment under this specification shall include the following information, as required, to describe the equipment adequately:

4.1.1 ASTM designation and year of issue,

4.1.2 Type and class of faucet required (see 3.1),

4.1.3 Type of handle required (see 6.11),

4.1.4 Marking required for handles (see 13.1),

4.1.5 Size and weight of Type I faucet required (see 7.1),

¹ This specification is under the jurisdiction of ASTM Committee F25 on Ships and Marine Technology and is the direct responsibility of Subcommittee F25.11 on Machinery and Piping Systems.

Current edition approved Sept. 29, 1989. Published November 1989.

² *Annual Book of ASTM Standards*, Vol 02.01.

³ Available from American National Standards Institute, 25 W. 43rd St., 4th Floor, New York, NY 10036.

⁴ Available from Standardization Documents Order Desk, Bldg. 4 Section D, 700 Robbins Ave., Philadelphia, PA 19111-5094, Attn: NPODS.

- 4.1.6 Overall dimensions for Type II faucets (see 7.2),
- 4.1.7 Shank design for Type II, Class B faucets (see 6.2.3.2),
- 4.1.8 Overall dimensions and position of inlet (side or bottom) for Type III faucets (see 7.3),
- 4.1.9 Overall dimensions and whether spray is required for Type IV faucets (see 6.4.1.3 and 7.4),
- 4.1.10 Length of spout for Type VI fixtures (see 7.6.1),
- 4.1.11 Whether escutcheon plates are provided for Type VI faucets (see 6.6.3),
- 4.1.12 Whether connections are other than 1/4-in. nominal pipe size (NPS) (see 6.8.2.1),
- 4.1.13 Sample size for examination and testing (see 10.1, 10.2, and 11.1), and
- 4.1.14 Optional requirements, if any (see Supplementary Requirements S1 through S3).

5. Materials

- 5.1 Faucet bodies shall be made of bronze conforming to Specification B 62 or Specification B 584.
- 5.2 Handles shall be of commercial grade cast or forged brass or bronze.
- 5.3 Bonnets, handwheels, and nuts shall be of commercial quality brass or bronze; machine screws shall be made of commercial brass.
- 5.4 Seat washers shall be of a rubber or fiber material capable of withstanding the hydrostatic test of 10.1 and suitable for water temperature from 30 to 190°F (-1 to 88°C) without deterioration of material.
- 5.5 Springs for self-closing faucets shall be of corrosion-resisting steel, phosphor bronze, or nickel copper.

6. Requirements

- 6.1 *Type I*, standard.
 - 6.1.1 Type I faucets shall be in accordance with Fig. 1.
 - 6.1.1.1 Faucets shall have hexagon shoulders and a male threaded inlet.
 - 6.1.2 Class A faucets shall be plain; Class B shall have 3/4-in. (19-mm) hose thread. Class C shall be the same as Class A except they shall be self-closing.
- 6.2 *Type II*, lavatory, self-closing, low spout.
 - 6.2.1 Faucets shall be provided with a shank, fitted with a metal washer and locknut and with a 1/4-in. NPS tailpiece.
 - 6.2.1.1 The shank of the faucet and one end of the tailpiece shall be arranged as a ground joint union; the other end of the tailpiece shall be provided with outside threads 1/4-in. NPS.
 - 6.2.2 Class A lavatory faucets shall be in accordance with Fig. 2.

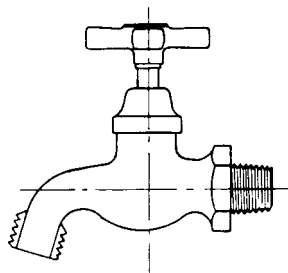
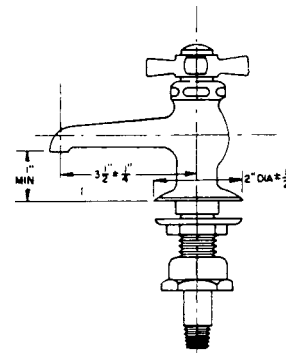
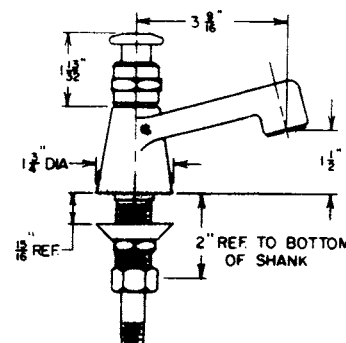

FIG. 1 Type I Standard Faucet, Classes A, B, and C



NOTE 1—All dimensions are in inches. 1 in. = 25.4 mm.
 FIG. 2 Type II Class A Lavatory, Self-Closing, Low Spout Faucet

- 6.2.2.1 They shall operate on a cam, ball, or roller bearings.
- 6.2.2.2 Faucets with renewable operating units may be used.
- 6.2.3 Class B lavatory faucets shall be in accordance with Fig. 3.
 - 6.2.3.1 They shall be fitted with an adjusting device, which cannot be tampered with, for regulating the closing from 3 to 20 s in accordance with NAVSEA Drawing 803-5959206.
 - 6.2.3.2 Shank design shall be as specified (see 4.1.7).
- 6.3 *Type III*, folding lavatory self-closing.
 - 6.3.1 Faucets shall be in accordance with Fig. 4.
 - 6.3.1.1 They shall be of the cam, ball or roller bearing self-closing type.
 - 6.3.1.2 The body shall be designed for back mounting.
- 6.4 *Type IV*, elbow operated.
 - 6.4.1 Faucets shall be in accordance with Fig. 5 except that a gooseneck spout is acceptable.
 - 6.4.1.1 They shall have a double faucet with a rigid spout with or without buttons, renewable seats, and sleeves or renewable units and integral stops in shanks with union inlets.
 - 6.4.1.2 Escutcheon plates shall be provided for the fixtures.
 - 6.4.1.3 Spray shall be provided when specified (see 4.1.9).
- 6.5 *Type V*, lavatory, combination water supply and drain fixtures.
 - 6.5.1 Fixtures shall be in accordance with Fig. 6.
 - 6.5.1.1 The trunion lugs shall be designed so that the trunions will be held in place by spring clips or other device.
- 6.6 *Type VI*, combination supply fixture swing spout for use on galley sinks.



NOTE 1—All dimensions are in inches. 1 in. = 25.4 mm.
 FIG. 3 Type II Class B Faucet

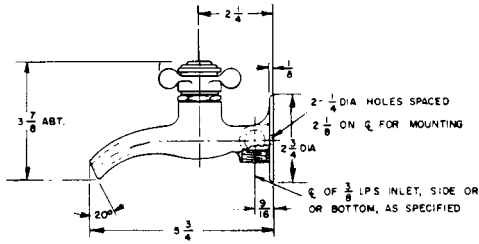

NOTE 1—All dimensions are in inches. 1 in. = 25.4 mm.
FIG. 4 Type III Folding Lavatory, Self-Closing Faucet

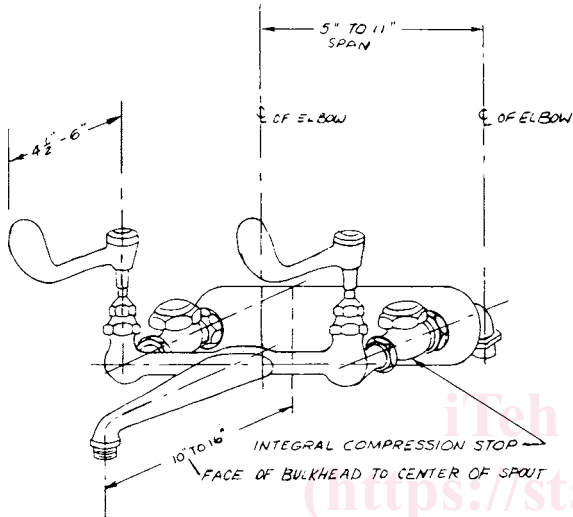

NOTE 1—All dimensions are in inches. 1 in. = 25.4 mm.
FIG. 5 Type IV Elbow-Operated Faucet

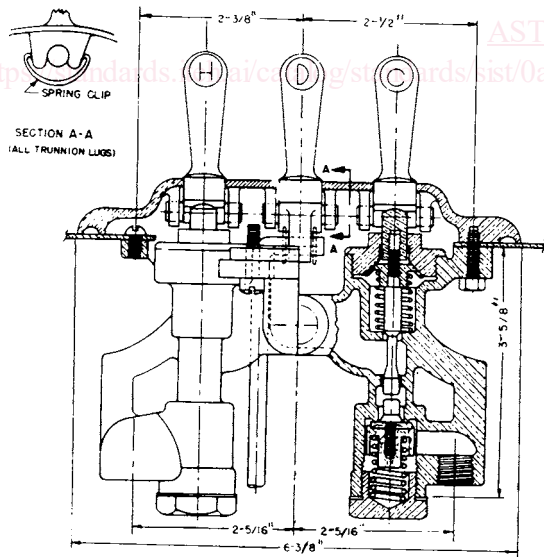

NOTE 1—All dimensions are in inches. 1 in. = 25.4 mm.
FIG. 6 Type V Faucet, Lavatory Combination Water Supply and Drain Fixture (Not for Use on New Construction)

6.6.1 Fixtures shall be in accordance with Fig. 7.
 6.6.2 Fixtures shall have manifolded hot and cold compression type faucets, discharging through a common swing spout.

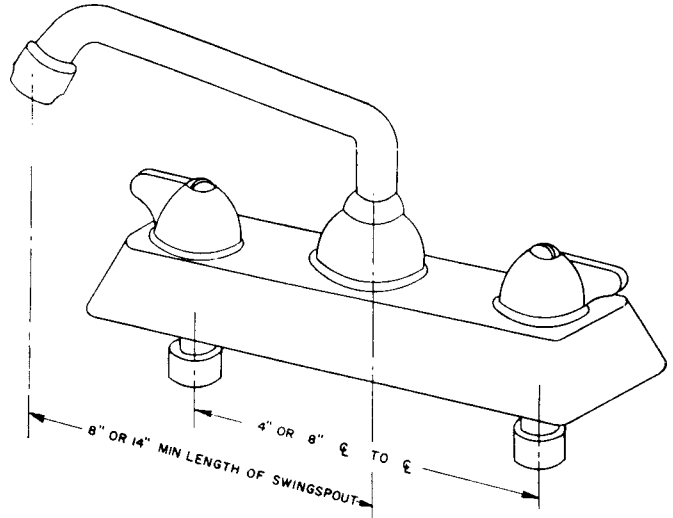

NOTE 1—All dimensions are in inches. 1 in. = 25.4 mm.
FIG. 7 Type VI Faucet, Combination Supply Fixture Swing Spout for Use on Galley Sinks

6.6.2.1 The swing joint shall be of rugged design and packed with material resistant to water and leakage at temperatures of 30 to 200°F (-1 to 93°F).

6.6.3 The faucets shall have renewable seats, sleeves, or renewable units and steps in the body and shanks with union inlet connection, with or without escutcheon plates as specified (see 4.1.11).

6.7 Type VII, single-supply fixture swing spouts for use with steam kettles and urns.

6.7.1 Fixtures shall be in accordance with Fig. 8.

6.7.1.1 They shall consist of a single-globe-type valve with NPS threaded inlet and outlet and an adaptor designed to receive a swing spout.

6.7.1.2 The swing joint shall be ruggedly constructed and fitted with packing material resistant to leakage and water at temperatures of 30 to 200°F (-1 to 93°C).

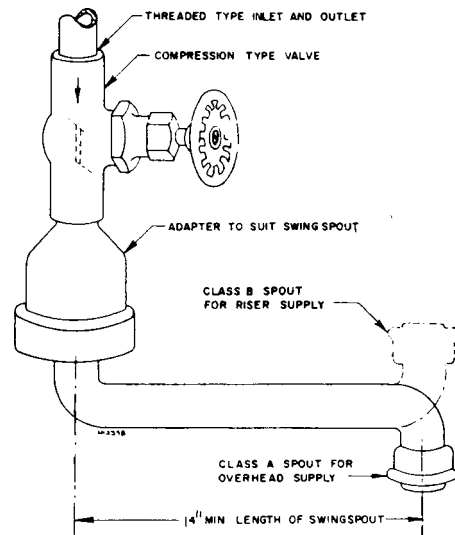

NOTE 1—All dimensions are in inches. 1 in. = 25.4 mm.
FIG. 8 Type VII Faucet, Single-Supply Fixture Swing Spout for Use with Steam Kettles and Urns