



Designation: F 1264 – 01

## Standard Specification and Test Methods for Intramedullary Fixation Devices<sup>1</sup>

This standard is issued under the fixed designation F 1264; the number immediately following the designation indicates the year of original adoption or, in the case of revision, the year of last revision. A number in parentheses indicates the year of last reapproval. A superscript epsilon ( $\epsilon$ ) indicates an editorial change since the last revision or reapproval.

### 1. Scope

1.1 This specification is intended to provide a characterization of the design and mechanical function of intramedullary fixation devices (IMFDs) specify labeling and material requirements, provide test methods for characterization of IMFD mechanical properties and identify needs for further development of test methods and performance criteria. The ultimate goal is to develop a standard which defines performance criteria and methods for measurement of performance-related mechanical characteristics of IMFDs and their fixation to bone. It is not the intention of this specification to define levels of performance or case-specific clinical performance of these devices, as insufficient knowledge is available to predict the consequences of the use of any of these devices in individual patients for specific activities of daily living. It is not the intention of this specification to describe or specify specific designs for IMFDs.

1.2 This specification describes IMFDs for surgical fixation of the skeletal system. It provides basic IFMD geometrical definitions, dimensions, classification, and terminology; labeling and material specifications; performance definitions; test methods and characteristics determined to be important to in-vivo performance of the device.

1.3 This specification includes four standard test methods:

1.3.1 Static Four-Point Bend Test Method—Annex A1 and

1.3.2 Static Torsion Test Method—Annex A2.

1.3.3 Bending Fatigue Test Method—Annex A3.

1.3.4 Test Method for Bending Fatigue of IMFD Locking Screws—Annex A4.

1.4 A rationale is given in Appendix X1.

1.5 The values stated in SI units are to be regarded as the standard.

### 2. Referenced Documents

2.1 *ASTM Standards:*

A 214/A 214M Specification for Electric-Resistance-Welded Carbon Steel Heat-Exchanger and Condenser Tubes<sup>2</sup>

<sup>1</sup> This specification is under the jurisdiction of ASTM Committee F04 on Medical and Surgical Materials and Devices and is the direct responsibility of Subcommittee F04.21 on Osteosynthesis.

Current edition approved Dec. 10, 2001. Published April 2002. Originally published as F 1264 – 89. Last previous edition F 1264 – 00.

<sup>2</sup> *Annual Book of ASTM Standards*, Vol 08.01.

A 450/A 450M Specification for General Requirements for Carbon, Ferritic Alloy, and Austenitic Alloy Steel Tubes<sup>2</sup>

D 790 Test Methods for Flexural Properties of Unreinforced and Reinforced Plastics and Electrical Insulating Materials<sup>2</sup>

E 4 Practices for Force Verification of Testing Machines<sup>3</sup>

E 691 Practice for Conducting an Interlaboratory Study to Determine the Precision of a Test Method<sup>4</sup>

F 86 Practice for Surface Preparation and Marking of Metallic Surgical Implants<sup>5</sup>

F 138 Specification for Wrought 18 Chromium-14 Nickel-2.5 Molybdenum Stainless Steel Bar and Wire for Surgical Implants (UNS S31673)<sup>5</sup>

F 339 Specification for Cloverleaf Intramedullary Pins<sup>6</sup>

F 383 Practice for Static Bend and Torsion Testing of Intramedullary Rods<sup>7</sup>

F 565 Practice for Care and Handling of Orthopaedic Implants and Instruments<sup>5</sup>

F 1611 Specification for Intramedullary Reamers<sup>5</sup>

2.2 *AMS Standard:*

AMS 5050 Steel Tubing, Seamless, 0.15 Carbon, Maximum Annealed<sup>8</sup>

2.3 *SAE Standard:*

SAE J524 Seamless Low-Carbon Steel Tubing Annealed for Bending and Flaring<sup>8</sup>

### 3. Terminology

3.1 *Definitions for Geometric:*

3.1.1 *closed section, n*—any cross section perpendicular to the longitudinal axis of a solid IMFD or hollow IMFD in which there is no discontinuity of the outer wall. To orient the IMFD for testing and for insertion, the desired relationship of any irregularities, asymmetries, and so forth, to the sagittal and coronal planes should be described for the intended applications.

3.1.2 *IMFD curvature, n*—dimensions of size and locations of arcs of the curvature, or mathematical description of the curvature, or other quantitative descriptions to which the

<sup>3</sup> *Annual Book of ASTM Standards*, Vol 03.01.

<sup>4</sup> *Annual Book of ASTM Standards*, Vol 14.02.

<sup>5</sup> *Annual Book of ASTM Standards*, Vol 13.01.

<sup>6</sup> Discontinued; see *1998 Annual Book of ASTM Standards*, Vol 13.01.

<sup>7</sup> Discontinued; see *1996 Annual Book of ASTM Standards*, Vol 13.01.

<sup>8</sup> Available from the Society of Automotive Engineers, 400 Commonwealth Dr., Warrendale, PA 15096.

curvature is manufactured along with tolerances. To orient the IMFD for testing and for insertion, the desired relationship of the curvature to the sagittal and coronal planes should be described for the intended applications.

3.1.3 *IMFD diameter, n*—The diameter of the circumscribed circle, which envelops the IMFDs' cross section when measured along the IMFDs' working length. If the diameter is not constant along the working length, then the site of measurement should be indicated.

3.1.4 *IMFD length, n*—the length of a straight line between the most proximal and distal ends of the IMFD.

3.1.5 *open section, n*—any cross section perpendicular to the longitudinal axis of a hollow IMFD in which there is a discontinuity of the outer wall. To orient the IMFD for testing and insertion, the desired relationship of the discontinuity to the sagittal and coronal planes should be described for the intended applications.

3.1.6 *potential critical stress concentrator (CSC), n*—any change in section modulus, material property, discontinuity, or other feature of a design expected to cause a concentration of stress that is located in a region of the IMFD expected to be highly stressed under the normal anticipated loading conditions.

3.1.7 *working length, n*—a length of uniform cross section of the IMFD intended to obtain some type of fit to the medullary canal in the area of the diaphysis.

3.1.8 *tolerance*—the acceptable deviations from the nominal size of any dimension describing the IMFD.

### 3.2 Definitions—Mechanical/Structural:

3.2.1 *bending compliance, n*—the reciprocal of the stiffness of the IMFD under a bending load in a specified plane as defined and determined in the static four-point bend test described in Annex A1.

3.2.2 *fatigue strength at N cycles, n*—the maximum cyclic force parameter (for example, load, moment, torque, stress, and so forth) for a given load ratio, which produces device structural damage or meets some other failure criterion in no less than *N* cycles as defined and measured according to the test conducted.

3.2.3 *failure strength, n*—the force parameter (for example, load, moment, torque, stress, and so forth) required to meet the failure criteria defined and measured according to the test conducted.<sup>9</sup>

3.2.4 *yield strength, n*—the force parameter (for example, load, moment, torque, stress, and so forth) which initiates permanent deformation as defined and measured according to the test conducted.

3.2.5 *no load motion*—some devices have a degree of free motion at fixation points which allows relative motion to occur between the device and the bone with no elastic strain in the device and no (or minimal) change in load. This is termed “no load motion.”<sup>9</sup>

3.2.6 *structural stiffness, n*—the maximum slope of the elastic portion of the load-displacement curve as defined and measured according to the test conducted. For bending in a specified plane, this term is defined and determined in the static

four-point bend test described in Annex A1.

3.2.7 *ultimate strength, n*—the maximum force parameter (for example, load, moment, torque, stress, and so forth) which the structure can support defined and measured according to the test conducted.

3.2.8 *N*—a variable representing a specified number of cycles.

## 4. Classification

4.1 The following IMFDs may be used singly, multiply, and with or without attached supplemental fixation.

4.2 Types of IMFDs: solid cross section, hollow cross section (open, closed, combination).

4.3 Intended application or use for particular IMFD designs:

4.3.1 *Preferred Orientation:*

4.3.1.1 Right versus left,

4.3.1.2 Sagittal versus coronal plane,

4.3.1.3 Proximal versus distal, and

4.3.1.4 Universal or multiple options.

4.3.2 *Preferred Anatomic Location:*

4.3.2.1 Specific bone,

4.3.2.2 Proximal versus distal versus midshaft, and

4.3.2.3 Universal or multiple options.

4.3.3 *Preferred Use Limited to Specific Procedures:*

4.3.3.1 Acute care of fractures,

(a) Specific types,

(b) Specific locations,

4.3.3.2 Reconstructive procedures, and

4.3.3.3 Universal or multiple options.

## 5. Material

5.1 All IMFDs are made of materials that have an ASTM International standard shall meet those requirements given in the ASTM International standards (2.1).

## 6. Performance Considerations and Test Methods

6.1 *Cross Section Dimensional Tolerances* affect matching the bone preparation instruments (that is, reamers) to the IMFD diameter, and fit the fixation of IMFDs in the bone.

6.1.1 Terminology related to sizing of IMFD devices and instruments is provided in Terminology F 1611.

6.2 *Longitudinal Contour Tolerances* (along with bending compliance) affect the fit and fixation of IMFDs in the bone.<sup>8</sup>

6.3 *Fatigue Strength* affects the choice of implant in cases in which delayed healing is anticipated (that is, infected non-unions, allografts, segmental loss, multiple trauma, and so forth).

6.3.1 The fatigue strength or fatigue lives or both for IMFDs subjected to cycle bending forces shall be determined using the cyclic bending fatigue test method described in Annex A3.

6.3.2 The fatigue strength or fatigue lives or both for IMFD locking screws subjected to cyclic bending forces shall be determined using the cyclic bending fatigue test method for locking screws described in Annex A4.

6.4 *Bending Strength* affects the choice of implant in which load sharing is minimized or loading is severe or both (that is, with distal or proximal locking, subtrochanteric fractures, comminuted fracture, segmental loss, noncompliant patient, and so forth).

<sup>9</sup> No present testing standard exists related to this term for IMFDs.

6.4.1 Yield, failure, and ultimate strength for IMFDs subjected to bending in a single plane shall be determined using the static four-point bend test method described in Annex A1.

6.5 *Bending and Torsional Stiffness* may affect the type and rate of healing (primary or secondary healing) depending upon the fracture type (transverse, oblique, and so forth).

6.5.1 Bending structural stiffness for IMFDs subjected to bending in a single plane shall be determined using the static four-point bend test method described in Annex A1.

6.5.2 Torsional stiffness for IMFDs subjected to pure torsion shall be determined using the static torsion test method described in Annex A2.

6.6 *No-Load Axial and Torsional Motion Allowed in Devices Using Secondary Attached Fixation* affects degree of motion at the fracture site.<sup>9</sup>

6.7 *Extraction System*—Mechanical failures should occur in the extraction device before they occur in the IMFD—prevents need to remove IMFD without proper tools.<sup>9</sup>

**7. Marking, Packaging, Labeling, and Handling**

7.1 Dimensions of IMFDs should be designated by the standard definitions given in 3.1.

7.2 Mark IMFDs using a method specified in accordance with Practice F 86.

7.3 Use the markings on the IMFD to identify the manufacturer or distributor and mark away from the most highly stressed areas where possible.

7.4 Packaging shall be adequate to protect the IMFD during shipment.

7.5 Include the following on package labeling for IMFDs:

- 7.5.1 Manufacturer and product name,
- 7.5.2 Catalog number,
- 7.5.3 Lot or serial number,
- 7.5.4 IMFD diameter (3.1.3), and
- 7.5.5 IMFD length (3.1.4).

7.6 Care for and handle IMFDs in accordance with Practice F 565.

**8. Means for Insertion and Extraction**

8.1 For IMFDs that are to be extracted using a hook device, the following requirements apply:

8.1.1 The slot at the end of the IMFD shall have the dimensions shown in Fig. 1.

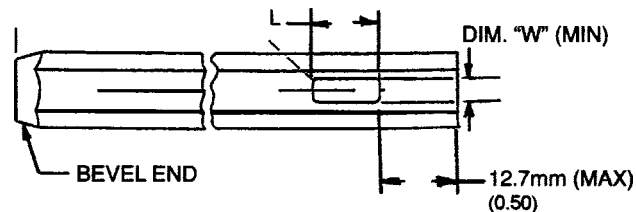

| IMFD Diameter, mm | Hook Size | Slot Length, L, mm (in.) | Slot Width, W, mm (in.) |
|-------------------|-----------|--------------------------|-------------------------|
| 6, 7              | 2         | 9.53 (0.375)             | 1.91 (0.075)            |
| 8 and larger      | 1         | 9.53 (0.375)             | 3.23 (0.127)            |

**FIG. 1 Dimensions of Extractor Hook Slot**

8.1.2 The hook used for extraction shall have the dimensions shown in Fig. 2.

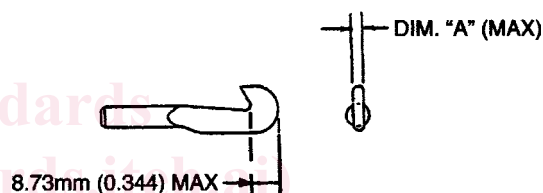

| Hook Size | Hook Width, A, mm (in.) |
|-----------|-------------------------|
| 1         | 3.05 (0.120)            |
| 2         | 1.78 (0.070)            |

**FIG. 2 Dimensions of Extractor Hook**

**9. Keywords**

9.1 bend testing; definitions; extraction; fatigue test; fracture fixation; implants; intramedullary fixation devices; orthopaedic medical device; performance; surgical devices; terminology; test methods; torsion test; trauma



## ANNEXES

### (Mandatory Information)

#### A1. TEST METHOD FOR STATIC FOUR-POINT BEND TEST METHOD

##### A1.1 Scope

A1.1.1 This test method describes methods for static four-point bend testing of intrinsic, structural properties of intramedullary fixation devices (IMFDs) for surgical fixation of the skeletal system. This test method includes bend testing in a variety of planes defined relative to the major anatomic planes. The purpose is to measure bending strength and bending stiffness intrinsic to the design and materials of IMFDs.

A1.1.2 This test method is designed specifically to test IMFD designs that have a well-defined working length ( $WL$ ) of uniform open or closed cross section throughout the majority of its length ( $WL \geq 10 \times$  diameter) and is to be applied to the full length of the diaphysis of a femur, tibia, humerus, radius, or ulna. This is not applicable to IMFDs that are used to fix only a short portion of the diaphysis of any of the long bones or the diaphysis of small bones such as the metacarpals, metatarsals, phalanges, and so forth.

A1.1.3 This test method is not intended to test the extrinsic properties of any IMFD, that is, the interaction of the device with bone or other biologic materials.

A1.1.4 This test method is not intended to define case-specific clinical performance of these devices, as insufficient knowledge is available to predict the consequences of the use of any of these devices in individual patients.

A1.1.5 This test method is not intended to serve as a quality assurance document, and thus, statistical sampling techniques for batches from production of IMFDs are not addressed.

A1.1.6 This test method may not be appropriate for all types of implant applications. The user is cautioned to consider the appropriateness of the method in view of the devices being tested, the material of their manufacture, and their potential applications.

A1.1.7 The values stated in SI units are to be regarded as the standard.

A1.1.8 *This standard does not purport to address all of the safety concerns, if any, associated with its use. It is the responsibility of the user of this standard to establish appropriate safety and health practices and determine the applicability of regulatory limitations prior to use.*

##### A1.2. Terminology

###### A1.2.1 Definitions:

A1.2.1.1 *bending compliance,  $n$* —the reciprocal of the stiffness of the IMFD under a bending load in a specified plane ( $1/EI_e$  for the IMFD,  $y/F$  for the system tested).

A1.2.1.2 *bending moment to failure,  $n$* —the moment required to meet predetermined failure criteria measured in accordance with A1.5.1. (Failure may be defined by permanent deformation, breakages or buckling.)

A1.2.1.3 *bending moment to yield,  $n$* —the moment which produces plastic deformation as defined by the 0.2 % strain

off-set method from the load-displacement curve.

A1.2.1.4 *bending structural stiffness,  $n$* —the resistance to bending of an IMFD tested in accordance with the procedures of A1.5.1, normalized to the cross-sectional properties of the working length without regard to the length of IMFD tested, by the calculations described in A1.5.1.8 (the effective  $EI_e$  for the region tested).

A1.2.1.5 *fixture/device compliance,  $n$* —a measurement of the combined compliance of the IMFD on the test fixture with co-aligned load-support points (such as A1.6.2). This value is dependent upon IMFD orientation, load direction and load and support spans.

A1.2.1.6 *ultimate bending moment,  $n$* —the moment at the maximum or ultimate load as measured on the load-displacement curve for any test in accordance with A1.5.1.

###### A1.2.2 Definitions of Terms Specific to This Standard:

A1.2.2.1 The testing mode shall consist of an applied compression load cycle, at a constant displacement rate, to a defined failure.

A1.2.2.2 The testing mode shall be single cycle of load applied at least three diameters of the IMFD from the nearest critical stress concentration point (CSC) unless otherwise specified or unless the CSC is a characteristic of the normal cross section in the working length.

##### A1.3 Classification

###### A1.3.1 Types of Test Covered by This Specification Are:

A1.3.1.1 Measurement of structural mechanical behavior inherent to IMFDs—intrinsic properties.

A1.3.1.2 Measurement of single-cycle elastic stiffness and strength in four-point bending.

A1.3.1.3 Measurement of a single-cycle fixture/device elastic compliance.

##### A1.4 Procedure

###### A1.4.1 Bending Test for Intrinsic Properties of the Working Length ( $WL$ ):

A1.4.1.1 Determine the spans to be used as described in A1.4.1.2 and A1.4.1.3 and set the spans,  $s$ ,  $c$ , and  $L$  within 1 % of the determined values.

A1.4.1.2 Conduct four-point bending at room atmospheric conditions as shown in Fig. A1.1 using two rolling supports spaced from 10 to 50 cm apart,  $L$ , with the span between the loading points,  $c$ , no greater than  $L/3$ . Loading points should also be of the rolling type, and the diameter of both the loading and support rollers should be between 1.0 and 2.6 cm. Choice of spans should be made based upon the guidelines given in A1.7.1.

A1.4.1.3 A recommendation for load and support spans is provided below to minimize interlaboratory variability and provide consistency with the previous ASTM standard for four-point bend testing of IMFDs. The suggested long or short



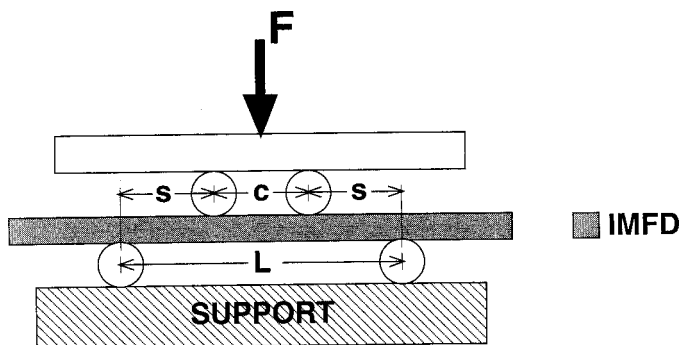

RANGE OF SPANS, in cm

L = 10 -> 50  
S = 3.3 -> 25  
c = 0 -> 16.7

**FIG. A1.1 Four-Point Bend Test Setup**

span should be used whenever possible, provided the general guidelines of A1.7.1 are achieved. The short span is identical to that used in the previous standard, Practice F 383, and the long span is based upon the experience of several laboratories testing a broad range of design and sizes of current (1995) IMFD designs.

|            |                          |                       |
|------------|--------------------------|-----------------------|
| Short span | s = c = 3.8 cm (1.5 in.) | L = 11.4 cm (4.5 in.) |
| Long span  | s = c = 7.6 cm (3.0 in.) | L = 22.8 cm (9.0 in.) |

A1.4.1.4 Apply equal loads at each of the loading points (a single load centered over the load points as shown in Figs. A1.1 and A1.2 is the usual method) at a constant rate of displacement no greater than 1 mm/s. Measure the relative deflections between the support and loading points (inner versus outer),  $y$ . For devices made of strain-rate-sensitive materials, the displacement rate for a given strain rate may be estimated by using the following approximations:

$$y_R = S_{r,1\%}, \text{ and } c = L - 2s \quad (\text{A1.1})$$

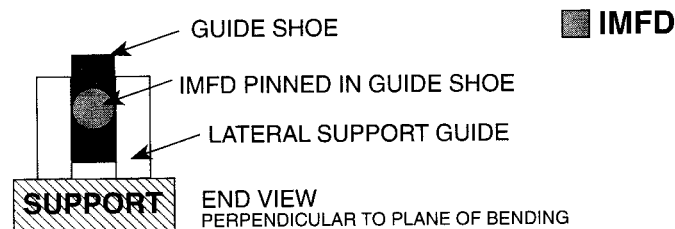
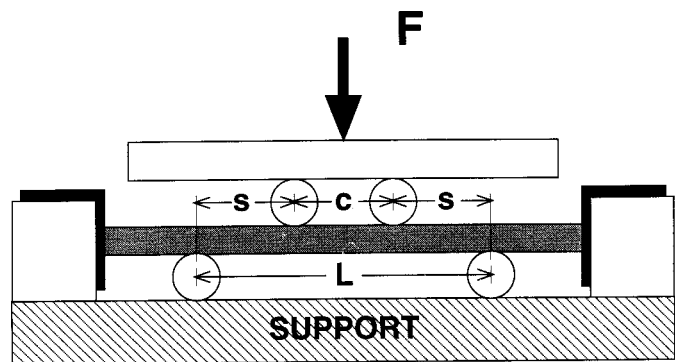

**FIG. A1.2 Four-Point Bend Test with Guide Shoes**

$$y_{1\%} = s(L + 2c)/300 D_{IMFD} \quad (\text{A1.2})$$

$$= s(3L - 4s)/300 D_{IMFD}$$

or

$$= s(sc + 2s)/300 D_{IMFD}$$

where:

- $S_r$  = the desired strain rate,
- $y_{1\%}$  = the deflection at the loading point for an estimated 1 % maximum strain in the IMFD,
- $s$  = the span from a load point to the nearest support,
- $c$  = the center span,
- $L$  = the total span ( $c + 2s$ ), and
- $D_{IMFD}$  = the diameter of the IMFD.

NOTE A1.1—The estimate of the deflection rate that corresponds to the desired strain rate is only a rough estimate based upon the assumptions of plane strain for closed-section tubes or solid rods so that the neutral axis of the cross section lies uniformly throughout the working length in the center of the circumscribed circle of the cross section and that there is material in the cross section touching the circumscribed circle where it intersects the plane of bending.

A1.4.1.5 Compute the bending moment,  $M$ , as used in A1.2.1:

$$M = Fs/2 \quad (\text{A1.3})$$

where:

- $F$  = the force applied to the system (two times the force applied to each of the loading points) and
- $s$  = the span from a load point to the nearest support.

A1.4.1.6 Compute an estimate for the maximum strain in the IMFD:

$$S_{MAX} = FS D_{IMFD} (4 EI_e)^{-1} \quad (\text{A1.4})$$

$$y = Fs^2 (L + 2c) (12 EI_e)^{-1} \quad (\text{A1.5})$$

where:

- $S_{MAX}$  = estimate of maximum strain in the IMFD,
- $F$  = force on the system,
- $s$  = span from a load point to the nearest support point,
- $EI_e$  = effective structural stiffness of the IMFD portion tested,
- $D_{IMFD}$  = diameter of the IMFD,
- $L$  = the total span between supports ( $2s + c$ ), and
- $c$  = the center span.

A1.4.1.7 Compute the bending moment to yield by estimating the load at 0.2 % maximum plastic strain. This can be approximated by calculating as follows:

$$y_{0.2\%} = s(L + 2c)/1500 D_{IMFD} \quad (\text{A1.6})$$

where:

- $y_{0.2\%}$  = the permanent deflection at the loading point for 0.2 % maximum plastic strain (estimated by measuring the offset displacement from the linear region of the load-displacement curve),
- $s$  = the span from a load point to the nearest support,
- $c$  = the center span,
- $L$  = the total span ( $c + 2s$ ), and
- $D_{IMFD}$  = the diameter of the IMFD.

At this point on the load-deflection curve, read the yield

force,  $F_y$ , from  $F_y$  the bending moment to yield is computed from:

$$M_y = F_y s / 2, \text{ (see Fig. A1.3)} \quad (A1.7)$$

Likewise, the ultimate bending moment,  $M_{MAX}$ , may be determined from the load-deflection curve:

$$M_{MAX} = F_{MAX} s / 2, \text{ (see Fig. A1.3)} \quad (A1.8)$$

NOTE A1.2—The estimate of the deflection that corresponds to the 0.2 % desired strain is only a rough estimate based upon the assumptions of plane strain for closed section tubes or solid rods so that the neutral axis of the cross section lies uniformly throughout the working length in the center of the circumscribed circle of the cross section and that there is material in the cross section touching the circumscribed circle where it intersects the plane of bending.

A1.4.1.8 Compute the bending structural stiffness:

$$EI_e = s^2(L + 2c)(F/y)/12 \quad (A1.9)$$

or

$$EI_e = s^2(3L - 4s)(F/y)/12 \quad (A1.10)$$

where:

$F/y$  = the slope of the elastic portion of the load-displacement curve,

$s$  = the span from a load point to the nearest support,

$c$  = the center span, and

$L$  = the total span ( $c + 2s$ ).

NOTE A1.3—If no linear range can be easily approximated from the load-displacement curve, the ratio of the bending load to yield, as defined in A1.2.1.1, to the total deflection produced by that load at the loading point, when tested in accordance with the procedures of A1.5.1 can be used to estimate the average slope of the elastic range of bending.

A1.4.1.9 Bending should be applied in the planes of maxi-

mum ( $I_{max}$ ) and minimum ( $I_{min}$ ) area moments of inertia of the working length cross section, and the orientation of the principal inertia axes relative to the  $ML$  and  $AP$  anatomic planes should be reported. If the working length of the IMFD does not have a uniform cross section, or is twisted such that the orientation of the principal inertial axes are not constant along its length, then the IMFD should be loaded in the  $ML$  and  $AP$  anatomic planes, with the IMFD oriented relative to the anatomic planes as defined from its intended clinical application.

A1.4.1.10 For IMFDs that have rotational instability for any given bending mode, the ends should be gripped by the fixtures shown in Fig. A1.2. This fixture will allow the IMFD to be constrained outside the actively loaded region by plates that prevent rotation of the IMFD while allowing the in-plane bending with supported, free ends in such a manner that the ends are stable when the IMFD rests on the outer support rollers. The use of guide shoes will produce a mixed loading condition as a result of friction in the portion of the system that resists rotation, that will contribute to the bending resistance. The magnitude of this effect is not easily measured or estimated but should be noted in the report.

A1.4.2 Fixture/Device Compliance Test for the Intrinsic Properties of the Working Length:

A1.4.2.1 Align both of the supports directly in line with the load points (see Fig. A1.4).

A1.4.2.2 Place the working length of the IMFD between the load point and support. Orient the IMFD so that load is applied in the desired plane ( $AP$ ,  $ML$ , or another specified direction).

A1.4.2.3 Load the IMFD in compression at a constant displacement rate of 0.1 mm/s. Record the slope of the load-displacement curve.

A1.4.2.4 Calculate the fixture/device compliance by calculating the reciprocal of the slope of the load-displacement curve in the elastic region and express in mm/N.

### A1.5 Number of Specimens

A1.5.1 At least three specimens shall be tested for each sample of IMFD of uniform working length within the test span of the same design, size, material, and so forth tested.

### A1.6 Apparatus

A1.6.1 Machines used for the bending tests should conform

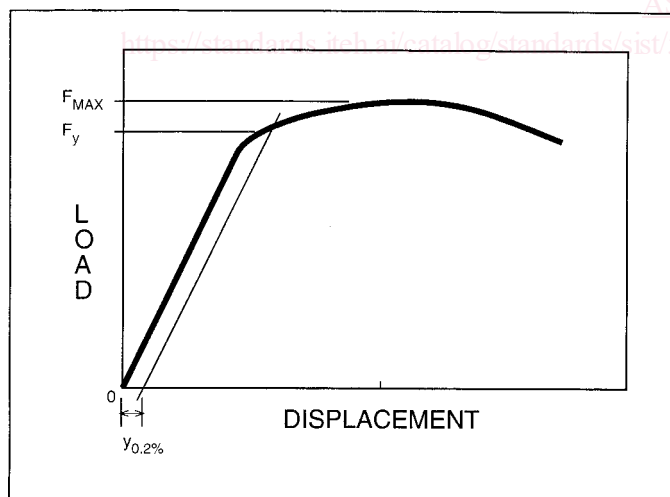

NOTE 1—An estimate of a 0.2 % yield point can be made from the “load cell versus ram displacement” measurements. Load represents the total load on the system ( $2 \times$  the load at each support) and the displacement represents the deflection at the load point(s) relative to the supports in the  $y$  (or vertical) direction. Setting  $S_{MAX} = 0.002$  in the strain estimate equation (A1.5.1.6) and substituting into  $y$  gives:

$$y_{0.2\%} = 2s(L + 2c)(3D_{IMFD})^{-1} \times 10^{-3}$$

where:  $y_{0.2\%}$  = an estimate of the deflection at the load point which corresponds to 0.2 % strain.

FIG. A1.3 Load Cell Versus Ram Displacement Graph

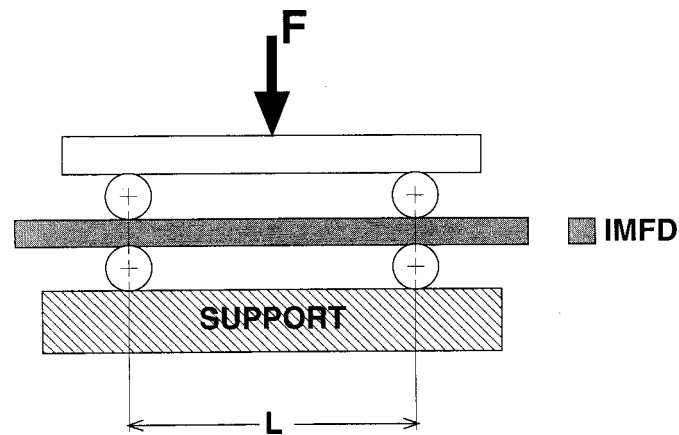

FIG. A1.4 Fixture/Device Compliance Test Setup