



Designation: **F19–11 F19 – 11 (Reapproved 2016)**

Standard Test Method for Tension and Vacuum Testing Metallized Ceramic Seals¹

This standard is issued under the fixed designation F19; the number immediately following the designation indicates the year of original adoption or, in the case of revision, the year of last revision. A number in parentheses indicates the year of last reapproval. A superscript epsilon (ϵ) indicates an editorial change since the last revision or reapproval.

1. Scope

1.1 This test method covers procedures for conducting tension and vacuum tests on metal-ceramic seals to determine the bond strength of brazed, metallized ceramics.

1.2 The values stated in inch-pound units are to be regarded as standard. The values given in parentheses are mathematical conversions to SI units that are provided for information only and are not considered standard.

1.3 *This standard does not purport to address all of the safety concerns, if any, associated with its use. It is the responsibility of the user of this standard to establish appropriate safety and health practices and determine the applicability of regulatory limitations prior to use.*

2. Referenced Documents

2.1 *ASTM Standards:*²

E4 Practices for Force Verification of Testing Machines

E6 Terminology Relating to Methods of Mechanical Testing

3. Terminology

3.1 *Definitions:*

3.1.1 The definitions of terms relating to tension testing appearing in Terminology **E6**, shall apply to the terms used in this test method.

4. Significance and Use

4.1 This test method covers procedures for conducting tension and vacuum tests on metal-ceramic seals.

4.2 This test method is not to be considered as an absolute tension test for the ceramic.

4.3 This test method is suitable for quality control and research and development use.

5. Apparatus

5.1 *Testing Machines*—Machines used for tension testing shall conform to the requirements of Methods **E4**. Only loads that are within the loading range of the testing machine, as defined in Methods **E4**, shall be used for determining tensile strengths.

5.2 *Gripping Devices*—Various types of gripping devices may be used to apply the load to the test specimen. Those shown in **Fig. 1** are recommended, but regardless of which grips are used, care shall be taken that the axis of the test specimen is in alignment with the centerline of the test machine heads.

6. Preparation of Specimens

6.1 Prepare the test specimen by brazing together two pieces of ceramic, shown in **Fig. 2**, at their respective metalized surfaces, as described in **6.1.1** to **6.1.3**:

¹ This test method is under the jurisdiction of ASTM Committee **F01** on Electronics and is the direct responsibility of Subcommittee **F01.03** on Metallic Materials, **Wire Bonding, and Flip Chip**.

Current edition approved June 1, 2011; May 1, 2016. Published July 2011; May 2016. Originally approved in 1961 as F19 – 61 T. Last previous edition approved in 2005 as F19 – 64(2005)11. [DOI: 10.1520/F0019-11](https://doi.org/10.1520/F0019-11); [DOI: 10.1520/F0019-11R16](https://doi.org/10.1520/F0019-11R16).

² For referenced ASTM standards, visit the ASTM website, www.astm.org, or contact ASTM Customer Service at service@astm.org. For *Annual Book of ASTM Standards* volume information, refer to the standard's Document Summary page on the ASTM website.

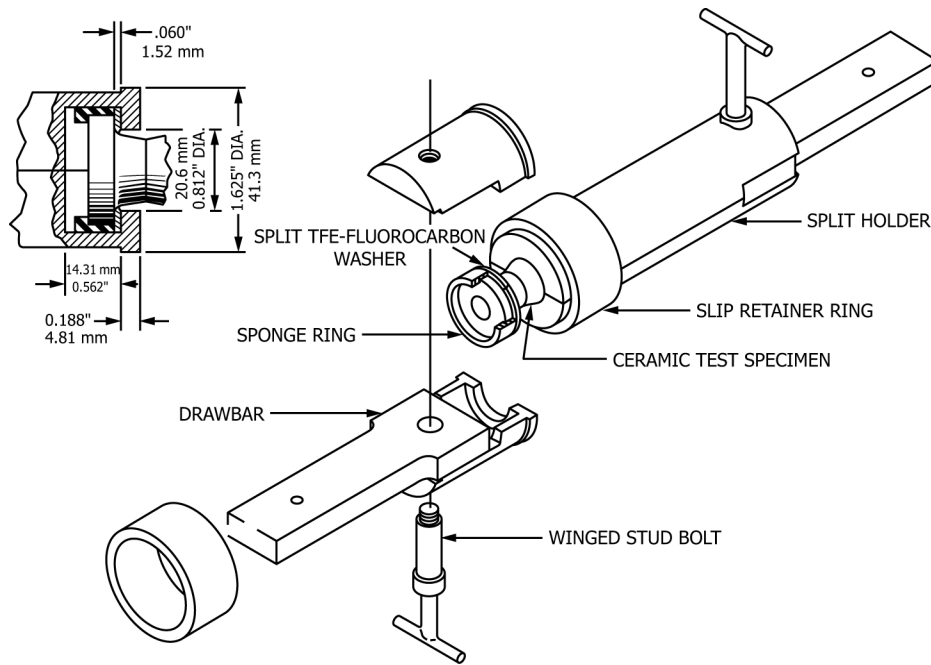

NOTE 1—Tolerance on all dimensions shown, ± 0.016 in. (0.41 mm).

FIG. 1 Self Aligning Grip for Tension Test

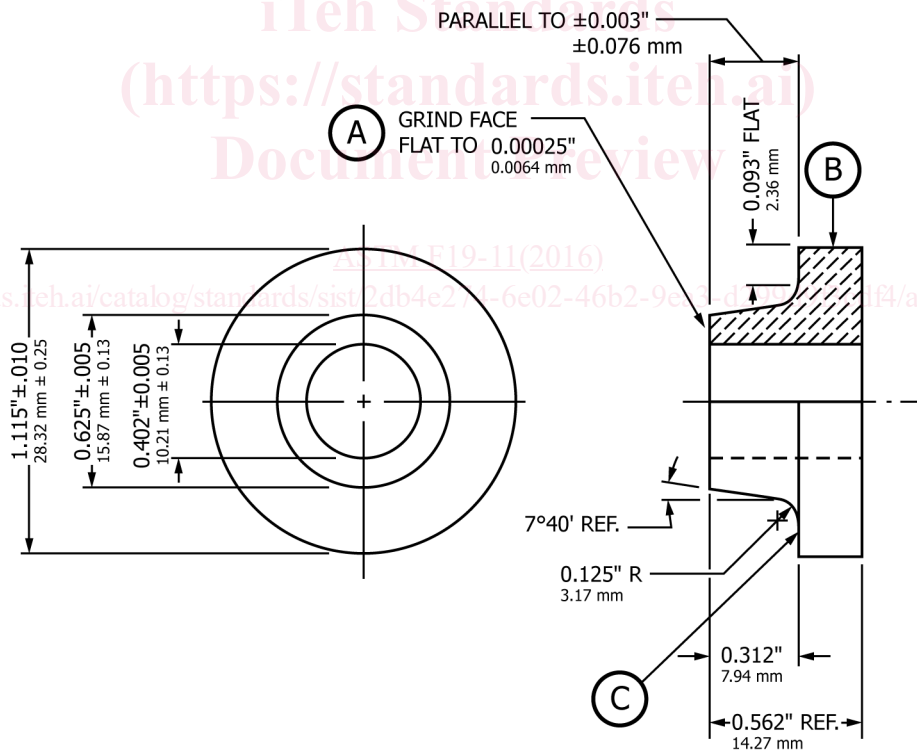

- A—Seal surface area to be metalized.
- B—Surface inscribed with date as to ceramic batch and firing temperature.
- C—Gripping shoulder.

FIG. 2 Ceramic Half of Tension Test Specimen

6.1.1 *Ceramics*—Grind the test surface, A, (Fig. 2) of the two ceramic parts flat to within 0.00025 in. (0.0064 mm) according to good grinding practice using an abrasive passing or finer than a No. 100 (150- μ m) sieve. The ground surface, A, of each part shall be parallel to shoulder C, as shown in Fig. 2, consistent with the best commercial practice. The over-all appearance of each

ceramic half of the test specimen shall indicate good commercial practice, and shall be free from obvious defects. In the results of the test, report the method of manufacture of the specimen components, that is, slip cast, hotpressed, hydrostatically molded, etc. Measure and record the test surface area of each ceramic half on a projection comparator, or by other suitable means. Dye check the two ceramic parts and inspect them for flaws (Note 1). Reject all parts showing flaws considered conducive to abnormal failures of either ceramic part.

NOTE 1—A suggested dye check procedure is described in the Appendix.

6.1.2 *Metallized Coating*—Metallize the specimen halves under identical conditions, that is, temperature, atmosphere, etc. The type of metallizing used is optional, or as mutually agreed upon between producer and consumer. Apply the metallizing coating only to the test surface A, Fig. 2, on the specimen. The method of metallizing is optional, that is, silk screen, brush, spray, roller, etc., but should be reported.

NOTE 2—A typical metallizing procedure is described in the Appendix.

6.1.3 *Assembling the Test Specimen*—Place the two mating parts in a suitable jig to achieve axial alignment of the mated ceramic halves and alignment of the metallized surfaces. Accurate alignment, which is essential to attain uniform test results, may be accomplished by jiggling with a rod of refractory material, such as ceramic or carbon (Fig. 3). Pass the rod through the assembly and then braze the specimen in a vertical position. In the test results, report the brazing material used; such as copper-silver eutectic, copper-gold alloy, 35 to 65 %, etc. Use sufficient material to produce an even fillet at the joint. Load the assembly to produce pressure on the seal during the brazing operation and report the weight of the load.

7. Procedure

7.1 *Leak Test*—The brazed test specimen may be vacuum-leak checked on any conventional helium spectrometer-type leak checker with a sensitivity of 5×10^{-9} cc/s at (5×10^{-9} mL/s) at standard temperature and pressure. Subject the specimen continuously to an atmosphere of helium for 1/2 to 5 min. The leak-checking instrument, set at maximum sensitivity, shall show no indication of a leak during the test period.

7.2 *Tension Test*— Place the specimen in the self-aligning grips with a polytetrafluoroethylene (TFE-fluorocarbon) washer between the ceramic and the jaws of the grip (see Fig. 1). Test all specimens under the same loading rate which, although optional, shall be reported.

7.3 *Other Tests*— Brazed assemblies prepared in accordance with Section 5 can also be used to:

7.3.1 Test ceramic-metal seals with a metal washer inserted between the test pieces, and

7.3.2 Perform environmental tests such as heat shock, oxidation resistance, and bakeout, to determine either the point of vacuum failure or the tensile strength at vacuum failure.

8. Calculation

8.1 Calculate the tensile strength by dividing the maximum load on the specimen during the tension test by the original cross-sectional area. Consider only those specimens that break in or near the seal area when calculating test data. Fracture of the test specimen in any other area than at or adjacent to the seal may indicate either a lack of alignment of the ceramic parts or a bond strength exceeding the range of the test specimen.

9. Report

9.1 Report the following information:

- 9.1.1 Method of manufacture of the specimen components,
- 9.1.2 Test surface area of each specimen component,
- 9.1.3 Method of metallizing specimen,
- 9.1.4 Brazing material used,
- 9.1.5 Load applied to specimen during brazing,
- 9.1.6 Results of leak test,
- 9.1.7 Loading rate of tension test,

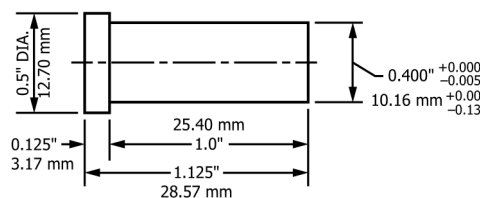

NOTE 1—Material—ACX Graphite.

FIG. 3 Alignment Jig for Brazing Tension Test Specimen