



Designation: F76 – 08 (Reapproved 2016)

Standard Test Methods for Measuring Resistivity and Hall Coefficient and Determining Hall Mobility in Single-Crystal Semiconductors¹

This standard is issued under the fixed designation F76; the number immediately following the designation indicates the year of original adoption or, in the case of revision, the year of last revision. A number in parentheses indicates the year of last reapproval. A superscript epsilon (ϵ) indicates an editorial change since the last revision or reapproval.

1. Scope

1.1 These test methods cover two procedures for measuring the resistivity and Hall coefficient of single-crystal semiconductor specimens. These test methods differ most substantially in their test specimen requirements.

1.1.1 *Test Method A, van der Pauw (1)*²—This test method requires a singly connected test specimen (without any isolated holes), homogeneous in thickness, but of *arbitrary* shape. The contacts must be sufficiently small and located at the periphery of the specimen. The measurement is most easily interpreted for an isotropic semiconductor whose conduction is dominated by a single type of carrier.

1.1.2 *Test Method B, Parallelepiped or Bridge-Type*—This test method requires a specimen homogeneous in thickness and of *specified* shape. Contact requirements are specified for both the parallelepiped and bridge geometries. These test specimen geometries are desirable for anisotropic semiconductors for which the measured parameters depend on the direction of current flow. The test method is also most easily interpreted when conduction is dominated by a single type of carrier.

1.2 These test methods do not provide procedures for shaping, cleaning, or contacting specimens; however, a procedure for verifying contact quality is given.

NOTE 1—Practice F418 covers the preparation of gallium arsenide phosphide specimens.

1.3 The method in Practice F418 does not provide an interpretation of the results in terms of basic semiconductor properties (for example, majority and minority carrier mobilities and densities). Some general guidance, applicable to certain semiconductors and temperature ranges, is provided in the Appendix. For the most part, however, the interpretation is left to the user.

¹ These test methods are under the jurisdiction of ASTM Committee F01 on Electronics and are the direct responsibility of Subcommittee F01.15 on Compound Semiconductors.

Current edition approved May 1, 2016. Published May 2016. Originally approved in 1967. Last previous edition approved in 2008 as F76 – 08. DOI: 10.1520/F0076-08R16.

² The boldface numbers in parentheses refer to the list of references at the end of these test methods.

1.4 Interlaboratory tests of these test methods (Section 19) have been conducted only over a limited range of resistivities and for the semiconductors, germanium, silicon, and gallium arsenide. However, the method is applicable to other semiconductors provided suitable specimen preparation and contacting procedures are known. The resistivity range over which the method is applicable is limited by the test specimen geometry and instrumentation sensitivity.

1.5 The values stated in acceptable metric units are to be regarded as the standard. The values given in parentheses are for information only. (See also 3.1.4.)

1.6 *This standard does not purport to address all of the safety concerns, if any, associated with its use. It is the responsibility of the user of this standard to establish appropriate safety and health practices and determine the applicability of regulatory limitations prior to use.*

2. Referenced Documents

2.1 ASTM Standards:³

D1125 Test Methods for Electrical Conductivity and Resistivity of Water

E2554 Practice for Estimating and Monitoring the Uncertainty of Test Results of a Test Method Using Control Chart Techniques

F26 Test Methods for Determining the Orientation of a Semiconductive Single Crystal (Withdrawn 2003)⁴

F43 Test Methods for Resistivity of Semiconductor Materials (Withdrawn 2003)⁴

F47 Test Method for Crystallographic Perfection of Silicon by Preferential Etch Techniques⁴

F418 Practice for Preparation of Samples of the Constant Composition Region of Epitaxial Gallium Arsenide Phosphide for Hall Effect Measurements (Withdrawn 2008)⁴

³ For referenced ASTM standards, visit the ASTM website, www.astm.org, or contact ASTM Customer Service at service@astm.org. For *Annual Book of ASTM Standards* volume information, refer to the standard's Document Summary page on the ASTM website.

⁴ The last approved version of this historical standard is referenced on www.astm.org.

2.2 SEMI Standard:
C1 Specifications for Reagents⁵

3. Terminology

3.1 Definitions:

3.1.1 *Hall coefficient*—the ratio of the Hall electric field (due to the Hall voltage) to the product of the current density and the magnetic flux density (see X1.4).

3.1.2 *Hall mobility*—the ratio of the magnitude of the Hall coefficient to the resistivity; it is readily interpreted only in a system with carriers of one charge type. (See X1.5)

3.1.3 *resistivity*—of a material, is the ratio of the potential gradient parallel to the current in the material to the current density. For the purposes of this method, the resistivity shall always be determined for the case of zero magnetic flux. (See X1.2.)

3.1.4 *units*—in these test methods SI units are not always used. For these test methods, it is convenient to measure length in centimetres and to measure magnetic flux density in gauss. This choice of units requires that magnetic flux density be expressed in $V \cdot s \cdot cm^{-2}$ where:

$$1 V \cdot s \cdot cm^{-2} = 10^8 \text{ gauss}$$

The units employed and the factors relating them are summarized in Table 1.

4. Significance and Use

4.1 In order to choose the proper material for producing semiconductor devices, knowledge of material properties such as resistivity, Hall coefficient, and Hall mobility is useful. Under certain conditions, as outlined in the Appendix, other useful quantities for materials specification, including the charge carrier density and the drift mobility, can be inferred.

5. Interferences

5.1 In making resistivity and Hall-effect measurements, spurious results can arise from a number of sources.

5.1.1 Photoconductive and photovoltaic effects can seriously influence the observed resistivity, particularly with high-resistivity material. Therefore, all determinations should be made in a dark chamber unless experience shows that the results are insensitive to ambient illumination.

5.1.2 Minority-carrier injection during the measurement can also seriously influence the observed resistivity. This interference is indicated if the contacts to the test specimen do not have linear current-versus-voltage characteristics in the range used in the measurement procedure. These effects can also be detected by repeating the measurements over several decades of current. In the absence of injection, no change in resistivity should be observed. It is recommended that the current used in the measurements be as low as possible for the required precision.

5.1.3 Semiconductors have a significant temperature coefficient of resistivity. Consequently, the temperature of the specimen should be known at the time of measurement and the current used should be small to avoid resistive heating. Resistive heating can be detected by a change in readings as a function of time starting immediately after the current is applied and any circuit time constants have settled.

5.1.4 Spurious currents can be introduced in the testing circuit when the equipment is located near high-frequency generators. If equipment is located near such sources, adequate shielding must be provided.

5.1.5 Surface leakage can be a serious problem when measurements are made on high-resistivity specimens. Surface effects can often be observed as a difference in measured value of resistivity or Hall coefficient when the surface condition of the specimen is changed (2, 3).

5.1.6 In measuring high-resistivity samples, particular attention should be paid to possible leakage paths in other parts of the circuit such as switches, connectors, wires, cables, and the like which may shunt some of the current around the sample. Since high values of lead capacitance may lengthen the time required for making measurements on high-resistivity samples, connecting cable should be as short as practicable.

5.1.7 Inhomogeneities of the carrier density, mobility, or of the magnetic flux will cause the measurements to be inaccurate. At best, the method will enable determination only of an

TABLE 1 Units of Measurement

Quantity	Symbol	SI Unit	Factor ^A	Units of Measurement ^B
Resistivity	ρ	$\Omega \cdot m$	10^2	$\Omega \cdot cm$
Charge carrier concentration	n, p	m^{-3}	10^{-6}	cm^{-3}
Charge	e, q	C	1	C
Drift mobility, Hall mobility	μ, μ_H	$m^2 \cdot V^{-1} \cdot s^{-1}$	10^4	$cm^2 \cdot V^{-1} \cdot s^{-1}$
Hall coefficient	R_H	$m^3 \cdot C^{-1}$	10^6	$cm^3 \cdot C^{-1}$
Electric field	E	$V \cdot m^{-1}$	10^{-2}	$V \cdot cm^{-1}$
Magnetic flux density	B	T	10^4	gauss
Current density	J	$A \cdot m^{-2}$	10^{-4}	$A \cdot cm^{-2}$
Length	L, t, w, d	m	10^2	cm
Potential difference	a, b, c	V	1	V

^AThe factors relate SI units to the units of measurement as in the following example:

$$1 \Omega \cdot m = 10^2 \Omega \cdot cm$$

^BThis system is not a consistent set of units. In order to obtain a consistent set, the magnetic flux density must be expressed in $V \cdot s \cdot cm^{-2}$. The proper conversion factor is:

$$1 \cdot V \cdot s \cdot cm^{-2} = 10^8 \text{ gauss}$$

undefined average resistivity or Hall coefficient. At worst, the measurements may be completely erroneous (2, 3, 4).

5.1.8 Thermomagnetic effects with the exception of the Ettingshausen effect can be eliminated by averaging of the measured transverse voltages as is specified in the measurement procedure (Sections 11 and 17). In general, the error due to the Ettingshausen effect is small and can be neglected, particularly if the sample is in good thermal contact with its surroundings (2, 3, 4).

5.1.9 For materials which are anisotropic, especially semiconductors with noncubic crystal structures, Hall measurements are affected by the orientation of the current and magnetic field with respect to the crystal axes (Appendix, Note X1.1). Errors can result if the magnetic field is not within the low-field limit (Appendix, Note X1.1).

5.1.10 Spurious voltages, which may occur in the measuring circuit, for example, thermal voltages, can be detected by measuring the voltage across the specimen with no current flowing or with the voltage leads shorted at the sample position. If there is a measurable voltage, the measuring circuit should be checked carefully and modified so that these effects are eliminated.

5.1.11 An erroneous Hall coefficient will be measured if the current and transverse electric field axes are not precisely perpendicular to the magnetic flux. The Hall coefficient will be at an extremum with respect to rotation if the specimen is properly positioned (see 7.4.4 or 13.4.4).

5.2 In addition to these interferences the following must be noted for van der Pauw specimens.

5.2.1 Errors may result in voltage measurements due to contacts of finite size. Some of these errors are discussed in references (1, 5, 6).

5.2.2 Errors may be introduced if the contacts are not placed on the specimen periphery (7).

5.3 In addition to the interferences described in 5.1, the following must be noted for parallelepiped and bridge-type specimens.

5.3.1 It is essential that in the case of parallelepiped or bridge-type specimens the Hall-coefficient measurements be made on side contacts far enough removed from the end contacts that shorting effects can be neglected (2, 3). The specimen geometries described in 15.3.1 and 15.3.2 are designed so that the reduction in Hall voltage due to this shorting effect is less than 1 %.

TEST METHOD A—FOR VAN DER PAUW SPECIMENS

6. Summary of Test Method

6.1 In this test method, specifications for a van der Pauw (1) test specimen and procedures for testing it are covered. A procedure is described for determining resistivity and Hall coefficient using direct current techniques. The Hall mobility is calculated from the measured values.

7. Apparatus

7.1 *For Measurement of Specimen Thickness*—Micrometer, dial gage, microscope (with small depth of field and calibrated

vertical-axis adjustment), or calibrated electronic thickness gage capable of measuring the specimen thickness to ± 1 %.

7.2 *Magnet*—A calibrated magnet capable of providing a magnetic flux density uniform to ± 1.0 % over the area in which the test specimen is to be located. It must be possible to reverse the direction of the magnetic flux (either electrically or by rotation of the magnet) or to rotate the test specimen 180° about its axis parallel to the current flow. Apparatus, such as an auxiliary Hall probe or nuclear magnetic resonance system, should be available for measuring the flux density to an accuracy of ± 1.0 % at the specimen position. If an electromagnet is used, provision must be made for monitoring the flux density during the measurements. Flux densities between 1000 and 10 000 gauss are frequently used; conditions governing the choice of flux density are discussed more fully elsewhere (2, 3, 4).

7.3 Instrumentation:

7.3.1 *Current Source*, capable of maintaining current through the specimen constant to ± 0.5 % during the measurement. This may consist either of a power supply or a battery, in series with a resistance greater than $200 \times$ the total specimen resistance (including contact resistance). The current source is accurate to ± 0.5 % on all ranges used in the measurement. The magnitude of current required is less than that associated with an electric field of $1 \text{ V}\cdot\text{cm}^{-1}$ in the specimen.

7.3.2 *Electrometer or Voltmeter*, with which voltage measurements can be made to an accuracy of ± 0.5 %. The current drawn by the measuring instrument during the resistivity and Hall voltage measurements shall be less than 0.1 % of the specimen current, that is, the input resistance of the electrometer (or voltmeter) must be $1000 \times$ greater than the resistance of the specimen.

7.3.3 *Switching Facilities*, used for reversal of current flow and for connecting in turn the required pairs of potential leads to the voltage-measuring device.

7.3.3.1 *Representative Circuit*, used for accomplishing the required switching is shown in Fig. 1.

7.3.3.2 *Unity-Gain Amplifiers*, used for high-resistivity semiconductors, with input impedance greater than $1000 \times$ the specimen resistance are located as close to the specimen as possible to minimize current leakage and circuit time-constants (8, 9). Triaxial cable is used between the specimen and the amplifiers with the guard shield driven by the respective amplifier output. This minimizes current leakage in the cabling. The current leakage through the insulation must be less than 0.1 % of the specimen current. Current leakage in the specimen holder must be prevented by utilizing a suitable high-resistivity insulator such as boron nitride or beryllium oxide.

7.3.3.3 *Representative Circuit*, used for measuring high-resistance specimens is shown in Fig. 2. Sixteen single-pole, single-throw, normally open, guarded reed relays are used to connect the current source and differential voltmeter to the appropriate specimen points. The relay closures necessary to accomplish the same switching achieved in the circuit of Fig. 1 are listed in the table of Fig. 2.

7.3.4 *Transistor Curve Tracer*, can be used for checking the linearity of contacts to low-resistivity material.

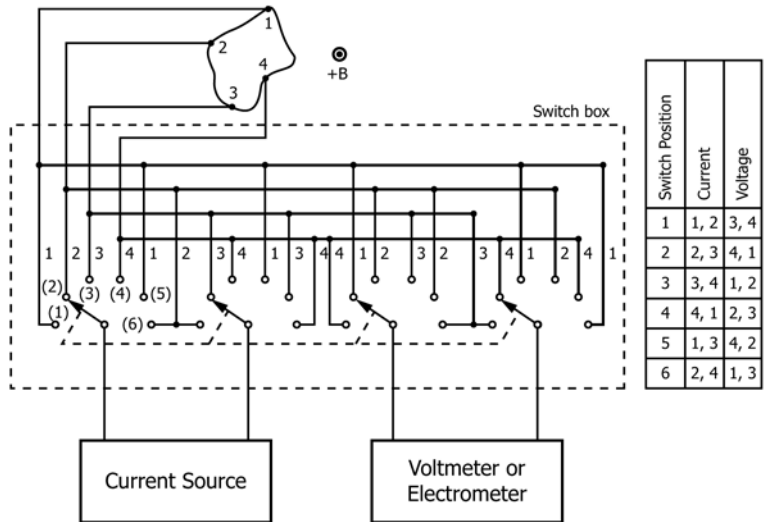
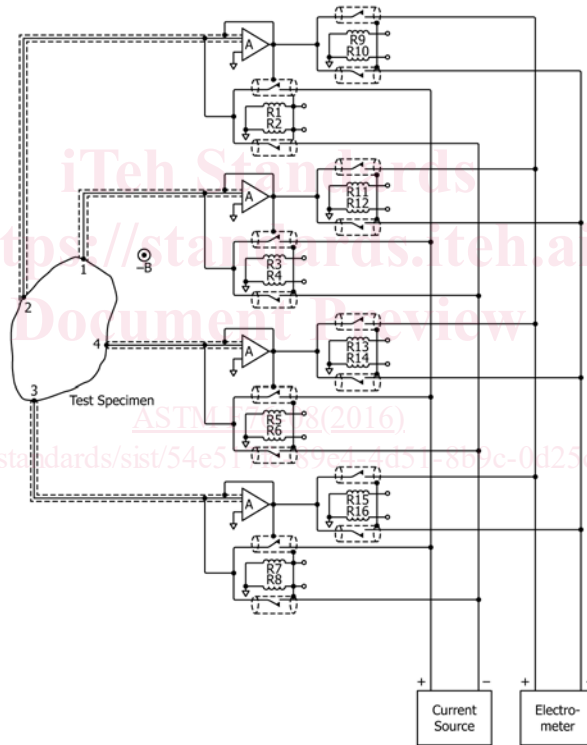

FIG. 1 Representative Manual Test Circuit for Measuring van der Pauw Specimens



NOTE 1—A—Unity gain amplifier

NOTE 2—R1–R16—Reed relays

Position	1	2	3	4	5	6
Switches	2, 3	1, 4	1, 8	2, 7	6, 7	5, 8
Closed	14, 15	14, 15	12, 13	12, 13	10, 11	10, 11
Current	1, 2	2, 1	2, 3	3, 2	3, 4	4, 3
Voltage	3, 4	3, 4	4, 1	4, 1	1, 2	1, 2

FIG. 2 Representative Test Circuit for Measuring High-Resistivity van der Pauw Specimens

7.3.5 All instruments must be maintained within their specifications through periodic calibrations.

7.4 Specimen Holder:

7.4.1 *Container*, if low-temperature measurements are required, of such dimensions that it will enclose the specimen holder (7.4.3) and fit between the magnetic pole pieces. A glass or metal dewar or a foamed polystyrene boat is suitable.

7.4.2 *Temperature Detector*, located in close proximity to the test specimen and associated instruments for monitoring temperature to an accuracy of $\pm 1^\circ\text{C}$ during the measurement. This may include, for example, a thermocouple, a platinum resistance thermometer, or a suitable thermistor.

7.4.3 *Opaque Container*, used to hold the specimen in position, to maintain an isothermal region around the specimen, and to shield the specimen from light and, in the case of low-temperature measurements, from room-temperature radiation. The mounting must be arranged so that mechanical stress on the specimen does not result from differential expansion when measurements are made at temperatures different from room temperature. If liquids, such as boiling nitrogen, are used to establish low temperatures, the liquid may be allowed to enter the specimen container directly through ports that are suitably shielded against the entry of light.

7.4.4 If a metal dewar or specimen holder is used, it must be constructed of nonmagnetic materials such that the value of magnetic flux density at the specimen position will not be altered more than $\pm 1\%$ by its presence.

7.4.5 To orient the specimen perpendicular to the magnetic field it is desirable to employ both geometrical and electrical tests. Sign conventions are defined in Fig. 3.

7.4.5.1 The specimen holder can usually be visually aligned parallel with the flat faces of the magnet along the long axis (usually the vertical axis) of the specimen holder in a satisfactory manner. Care should be taken that the specimen is mounted within the container so that the flat faces are parallel with an external portion of the specimen holder.

7.4.5.2 Because the dimensions are much shorter in the direction perpendicular to the long axis, electrical orientation is preferred. This is most conveniently performed by rotating the specimen with respect to the magnetic flux and measuring the transverse voltage as a function of angle between the magnetic flux and a reference mark on the specimen holder over a range a few degrees on each side of the nominal perpendicular position. The correct position is that where the average Hall

voltage is a maximum or, in some cases where orientation dependent effects are encountered, a minimum.

7.4.5.3 A more accurate method of electrical positioning involves rotation of the specimen with respect to the magnetic flux as in 7.4.5.2, but a few degrees around both positions approximately 90° away from the nominal perpendicular position. The correct angular position for the specimen during Hall-effect measurements is midway between the two points (about 180° apart) where the average transverse voltage is zero.

8. Reagents and Materials (See Section 9)

8.1 *Purity of Reagents*—All chemicals for which such specifications exist shall conform to SEMI Specifications C1. Reagents for which SEMI specifications have not been developed shall conform to the specifications of the Committee on Analytical Reagents of the American Chemical Society.⁶ Other grades may be used provided it is first ascertained that the reagent is sufficiently pure to permit its use without lessening the accuracy of the determination.

8.2 *Purity of Water*—When water is used it is either distilled water or deionized water having a resistivity greater than $2\text{ M}\Omega\cdot\text{cm}$ at 25°C as determined by the Non-Referee Tests of Test Methods D1125.

9. Test Specimen Requirements

9.1 Regardless of the specimen preparation process used, high-purity reagents and water are required.

9.2 *Crystal Perfection*—The test specimen is a single crystal.

NOTE 2—The procedure for revealing polycrystalline regions in silicon is given in Test Method F47.

NOTE 3—The crystallographic orientation of the slice may be determined if desired, using either the X-ray or optical techniques of Test Method F26.

9.3 *Specimen Shape*—The thickness shall be uniform to $\pm 1\%$. The minimum thickness is governed by the availability of apparatus which is capable of measuring the thickness to a precision of $\pm 1\%$. The test specimen shape can be formed by cleaving, machining, or photolithography. Machining techniques such as ultrasonic cutting, abrasive cutting, or sawing may be employed as required. Representative photolithographically defined test patterns are described in (10, 11, 12).

9.3.1 Although the specimen may be of arbitrary shape, one of the symmetrical configurations of Fig. 4 is recommended. The specimen must be completely free of (geometrical) holes. The recommended ratio of peripheral length of the specimen, L_p , to thickness of the specimen, t , is as follows:

$$L_p \geq 15t$$

Recommended thickness is less than or equal to 0.1 cm. This specimen shape can produce erroneous results when used on anisotropic materials (see 5.1.9 and Note X1.1).

⁶ "Reagent Chemicals, American Chemical Society Specifications," Am. Chemical Soc., Washington, DC. For suggestions on the testing of reagents not listed by the American Chemical Society, see "Reagent Chemicals and Standards," by Joseph Rosin, D. Van Nostrand Co., Inc., New York, NY, and the "United States Pharmacopeia."

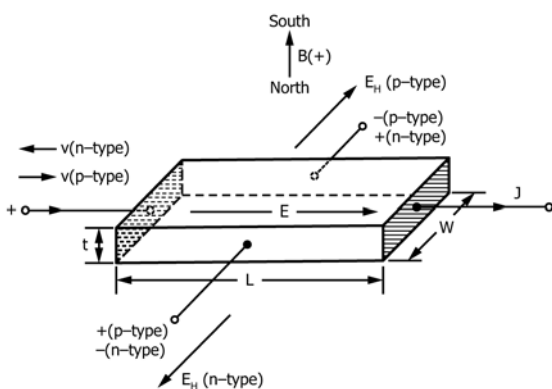

NOTE 1—The carrier velocity, V, for electrons and holes is in opposite directions as indicated.

FIG. 3 Hall-Effect Sign Conventions

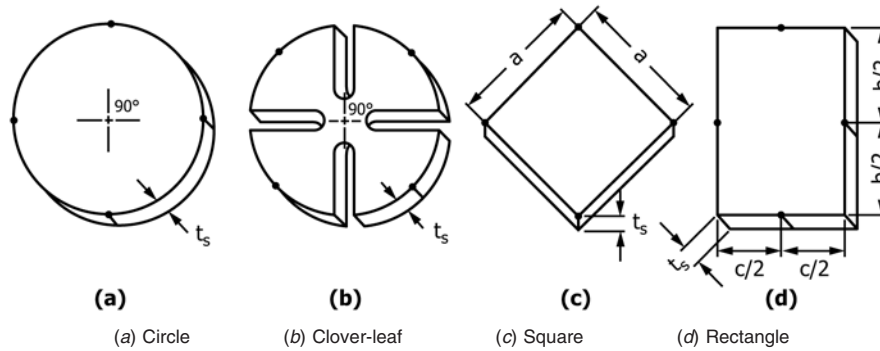

NOTE 1—Contact positions are indicated schematically by the small dots.

FIG. 4 Typical Symmetrical van der Pauw Specimens

9.4 Maintain the contact dimensions as small as possible relative to the peripheral length of the specimen. If possible, place the contacts on the specimen edge. Use line or dot contacts with a maximum dimension along the peripheral length, L_p , no greater than $0.05 L_p$. If the contacts must be placed on one of the two flat faces of the specimen that are separated by the dimension, t , make them as small as possible and locate them as close as possible to the edge (see 5.2.1 and 5.2.2).

10. Measurement Procedure

10.1 *Thickness Measurement*—Measure the specimen thickness (9.3) with a precision of $\pm 1\%$.

10.2 *Contact Evaluation*—Verify that all combinations of contact pairs in both polarities have linear current-voltage characteristics, without noticeable curvature, at the measurement temperature about the actual value of current to be used.

10.3 *Specimen Placement*—Place the clean and contacted specimen in its container (7.4.3). If a permanent magnet is used to provide the flux, keep the magnet and the specimen separate during the measurement of resistivity. If possible, move the magnet without disturbing the specimen and its holder, so as to minimize the possibility of a change of temperature which must remain within the $\pm 1^\circ\text{C}$ tolerance between the resistivity and Hall-effect measurements. If an electromagnet is used, be certain that the residual flux density is small enough not to affect the resistivity measurement.

10.4 *Resistivity Measurement*—Measure the temperature of the specimen. Set the current magnitude, I , to the desired value (see 5.1.2). Measure the voltages $V_{21,34}$, $V_{12,34}$, $V_{32,41}$, $V_{23,41}$, $V_{43,12}$, $V_{34,12}$, $V_{14,23}$, and $V_{41,23}$ (Note 4). Remeasure the specimen temperature to check the temperature stability. If the second measurement of the temperature differs from the first by more than 1°C , allow the temperature to stabilize further, and then repeat the procedure of 10.4.

NOTE 4—The notation to be used, $V_{AB,CD}$, refers to the potential difference $V_C - V_D$ measured between Contacts C and D when current enters Contact A and exits Contact B . Both the sign and magnitude of all voltages must be determined and recorded. For van der Pauw specimens, the contacts are labeled consecutively in counter-clockwise order around the specimen periphery. Similarly the resistance $R_{AB,CD}$ is defined as the ratio of the voltage $V_C - V_D$ divided by the current directed into Contact A and out of Contact B .

10.5 *Hall-Coefficient Measurement*—Position the specimen between the magnet-pole pieces so that the magnetic flux is perpendicular to the two flat faces of the specimen which are separated by the dimension, t , (7.4.5). If an electromagnet is used to provide the flux, follow the appropriate procedure in 10.5.1. If a permanent magnet of known flux density is used, omit the adjustment and measurement of flux density.

10.5.1 In high-mobility materials such as lightly doped n -type gallium arsenide, the proportionality factor, r , (see Appendix X1) varies with the applied magnetic field. For the purposes of interlaboratory comparison, users should therefore use a field of 5 gauss (0.5 T) in the absence of other information. This effect is not expected to be significant for dopant density above 10^{17} cm^{-3} in n -type gallium arsenide.

10.5.2 Measure the temperature of the specimen. Turn on the magnetic flux and adjust it to the desired positive value of magnetic flux density. Measure the magnetic flux density. Measure the voltages $V_{31,42} (+B)$, $V_{13,42} (+B)$, $V_{42,13} (+B)$, and $V_{24,13} (+B)$ (Note 4 and Note 5). Remeasure the value of the magnetic flux density in order to check the stability of the magnet. If the second value of magnetic flux density differs from the first by more than 1% , make the necessary changes, and repeat the procedure until the specified stability is achieved. Rotate the specimen 180° or reverse the magnetic flux, and adjust it to the same magnitude ($\pm 1\%$) of magnetic flux density. Measure the voltages $V_{24,13} (-B)$, $V_{42,13} (-B)$, $V_{13,42} (-B)$, and $V_{31,42} (-B)$ (Note 4 and Note 5). Measure the temperature and magnetic flux density and check the stability as before.

NOTE 5—The parenthetical symbols $(+B)$ and $(-B)$ refer to oppositely applied magnetic fields where positive field is defined in Fig. 3.

10.6 *Cautions*—See Section 5 for discussion of spurious results.

11. Calculations

11.1 *Resistivity*—Calculate the sample resistivity from the data of 10.4. Two values of resistivity, ρ_A and ρ_B , are obtained as follows (Note 4):

$$\rho_A = \frac{1.1331 f_A t}{I} [V_{21,34} - V_{12,34} + V_{32,41} - V_{23,41}] \quad (1)$$

and