



Standard Test Methods for Impact Resistance of Rigid Poly(Vinyl Chloride) (PVC) Building Products¹

This standard is issued under the fixed designation D4226; the number immediately following the designation indicates the year of original adoption or, in the case of revision, the year of last revision. A number in parentheses indicates the year of last reapproval. A superscript epsilon (ϵ) indicates an editorial change since the last revision or reapproval.

1. Scope*

1.1 These test methods cover the determination of the energy required to crack or break rigid poly(vinyl chloride) (PVC) plastic sheeting and profile flat sections used in building products, as well as extruded or molded test samples, under specified conditions of impact from a freefalling standard weight striking an impactor with either of two configurations in contact with the specimen.

1.2 Two test procedures are included:

1.2.1 *Procedure A*, used to determine minimum impact energy required to cause failure (hole, crack, split, shatter, or tear).

1.2.2 *Procedure B*, used to determine minimum impact energy required to cause brittle failure.

1.3 The values stated in inch-pound units are to be regarded as standard. The values given in parentheses are mathematical conversions to SI units that are provided for information only and are not considered standard.

NOTE 1—There is no known ISO equivalent to this standard.

1.4 The text of this standard references notes and footnotes which provide explanatory material. These notes and footnotes (excluding, those in tables in figures) shall not be considered as requirements of this standard.

1.5 *This standard does not purport to address all of the safety concerns, if any, associated with its use. It is the responsibility of the user of this standard to establish appropriate safety and health practices and determine the applicability of regulatory limitations prior to use.* Specific precautionary statements are given in Section 8.

2. Referenced Documents

2.1 *ASTM Standards:*²

D618 Practice for Conditioning Plastics for Testing

D883 Terminology Relating to Plastics

D3679 Specification for Rigid Poly(Vinyl Chloride) (PVC) Siding

D5947 Test Methods for Physical Dimensions of Solid Plastics Specimens

E178 Practice for Dealing With Outlying Observations

3. Terminology

3.1 *Definitions*—Definitions are in accordance with Terminology D883, unless otherwise indicated.

3.2 *Definitions of Terms Specific to This Standard:*

3.2.1 *failure (of test specimen, as related to impact resistance)*—signified by the presence of a punched hole, crack, split, shatter, or tear that was created in the target area by the impact of the falling weight (see Fig. 1).

3.2.2 *ductile failure (ductile break, as related to impact resistance)*—*resistance*—a tear or split having an angle greater than 0° at the tip and extending through the entire thickness of the specimen such that light is directly visible through the tear or split (see Fig. 1).

3.2.3 *brittle failure (brittle break, as related to impact resistance)*—*resistance*—a punched hole, split, or shatter where a piece of the specimen separates from the main part of the specimen or a crack that has a 0° angle at the tip as viewed by the naked eye (see Fig. 1).

¹ These test methods are under the jurisdiction of ASTM Committee D20 on Plastics and are the direct responsibility of Subcommittee D20.24 on Plastic Building Products. Current edition approved Sept. 1, 2011; May 1, 2016. Published September 2011; May 2016. Originally approved in 1983. Last previous edition approved in 2011 as D4226 – 10; D4226 – 11. DOI: 10.1520/D4226-11; 10.1520/D4226-16.

² For referenced ASTM standards, visit the ASTM website, www.astm.org, or contact ASTM Customer Service at service@astm.org. For *Annual Book of ASTM Standards* volume information, refer to the standard's Document Summary page on the ASTM website.

*A Summary of Changes section appears at the end of this standard

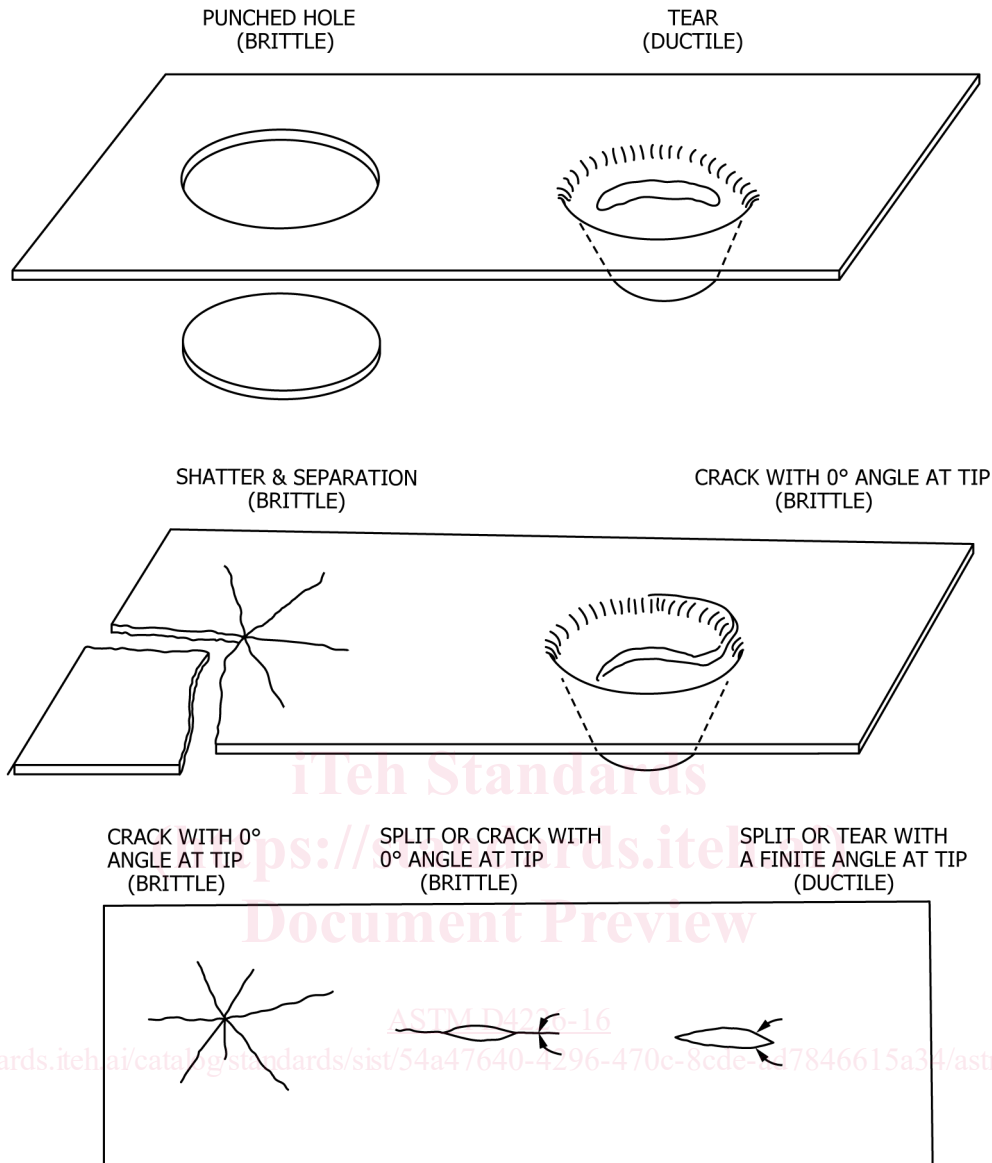

FIG. 1 Types of Failures of the Specimen

3.2.4 *mean failure height* (Procedure A)—the height from which the falling weight will cause 50 % of the specimens to fail.

3.2.5 *mean failure energy* (*mean impact resistance*), (Procedure A)—energy required to produce 50 % failures; the product of the weight and mean failure height.

3.2.6 *normalized mean failure energy* (*normalized mean impact resistance*)—*resistance*—the mean failure energy per unit (average) specimen thickness (Procedure A).

3.2.7 *mean brittle failure height*—the height from which the falling weight will cause 50 % brittle failures in specimens (Procedure B).

3.2.8 *mean brittle failure energy* (*mean energy of ductile-to-brittle transition*), (Procedure B)—energy required to produce 50 % brittle failures; the product of the weight and mean brittle failure height.

3.2.9 *normalized mean brittle failure energy* (*normalized mean energy of ductile-to-brittle transition*), (Procedure B)—the mean brittle failure energy per unit (average) specimen thickness.

3.2.10 *outlier*—an observation that appears to deviate markedly from other members of the sample in which it occurs.

4. Summary of Test Method

4.1 The building product profile is cut apart, if necessary, to obtain a flat specimen at least 0.75 in. (19 mm) wide.

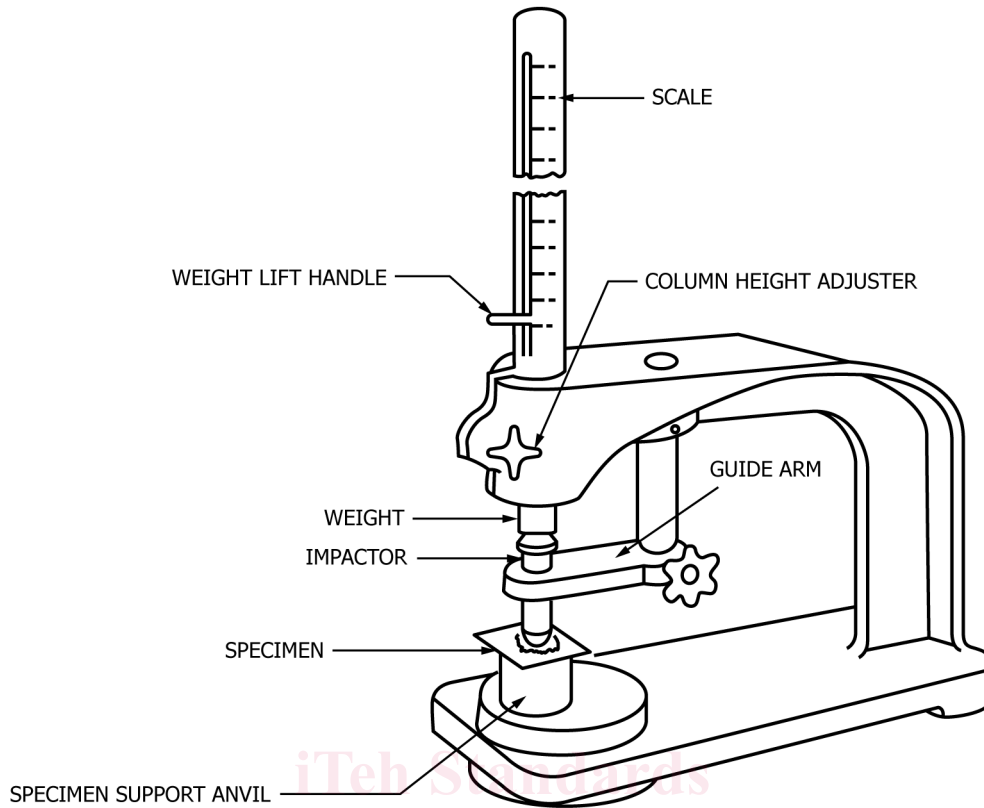

FIG. 2 Impact Tester

4.2 Procedure A establishes the height from which a standard falling 8-lb (3.6-kg) weight will cause 50 % of the specimens to fail.

4.3 Procedure B establishes the height from which a standard falling 8-lb (3.6-kg) weight will cause 50 % of the specimens to fail in a brittle mode.

4.4 Both procedures employ either of two configurations of impactor heads resting on the specimen. The specimen lays on a stand that has a 0.64-in. (16.3-mm) hole. The falling weight impacts on the impactor head tending to drive it through the specimen into the hole of the stand.

4.5 The technique used to find 50 % failure level in both procedures is commonly called the Bruceton Staircase Method or Up-and-Down Method. Testing is concentrated near the mean, reducing the number of specimens required to obtain a reasonably precise estimate.

5. Significance and Use

5.1 The impact strength values obtained on the flat sections of a building product profile are relevant only to the flat section that has been tested and these values do not necessarily indicate the impact resistance of the whole product, which is affected by the configuration of the profile (that is, corners, ribs, etc).

5.2 Constant weight and variable height, employed in these test methods, allow the velocity of impact to vary and, therefore, by Procedure B, can determine the energy of ductile-to-brittle transition, which cannot be determined if a variable weight is dropped from a constant height.

5.3 These test procedures have been found to be useful elements in rigid poly(vinyl chloride) (PVC) building product characterization. Compound qualification, finished product quality control, environmental and weatherability research and development studies, and fabrication tolerance prediction constitute useful applications.

5.4 Choice of the specific impactor head configuration used is related to a variety of product attributes, such as specimen thickness and product toughness as well as abstract factors, such as the anticipated mode of failure in a specific application. The geometric uniqueness of the impactor head configurations prevents any comparison or correlation of testing results on samples tested with differing impactor head configurations. In general, the conical impactor, C.125, is useful to ensure failure of thicker specimens where the H.25 impactor caused no failure.

NOTE 2—Equivalent surface conditions are more likely to occur when specimens are prepared by compression molding or extrusion than by injection molding.

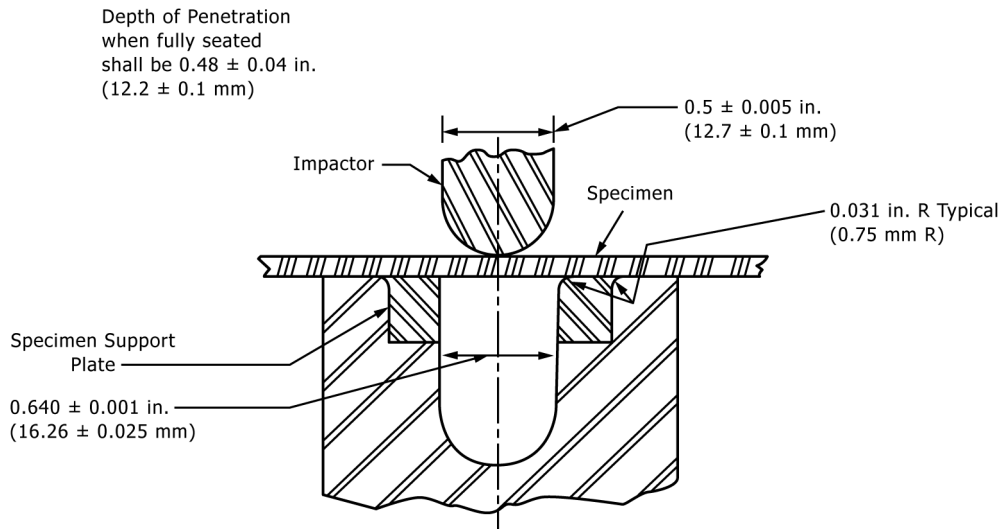

FIG. 3 Impactor Head Configuration H.25 Specimen Support Detail

5.5 When comparing different samples tested with the same impactor head configuration, impact resistance shall be permitted to be normalized for average specimen thickness over a reasonably broad range (for example, 1 to 3 mm).³ However, this should only be done when the surface conditions listed in 6.1 are essentially equivalent.

6. Interferences

6.1 The results obtained are greatly influenced by the quality of the test specimens. Cracks usually start at the surface in tension; the surface opposite the one that is struck by the impactor head. The composition of this surface layer and the degree of orientation introduced during the formation of the specimen are very important variables. Flaws in this surface will also affect results. Because of these factors, sometimes additional information about the sample is achieved by testing the sample from a variety of locations in a product or testing from both sides of a flat section.

7. Apparatus

7.1 *Testing Machine*—The apparatus shall be constructed essentially as shown in Fig. 2 and Fig. 3 and shall consist of the following: suitable base to withstand the impact shock; steel-rod impact weight weighing 8 ± 0.2 lb (3.6 ± 0.1 kg); hardened steel impactors as specified in 7.1.1-7.1.2; a slotted guide tube 40 in. (1.0 m) in length in which the impact weights slide, having an internal diameter sufficient so that friction does not reduce the weight velocity, and having graduations in inch-pound (newton-metre) increments, or multiples thereof. A bracket is used to hold the tube in a vertical position by attaching it to the base and also to hold the hand knob, which is a pivot-arm alignment for the impactor, about 2 in. (50 mm) under the tube. The top edge of the opening in the specimen support plate should be rounded to a 0.031-in. (0.8-mm) radius. Fig. 3 shows the specimen support configuration for this test.

7.1.1 The tester shall be mounted so that the axis of the tube is plumb when measured with a spirit level at least 1 ft (300 mm) in length.

7.1.2 Impactor Configurations:

7.1.2.1 *Impactor C.125* shall be constructed, as is shown in Fig. 4, of tough, hardened (Rockwell C50-55), scratch resistant steel. It should have a conical (40°) configuration and 0.125-in. (3.18-mm) radius hemispherical tip.

7.1.2.2 *Impactor H.25* shall be constructed, as is shown in Fig. 3, of tough, hardened (Rockwell C50-55) scratch resistant steel. It should have a 0.25-in. (6.35-mm) radius hemispherical tip (see Fig. 3 and Fig. 4).

7.1.2.3 The surface of the impactor head shall be polished free of nicks, scratches, or other surface irregularities.

7.2 *Supporting Base*—In order to minimize the energy absorption, compression, and deflection of the support the tester shall be firmly fixed to a dense, solid, block or base.

7.2.1 The main body of said block or base shall have maximum dimensions of 16 in. (h) × 30 in. (w) × 30 in. (d) and shall have a minimum weight of ~~400 lbs~~ 375 lb. This block shall be placed at a height that facilitates equipment usage. It is not necessary to bolt blocks or bases of this weight to the floor.

NOTE 3—The required block weight and dimensions conform to commercially available butcher block type tables.

³ O.R. Weaver, "Using Attributes to Measure a Continuous Variable in Impact Testing Plastic Bottles," Materials Research & Standards, MR & S, Vol. 6, No. 6, June, 1996, pp. 285-291.

iTeh Standards
(<https://standards.itih.ai>)
Document Preview

ASTM D4226-16

7.2.2 Alternative supporting bases or those lighter than ~~400 lbs~~ 375 lb should be bolted to a concrete floor. Mean failure energy comparisons shall be made between these alternative supports and one where the tester is bolted directly to the concrete floor. If mean failure energy differences between the concrete floor and the alternative support are found statistically nonsignificant, use of the lighter support shall be allowed.

7.2.3 If the weight of the butcher block that was originally 375 lb or greater decreases with time to less than 375 lb, increase the block weight to a minimum of 375 lb by adding a suitable amount of weight to the bottom of the table. The weight shall be tightly affixed and in direct contact with the bottom of the table and not cause any vibrations during the impact test.

NOTE 4—The weight of the butcher block can decrease over time due, for instance to drying.

7.2.4 Use of rubber mats either under the tester or the supporting base is prohibited.

7.3 *Micrometer*, for measurement of specimen thickness. It should be accurate to 1 % of the average thickness of specimens used. See Test Method [D5947](#) for suitable micrometers.

8. Safety Precautions

8.1 Shielding devices shall be provided to protect personnel.

8.2 A tube can contain the impactor head if it rebounds after striking a specimen, or the impactor head may be drilled for a cotterpin to prevent rebound. The cotterpin must be located well above the penetration depth of the impactor head.

9. Sampling

9.1 Sample in a statistically acceptable manner. The samples shall be representative of the lot under study.

10. Test Specimen

10.1 Flat test specimens at least 0.75-in. (19-mm) wide are permitted to be tested. The specimens shall be free of obvious imperfections unless they constitute variables under study.

10.2 When the approximate mean failure height for a given sample is known, 20 specimens usually yield sufficiently precise results. If the mean failure height cannot be approximated, six or more specimens ~~should~~shall be used to determine the appropriate starting point of the test.

NOTE 5—Specimen quantity, as small as five, often yields sufficiently reliable estimates of the mean failure height. However, the estimated standard deviation will be relatively large.⁴

11. Conditioning

11.1 Unless otherwise specified, condition the test specimens at $73.4 \pm 3.6^\circ\text{F}$ ($23 \pm 2^\circ\text{C}$) and $50 \pm 5\%$ ~~10%~~ relative humidity for not less than 40 h prior to test in accordance with Procedure A of Methods D618. In cases of disagreement, the tolerance shall be $\pm 1.8^\circ\text{F}$ ($\pm 1^\circ\text{C}$) and $\pm 2\%$ ~~$\pm 5\%$~~ relative humidity.

11.2 *Quality Control Tests*—Condition the test specimens at $73.4 \pm 3.6^\circ\text{F}$ ($23 \pm 2^\circ\text{C}$) for 4 h in air.

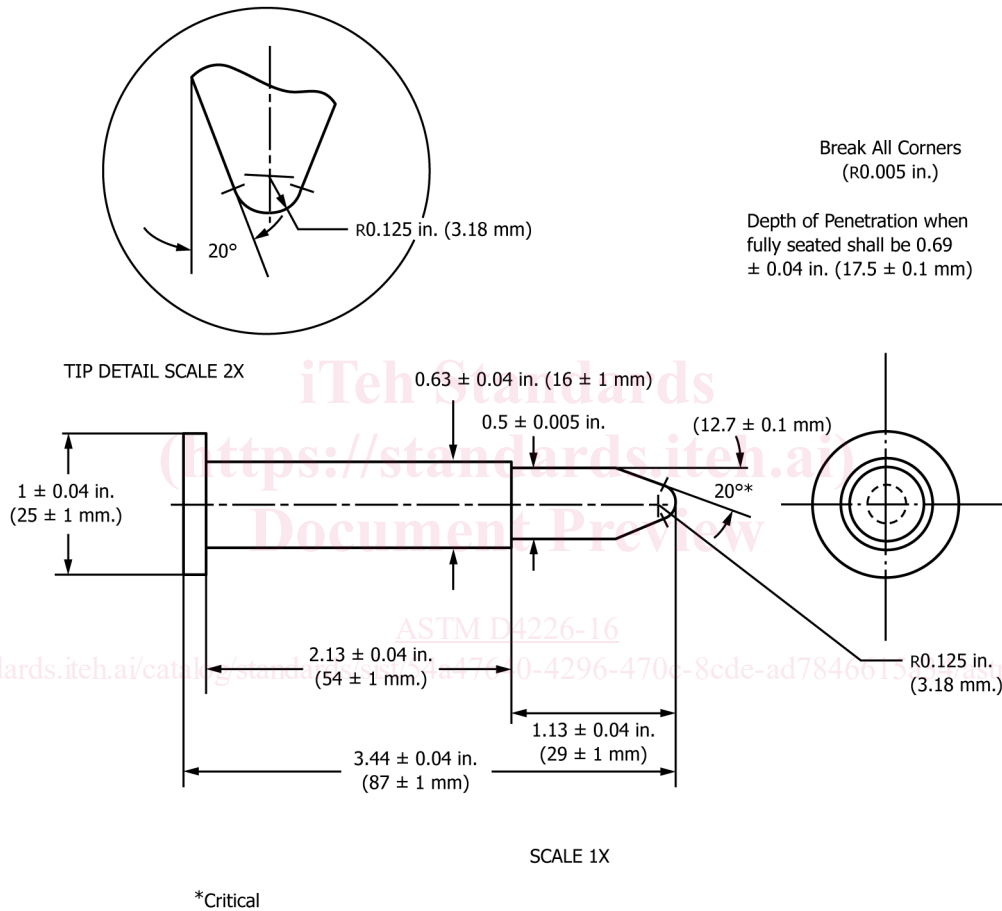

FIG. 4 Impactor Head Configuration C.125

12. Procedure

12.1 *Procedure A:*

12.1.1 ~~Measure~~—When testing individual specimens or coupons, measure and record the thickness of each specimen at the anticipated area of impact. Average the values for all specimens in a sample and use this average thickness in calculating normalized mean failure energy; all values to determine average thickness. When using a single large specimen such as a strip of PVC siding, measure the thickness at five points uniformly down the length of PVC siding under test. Use the average of these five values as the average thickness. The thickness of any individual measurement shall not vary by more than 5% from the average thickness.

NOTE 5—When using a large specimen, such as PVC siding, measure the thickness at five points uniformly across the width of the specimen. Use the average of these five values as the average thickness to calculate the normalized mean failure energy.

⁴ Brownless, K. A., Hodges J. L., Jr., and Rosenblatt, Murray, "The Up-and-Down Method with Small Samples," *American Statistical Association Journal*, JSTNA, Vol. 48, 1953, pp. 262-277.