International Standard



3856/7

INTERNATIONAL ORGANIZATION FOR STANDARDIZATION • МЕЖДУНАРОДНАЯ ОРГАНИЗАЦИЯ ПО СТАНДАРТИЗАЦИИ • ORGANISATION INTERNATIONALE DE NORMALISATION

Paints and varnishes — Determination of “soluble” metal content — Part 7 : Determination of mercury content of the pigment portion of the paint and of the liquid portion of water- dilutable paints — Flameless atomic absorption spectrometric method

Peintures et vernis — Détermination de la teneur en métaux «solubles» — Partie 7 : Détermination de la teneur en mercure contenu dans le pigment et dans la fraction liquide des peintures hydrodiluable — Méthode par spectrométrie d'absorption atomique sans flamme

First edition — 1984-12-15

UDC 667.6 : 543.422 : 546.49

Ref. No. ISO 3856/7-1984 (E)

Descriptors : paints, varnishes, pigments, chemical analysis, determination of content, soluble matter, mercury, atomic absorption method.

Price based on 8 pages

Foreword

ISO (the International Organization for Standardization) is a worldwide federation of national standards bodies (ISO member bodies). The work of preparing International Standards is normally carried out through ISO technical committees. Each member body interested in a subject for which a technical committee has been established has the right to be represented on that committee. International organizations, governmental and non-governmental, in liaison with ISO, also take part in the work.

Draft International Standards adopted by the technical committees are circulated to the member bodies for approval before their acceptance as International Standards by the ISO Council. They are approved in accordance with ISO procedures requiring at least 75 % approval by the member bodies voting.

International Standard ISO 3856/7 was prepared by Technical Committee ISO/TC 35, *Paint and varnishes*.

ITEH STANDARD PREVIEW
(standards.iteh.ai)

<https://standards.iteh.ai/catalog/standards/sist/391fff85-7fc9-4c11-8e2e-d9f804f0c071/iso-3856-7-1984>

Paints and varnishes — Determination of “soluble” metal content —

Part 7: Determination of mercury content of the pigment portion of the paint and of the liquid portion of water-dilutable paints — Flameless atomic absorption spectrometric method

0 Introduction

This International Standard is a part of ISO 3856, *Paints and varnishes — Determination of “soluble” metal content*.

ISO 3696, *Water for laboratory use — Specifications*.²⁾

ISO 6713, *Paints and varnishes — Preparation of acid extracts from paints in liquid or powder form*.

1 Scope and field of application

This part of ISO 3856 describes a flameless atomic absorption spectrometric method for the determination of the mercury content of the test solutions, prepared according to ISO 6713 or other suitable International Standards.

The method is applicable to paints having “soluble” mercury contents in the range of about 0,005 to 0,05 % (*m/m*), but the part of this method covering the examination of the liquid portion of the paint is restricted to water-dilutable paints.

CAUTION — The procedures described in this part of ISO 3856 are intended to be carried out by qualified chemists or by other suitably trained and/or supervised personnel. The substances and procedures used in this method may be injurious to health if adequate precautions are not taken. Attention is drawn in the text (see 4.6 and 4.7) to certain specific hazards. This part of ISO 3856 refers only to its technical suitability and does not absolve the user from statutory obligations relating to health and safety.

2 References

ISO 385/1, *Laboratory glassware — Burettes — Part 1: General requirements*.¹⁾

ISO 648, *Laboratory glassware — One-mark pipettes*.

ISO 1042, *Laboratory glassware — One-mark volumetric flasks*.

3 Principle

Oxidation of the mercury compounds contained in the test solution obtained from the pigment portion of the paint or combustion with oxygen in an enclosed system of the evaporation residue of the test solution obtained from the liquid portion of water-dilutable paints.

Reduction of the mercury(II) compounds contained in the resulting solutions to elementary mercury. Entrainment of the mercury in a current of gas at ambient temperature and determination of the mercury, as the monoatomic vapour, by cold vapour (flameless) atomic absorption spectrometry at a wavelength in the region of 253,7 nm.

4 Reagents and materials

During the analysis, use only reagents of recognized analytical grade and water of at least grade 3 purity according to ISO 3696.

4.1 Oxygen, commercial grade, in a steel cylinder.

4.2 Tin(II) chloride dihydrate, 100 g/l solution.

Dissolve 25 g of tin(II) chloride dihydrate ($\text{SnCl}_2 \cdot 2\text{H}_2\text{O}$) in 50 ml of 35 % (*m/m*) (ρ approximately 1,18 g/ml) hydrochloric acid and dilute to 250 ml with water. Add a few granules of metallic tin and heat until any precipitate disappears. Ensure that a few granules of bright tin are present to stabilize the solution and, before use, that there is no precipitate.

1) At present at the stage of draft. (Partial revision of ISO/R 385-1964.)

2) At present at the stage of draft.

4.3 Sulfuric acid, 5 % (*m/m*).

4.4 Nitric acid, approximately 65 % (*m/m*) (ρ approximately 1,40 g/ml).

4.5 Potassium permanganate, 60 g/l solution.

Dissolve 60 g of potassium permanganate (KMnO_4) in water and dilute to 1 litre.

4.6 Hydroxylammonium chloride, 20 % (*m/m*) solution.

WARNING — Hydroxylammonium chloride is toxic, corrosive and an irritant. Avoid contact with eyes and skin.

Dissolve 20 g of hydroxylammonium chloride (NH_2OHCl) in about 75 ml of water and dilute to 100 ml.

4.7 Mercury, standard stock solution containing 100 mg of Hg per litre.

WARNING — Mercury, particularly in its vapour form, and its solutions are toxic. Avoid breathing mercury vapour. Avoid contact of mercury or its solutions with eyes and skin. Carry out all procedures in a well-ventilated fume cupboard.

Either

a) transfer the contents of an ampoule of a standard mercury solution containing exactly 0,1 g of Hg into a 1 000 ml one-mark volumetric flask, dilute to the mark with the 5 % (*m/m*) sulfuric acid (4.3) and mix well;

or

b) weigh, to the nearest 0,1 mg, 0,135 4 g of mercury(II) chloride, dissolve in the sulfuric acid (4.3) in a 1 000 ml one-mark volumetric flask, dilute to the mark with the same sulfuric acid and mix well.

1 ml of this standard stock solution contains 0,1 mg of Hg.

4.8 Mercury, standard solution containing 1 mg of Hg per litre.

Prepare this solution on the day of use.

Pipette 10 ml of the standard stock solution (4.7) into a 1 000 ml one-mark volumetric flask, dilute to the mark with the sulfuric acid (4.3) and mix well.

1 ml of this standard solution contains 1 μg of Hg.

5 Apparatus

Ordinary laboratory apparatus and

5.1 Atomic absorption spectrometer, suitable for measurements at a wavelength of 253,7 nm and capable of operating with the measuring cell specified in 5.2.

NOTE — If special commercial mercury analyzers using the cold vapour AAS principle are used (see note to 6.1.2.1), appropriate amendment of the procedure described in 6.1.2 and 6.3.2 may be necessary and this should be recorded in the test report.

5.2 Measuring cell, with windows (for example of quartz) transparent to ultraviolet radiation (in the region of 253,7 nm), the optical path length of which should be appropriate to the spectrometer being used, but not less than 100 mm.

5.3 Mercury hollow-cathode lamp or mercury discharge lamp.

5.4 Potentiometric chart recorder.

NOTE — A suitable peak measuring device such as an electronic integrator may be used as an alternative.

5.5 Combustion flask or separating funnel, of capacity 500 ml, with a ground-glass joint.

5.6 Test portion holder (platinum gauze combustion basket) and **firing adapter**, suitable for fitting to the combustion flask (5.5) (see figure 1).

5.7 Spark generator.

NOTE — A high-frequency vacuum tester has been found to be satisfactory.

5.8 Flowmeter, fitted with a stainless steel needle valve and capable of measuring flow rates within the range 0,4 to 3 l/min.

5.9 Pump, diaphragm type, capable of giving controlled air flow rates of 0,4 to 3 l/min, or **cylinder of compressed air or nitrogen** equipped with a suitable pressure regulating valve.

5.10 Reaction vessel, comprising a test tube, of capacity 25 ml, with a ground-glass joint neck to fit an interchangeable head and a four-way stopcock (see figure 2).

5.11 Equipment, to prevent any condensation of water vapour in the measuring cell. Any appropriate system may be used for this purpose (for example an infra-red lamp, a black electrical heating element, or a rod heater).

5.12 Flexible acid-resistant tubing (for example silicone rubber tubing), suitable for connecting the apparatus (see figure 2).

5.13 Capsules, of hardened gelatine, pharmaceutical grade.

5.14 Rotary evaporator, water cooled, capable of operation under vacuum with a rotation rate of 150 r/min.

5.15 Water-bath, capable of being maintained at 45 ± 5 °C.

5.16 Burettes, of capacity 10 ml and 25 ml, complying with the requirements of ISO 385/1.

5.17 One-mark volumetric flasks, of capacity 25 ml, 100 ml and 500 ml, complying with the requirements of ISO 1042.

5.18 Pipettes, of capacity 1 ml, 5 ml and 25 ml, complying with the requirements of ISO 648.

5.19 Balance, capable of weighing to 0,1 mg.

6 Procedure

6.1 Preparation of the calibration graph

6.1.1 Preparation of the standard matching solutions

Prepare these solutions on the day of use.

Into a series of six 25 ml one-mark volumetric flasks (5.17), introduce from the 10 ml burette (5.16), respectively, the volumes of the standard mercury solution (4.8) shown in the following table, dilute each to the mark with the sulfuric acid (4.3) and mix well.

Standard matching solution No.	Volume of the standard mercury solution (4.8)	Corresponding concentration of Hg in the standard matching solution
	ml	µg/ml
0*	0	0
1	1	0,04
2	2	0,08
3	3	0,12
4	4	0,16
5	5	0,20

* Blank matching solution.

6.1.2 Spectrometric measurement

6.1.2.1 Install the measuring cell (5.2) and the mercury spectral source (5.3) in the spectrometer (5.1) and optimize the conditions for the determination of mercury. Adjust the instrument in accordance with the manufacturer's instructions and adjust the monochromator to the region of 253,7 nm in order to obtain the maximum absorbance. Connect the flowmeter (5.8), pump (5.9), reaction vessel (5.10) and measuring cell (5.2) with the minimum lengths of flexible tubing (5.12) as shown in figure 2.

NOTE — A closed-circuit measuring system may be used in which the mercury is recirculated by means of a pump. This will be particularly effective when the release of mercury vapour is delayed by interfering substances, e.g. bromide ions.

6.1.2.2 Switch on the pump and move the four-way stopcock to the by-pass position. Adjust the needle valve or open the gas regulating valve to give a suitable flow rate (for example

1 l/min). Set the potentiometric chart recorder (5.4) to the appropriate range. Adjust the zero of the recorder to a suitable position on the chart and check for baseline drift and noise level (see 6.1.2.4).

6.1.2.3 Disconnect the reaction vessel and, using a pipette (5.18), place 5 ml of the standard matching solution No. 5 into the vessel. Add by means of a pipette (5.18) 1 ml of the tin(II) chloride solution (4.2), mix well and immediately reconnect the reaction vessel. Reverse the four-way stopcock to allow the liberated mercury vapour to be swept through the measuring cell.

6.1.2.4 A peak will be indicated on the recorder chart and, by means of the potentiometer and flow range controls, adjust the height of the peak on the chart to about one-half the full-scale reading. Ensure that a sharp peak is obtained. Repeat if a further check of the adjustment is required.

Return the stopcock to the by-pass position and repeat the procedure using 5 ml aliquot portions of the remaining standard matching solutions.

NOTE — It may be necessary to repeat the initial test several times using the standard matching solution No. 5 in order to optimize the characteristics of the system.

6.1.3 Calibration graph

Plot a graph having the masses, in micrograms, of Hg contained in 1 ml of the standard matching solutions as abscissae and the corresponding peak heights or, more precisely, the peak areas (for example, the products of the peak height and the peak width at half the peak height), reduced by the value for the blank matching solution, as ordinates.

Over this range the curve should deviate only slightly from linearity.

NOTE — Contamination of any portion of the apparatus with aromatic solvents may give false high results owing to absorption in the region of 254 nm.

6.2 Test solutions

6.2.1 Pigment portion of the liquid paint and paint in powder form

6.2.1.1 Use the solutions obtained by the procedure described in sub-clause 8.2.3 of ISO 6713.

Carry out the following oxidation procedure in duplicate.

Pipette a 5 ml aliquot portion of each test solution into individual 100 ml one-mark volumetric flasks (5.17). Add to each flask, 50 ml of the sulfuric acid (4.3), followed by 10 ml of the potassium permanganate solution (4.5). Allow to stand for a minimum of 2 h or preferably overnight to ensure that the mercury is present as Hg(II). After this period, add 2 ml of the hydroxylammonium chloride solution (4.6) and mix gently to obtain a clear, almost colourless solution. Dilute to the mark with the sulfuric acid (4.3) and mix well.

Retain these solutions for the determination of the mercury content of the pigment portion of the paint.

6.2.1.2 Carry out the procedure described in 6.2.1.1 in duplicate on 5 ml aliquot portions taken from the blank test solution obtained by the procedure described in sub-clause 8.4 of ISO 6713.

Retain these solutions as the blank test solutions for the pigment portion of the paint.

6.2.2 Liquid portion of the paint

NOTE — The following procedure should be carried out only if the liquid portion has been obtained from a water-dilutable paint.

6.2.2.1 Combine the liquid portions obtained according to sub-clause 6.4.2 (method B) of ISO 6713, using acetone, preferably, for all extractions. Make up to a total volume of 500 ml with acetone in a one-mark volumetric flask and mix well.

NOTE — For paints with a high pigment content, it may not be necessary to extract such a large amount of paint and in these cases the total volume of liquors will be considerably less than 500 ml. If this is so, it will be acceptable to make up to a smaller total volume, but it will be necessary to adjust correspondingly the aliquot portion taken for the test and the calculation (see 7.1.2).

6.2.2.2 Pipette 25 ml of the combined liquors (6.2.2.1) into a tared 100 ml round-bottomed flask having a ground-glass neck which fits the rotary evaporator (5.14). Fit the flask on to the rotary evaporator and adjust the speed to about 150 r/min. To increase the rate of evaporation, place a water-bath (5.15) maintained at 45 ± 5 °C under the flask and continue the evaporation until no volatile solvents remain. Remove the flask from the evaporator, dry the outside with a clean tissue and reweigh the flask to determine the mass of non-volatile residue.

NOTE — Application of vacuum to the rotary evaporator may be necessary to facilitate the removal of higher boiling solvents.

6.2.2.3 Carry out the following procedure in duplicate.

Place a test portion of approximately 20 mg of the residue (6.2.2.2) in a tared gelatine capsule (5.13) and close immediately. Weigh the capsule and test portion to the nearest 0,1 mg.

Place the weighed capsule in the test portion holder (5.6) (see figure 1). Fill the combustion flask (5.5) with the oxygen (4.1) at atmospheric pressure, quickly introduce from a 10 ml burette (5.16) 3 ml of the nitric acid (4.4) and insert the test portion holder making a gas tight seal at the ground-glass joint. Attach the spark generator (5.7) to the electrical leads of the test portion holder (see figure 3), place the apparatus behind a safety screen and switch on the high voltage to activate the spark and ignite the test portion.

After combustion is complete, shake the flask and contents and allow to stand for 30 min with occasional shaking. Remove the test portion holder and add to the flask 22 ml of water from a 25 ml burette (5.16). Replace the test portion holder and shake thoroughly.

Retain the bulk of the contents of the combustion flask in a stoppered glass container of capacity approximately 25 ml.

6.2.2.4 Pipette a 5 ml aliquot portion of each solution obtained from 6.2.2.3 into individual 100 ml one-mark volumetric flasks (5.17), dilute to the mark with the sulfuric acid (4.3) and mix well.

Retain these solutions for the determination of the mercury content of the liquid portion of the paint.

NOTE — As a result of the previous combustion of the test portion, it is unnecessary at this stage to oxidize with potassium permanganate.

6.2.2.5 Carry out rotary evaporation of a 25 ml portion of the acetone used to make up the combined liquid portions in 6.2.2.1. Retain this as the blank test solution for the liquid portion of the paint.

NOTE — Good quality redistilled solvent should be completely mercury-free and if this is used the procedure given in 6.2.2.5 may be omitted. If a residue is obtained following rotary evaporation it will be necessary to prepare a blank test solution as described in 6.2.2.1, 6.2.2.3 and 6.2.2.4.

6.2.3 Other test solutions

Use the test solutions obtained by other specified or agreed procedures. Carry out the procedure described in 6.2.1.1 including the oxidation process if the mercury has to be converted to Hg(II).

Prepare blank test solutions using the identical procedure but omitting the test solution.

6.3 Determination

6.3.1 Carry out the determination for each test solution (6.2.1.1, 6.2.2.4 or 6.2.3).

6.3.2 Measure with a pipette a volume of the solution (6.3.1) into the reaction vessel (5.10) such that its peak reading will lie on the ordinate of the calibration graph. Add by means of a pipette (5.18) 1 ml of the tin(II) chloride solution (4.2), mix well and immediately reconnect the reaction vessel. Reverse the four way stopcock to allow the liberated mercury vapour to be swept through the measuring cell.

Record the peak reading (i.e. either peak height or peak area; see 6.1.3), reduced by the reading obtained for the blank test solution. Read the mercury concentration from the calibration graph.

If the response of a test solution is higher than that of the standard matching solution with the highest mercury concentration (that is matching solution No. 5), dilute the test solution appropriately (dilution factor F) with a known volume of the sulfuric acid (4.3) before repeating the determination.

6.3.3 Carry out a blank test immediately after the determination, following the same procedure, using the solution obtained in 6.2.1.2, 6.2.2.5 or 6.2.3, as appropriate.

6.3.4 Calculate the mean of the duplicate readings. If the readings differ by more than 20 % of the mean, repeat the determination.

7 Expression of results

7.1 Calculations

7.1.1 Pigment portion of the liquid paint

Calculate the mass of "soluble" mercury in the hydrochloric acid extract obtained by the method described in sub-clause 8.2.3 of ISO 6713 using the equation

$$m_0 = \frac{a_1 - a_0}{10^6} \times \frac{V_1}{V_3} \times \frac{100}{5} \times F_1$$

$$= 2 \times 10^{-5} (a_1 - a_0) \frac{V_1}{V_3} \times F_1$$

where

a_0 is the mercury concentration, in micrograms per millilitre, of the blank test solution prepared by the method described in sub-clause 8.4 of ISO 6713;

a_1 is the mercury concentration, in micrograms per millilitre, of the test solution obtained from the calibration graph;

F_1 is the dilution factor referred to in 6.3.2;

m_0 is the mass, in grams, of "soluble" mercury in the hydrochloric acid extract;

V_1 is the volume, in millilitres, of the hydrochloric acid plus ethanol used for the extraction described in sub-clause 8.2.3 of ISO 6713 (assumed to be 77 ml);

V_3 is the volume, in millilitres, of treated test solution pipetted into the reaction vessel according to 6.3.2.

Calculate the "soluble" mercury content of the pigment portion of the liquid paint, using the equation

$$c_{\text{Hg1}} = m_0 \times \frac{10^2}{m_1} \times \frac{P}{10^2} = \frac{m_0 \times P}{m_1}$$

where

c_{Hg1} is the "soluble" mercury content, of the pigment portion of the liquid paint, expressed as a percentage by mass of the paint;

m_1 is the mass, in grams, of the test portion taken to prepare the solution described in sub-clause 8.2.3 of ISO 6713.

P is the pigment content of the liquid paint, expressed as a percentage by mass, obtained by the appropriate method described in clause 6 of ISO 6713;

7.1.2 Liquid portion of the paint

Calculate the mass of mercury in the liquid portion of the paint (see 6.2.2) obtained according to 6.4.2 (method B) of ISO 6713 using the equation

$$m_2 = \frac{(b_1 - b_0) \times m_3 \times V_{\text{tot}} \times 100}{V_2 \times m_4} \times F_2$$

where

b_0 is the mercury concentration, in micrograms per millilitre, of the blank test solution (6.3.4);

b_1 is the mercury concentration, in micrograms per millilitre, of the test solution obtained from the calibration graph;

F_2 is the dilution factor referred to in 6.3.2;

m_2 is the mass, in grams, of mercury in the liquid portion of the paint;

m_3 is the total mass, in grams, of the non-volatile residue obtained according to 6.2.2.2;

m_4 is the mass, in grams, of the non-volatile residue test portion taken according to 6.2.2.3;

V_{tot} is the total volume, in millilitres, of liquor prepared according to 6.2.2.1;

V_2 is the volume, in millilitres, of the solution obtained after the combustion (6.2.2.3).

Calculate the mercury content of the liquid portion of the paint using the equation

$$c_{\text{Hg2}} = \frac{m_2}{m_5} \times 10^2$$

where

c_{Hg2} is the mercury content of the liquid portion of the paint, expressed as a percentage by mass of the paint;

m_5 is the total mass, in grams, of paint comprising a "set" as described in sub-clause 6.4 of ISO 6713.

7.1.3 Liquid paint

Calculate the total "soluble" mercury content of the liquid paint as the sum of the results obtained according to 7.1.1 and 7.1.2, thus

$$c_{\text{Hg3}} = c_{\text{Hg1}} + c_{\text{Hg2}}$$

where c_{Hg3} is the total "soluble" mercury content of the paint, expressed as a percentage by mass.

7.1.4 Paint in powder form

The total "soluble" mercury content of the paint in powder form is obtained by appropriate modification of the calculations given in 7.1.1.

7.1.5 Other test solutions

If the test solutions were prepared by methods other than those given in ISO 6713 (see 6.2.3), it will be necessary to modify the equations for the calculation of mercury content given in 7.1.1 and 7.1.2.

7.2 Precision

No precision data are currently available.

8 Test report

The test report shall contain at least the following information :

- a) the type and identification of the product tested;
- b) a reference to this International Standard (ISO 3856/7);
- c) the method for the separation of the solid portion of the product under test according to ISO 6713, clause 6 (method A, B or C), where appropriate¹⁾;
- d) the solvent or the solvent mixture used for the extraction, where appropriate¹⁾;
- e) the results of the test, expressed as a percentage by mass of the product : either
 - the "soluble" mercury content of the pigment portion of the paint, the mercury content of the liquid portion of the paint and the total "soluble" mercury content of the liquid paint,
- or
 - the total "soluble" mercury content of the paint in powder form;
- f) any deviation, by agreement or otherwise, from the test procedure specified;
- g) the date of the test.

Dimensions in millimetres

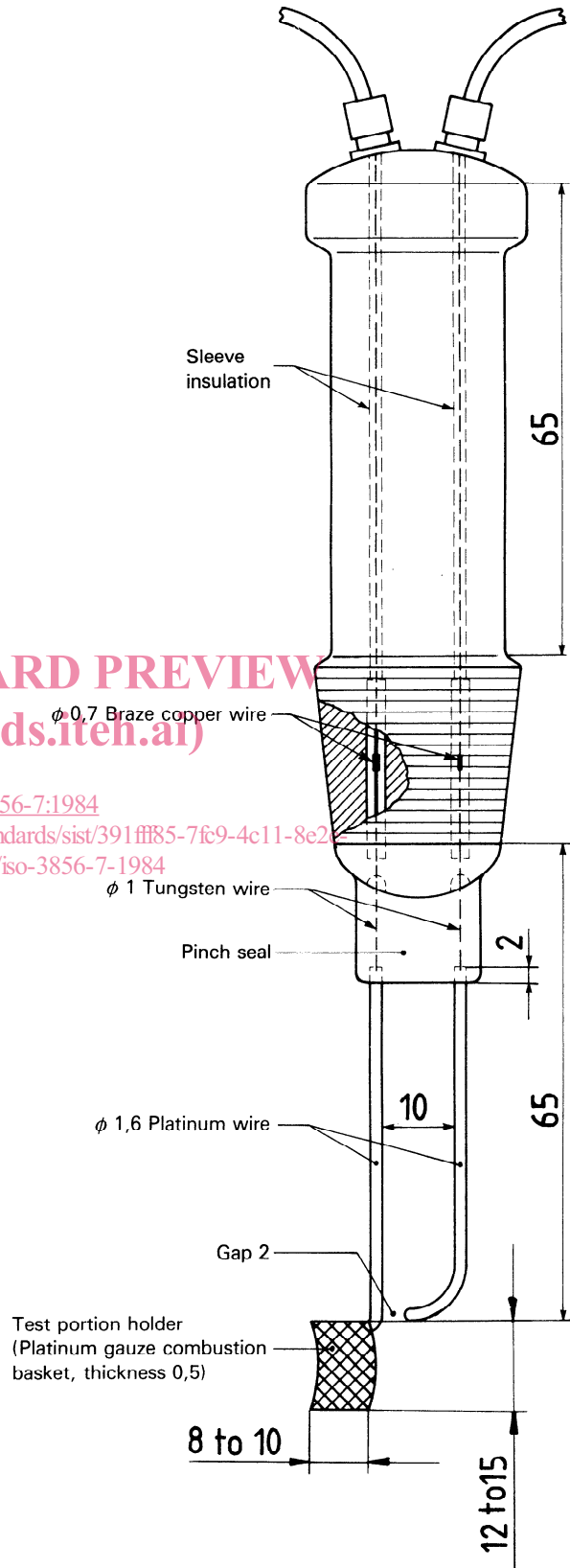

Figure 1 — Firing adapter

1) Not required for paints in powder form (see clause 7 of ISO 6713).

a is flexible tubing (5.12)

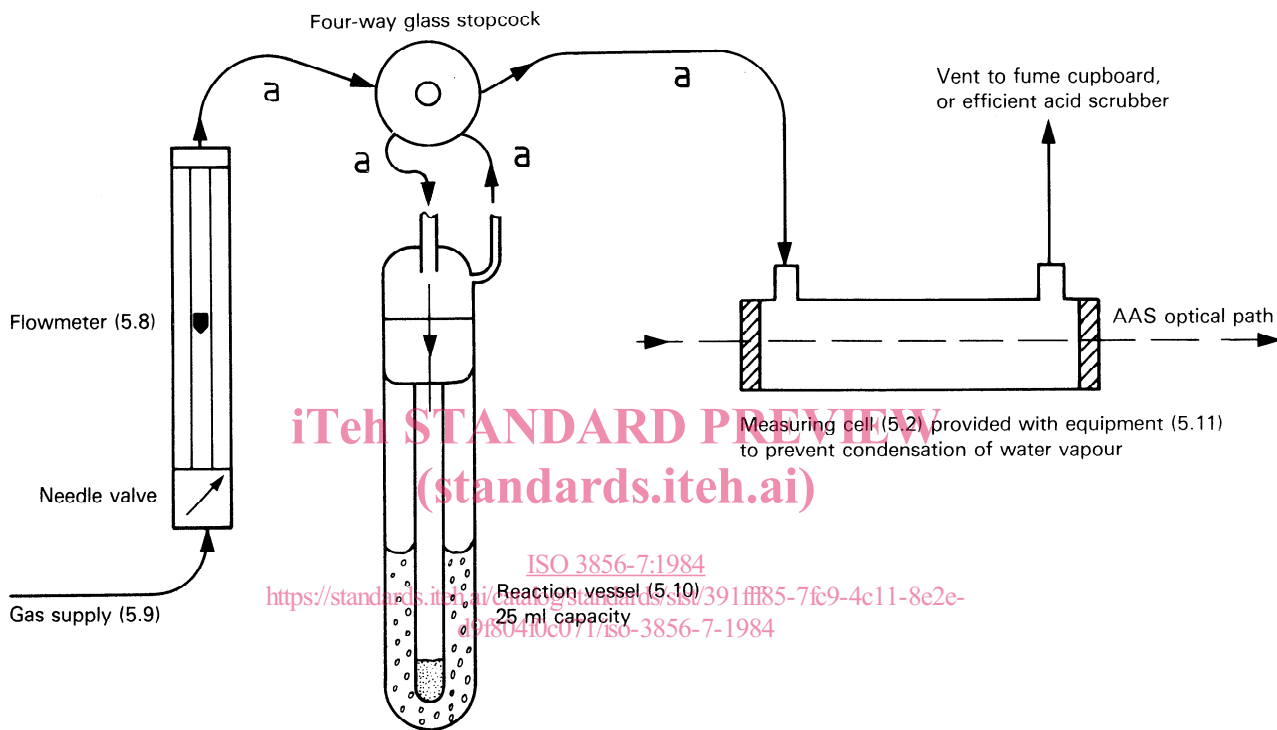

Figure 2 — Example of apparatus for the determination of mercury by flameless atomic absorption spectrometry