



Designation: C12 – 16

# Standard Practice for Installing Vitrified Clay Pipe Lines<sup>1</sup>

This standard is issued under the fixed designation C12; the number immediately following the designation indicates the year of original adoption or, in the case of revision, the year of last revision. A number in parentheses indicates the year of last reappraisal. A superscript epsilon (ε) indicates an editorial change since the last revision or reappraisal.

*This standard has been approved for use by agencies of the U.S. Department of Defense.*

## 1. Scope

1.1 This practice covers the proper methods of installing vitrified clay pipe lines in order to fully utilize the structural properties of such pipe.

1.2 The values stated in inch-pound units are to be regarded as standard. The values given in parentheses are mathematical conversions to SI units that are provided for information only and are not considered standard.

1.3 *This standard does not purport to address all of the safety concerns, if any, associated with its use. It is the responsibility of the user of this standard to establish appropriate safety and health practices and determine the applicability of regulatory limitations prior to use.*

## 2. Referenced Documents

2.1 *ASTM Standards:*<sup>2</sup>

- C301 Test Methods for Vitrified Clay Pipe
- C403/C403M Test Method for Time of Setting of Concrete Mixtures by Penetration Resistance
- C425 Specification for Compression Joints for Vitrified Clay Pipe and Fittings
- C700 Specification for Vitrified Clay Pipe, Extra Strength, Standard Strength, and Perforated
- C828 Test Method for Low-Pressure Air Test of Vitrified Clay Pipe Lines
- C896 Terminology Relating to Clay Products
- C1091 Test Method for Hydrostatic Infiltration Testing of Vitrified Clay Pipe Lines
- D2487 Practice for Classification of Soils for Engineering Purposes (Unified Soil Classification System)
- D2488 Practice for Description and Identification of Soils (Visual-Manual Procedure)

<sup>1</sup> This practice is under the jurisdiction of ASTM Committee C04 on Vitrified Clay Pipe and is the direct responsibility of Subcommittee C04.20 on Methods of Test and Specifications.

Current edition approved May 15, 2016. Published May 2016. Originally approved in 1915. Last previous edition approved in 2014 as C12 – 14. DOI: 10.1520/C0012-16.

<sup>2</sup> For referenced ASTM standards, visit the ASTM website, www.astm.org, or contact ASTM Customer Service at service@astm.org. For *Annual Book of ASTM Standards* volume information, refer to the standard's Document Summary page on the ASTM website.

- D4832 Test Method for Preparation and Testing of Controlled Low Strength Material (CLSM) Test Cylinders
- D5821 Test Method for Determining the Percentage of Fractured Particles in Coarse Aggregate
- D6103 Test Method for Flow Consistency of Controlled Low Strength Material (CLSM) (Withdrawn 2013)<sup>3</sup>

## 3. Terminology

3.1 *General*—Terminology C896 can be used for clarification of terminology in this specification.

3.2 See Fig. 1.

## DESIGN CONSIDERATIONS

### 4. Supporting Strength

4.1 The field supporting strength of vitrified clay pipe is materially affected by the methods of installation. The field supporting strength of a pipe is defined as its capacity to support dead and live loads under actual field conditions. It is dependent upon two factors: (1) the inherent strength of the pipe and (2) the bedding of the pipe.

4.2 The minimum bearing strength requirement in accordance with Specification C700, as determined by the 3-edge-bearing test of Test Methods C301, is a measure of the inherent strength of the pipe.

4.3 The tests used to measure bearing strength determine relative pipe strengths but do not represent actual field conditions. Therefore, an adjustment called a load factor is introduced to convert minimum bearing strength to field supporting strength. The magnitude of the load factor depends on how the pipe is bedded. The relationship is:

$$\text{Field supporting strength} = \text{minimum bearing strength} \times \text{load factor}$$

4.4 A factor of safety >1.0 and ≤1.5 shall be applied to the field supporting strength to calculate a safe supporting strength. The relationship is:

$$\text{Safe supporting strength} = \frac{\text{Field supporting strength}}{\text{Factor of safety}}$$

<sup>3</sup> The last approved version of this historical standard is referenced on www.astm.org.

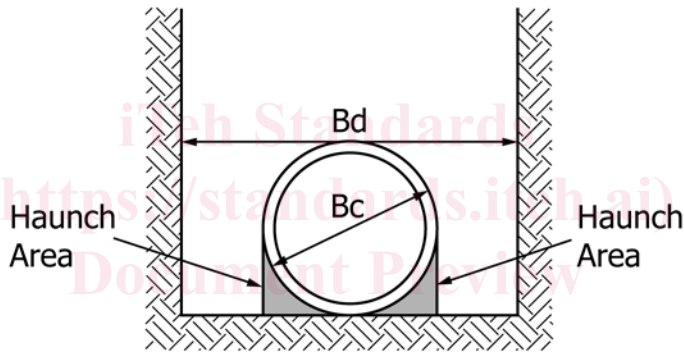
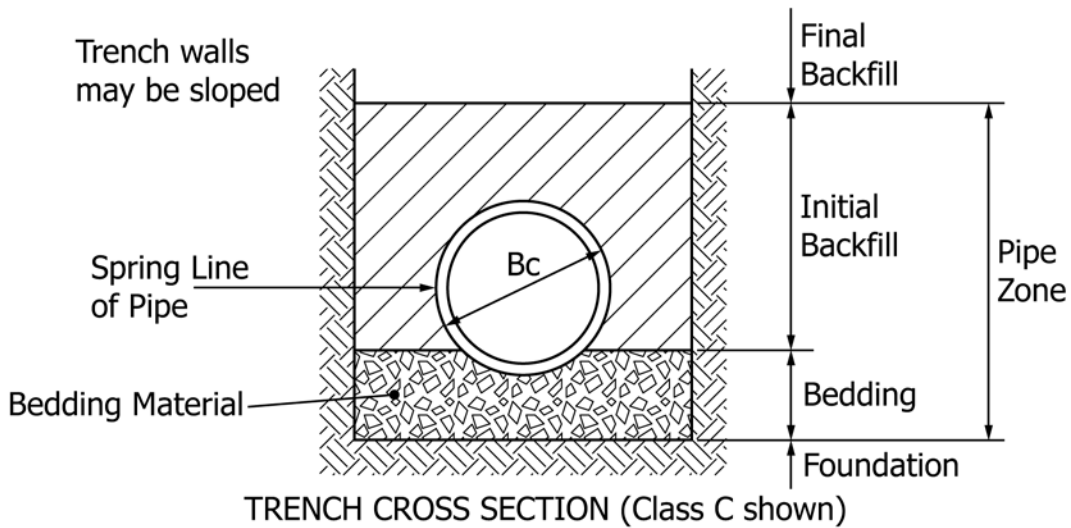

$B_c$  = the outside diameter of the pipe barrel.  
 $B_d$  = the design trench width measured at the horizontal plane at the top of the pipe barrel.

FIG. 1 Terminology

## 5. External Loads

5.1 The external loads on installed vitrified clay pipe are of two general types: (1) dead loads and (2) live loads.

5.2 For pipes installed in trenches at a given depth, the dead load increases as the trench width, measured at the top of the pipe, increases. Pipe failure may result if the design trench width is exceeded. If the trench width exceeds the design width, a higher class of bedding, stronger pipe, or both, must be investigated.

5.3 Live loads that act at the ground surface are partially transmitted to the pipe. Live loads may be produced by wheel loading, construction equipment or by compactive effort. Compaction of embedment and backfill materials, beside and above the sewer pipe, produces a temporary live load on the pipe. The magnitude of the live load from compactive effort varies with soil type, degree of saturation, degree of compac-

tion and depth of cover over the pipe. Care must be used in selection of compaction methods so that the combined dead load and live load does not exceed the field supporting strength of the pipe, or cause a change in its line or grade.

NOTE 1—For generally accepted criteria and methods for determining loads and supporting strengths, see *Gravity Sanitary Sewer Design and Construction, Water Pollution Control Federation Manual of Practice No. FD-5, American Society of Civil Engineers—Manuals and Report on Engineering Practice—No. 60*.<sup>4</sup>

## 6. Bedding and Encasement

6.1 Classes of bedding and encasements for pipe in trenches are defined herein. The load factors indicated are for conversion of minimum bearing strength to field supporting strength.

<sup>4</sup> Available from American Society of Civil Engineers (ASCE), 1801 Alexander Bell Dr., Reston, VA 20191, <http://www.asce.org>.

6.1.1 The soil groups used in each bedding class are defined in **Table 1**.

6.1.2 The gradation for Class I and Class II soil for Class C bedding (**Fig. 3**) shall have a maximum particle size of 1 in. (25 mm).

6.1.3 The gradation for Class I and Class II bedding material for Class B (**Fig. 4**), Crushed Stone Encasement (**Fig. 5**), and CLSM installation (**Fig. 6**) shall be as follows:

- 100 % passing a 1 in. (25 mm) sieve
- 40-60 % passing a ¾ in. (19 mm) sieve
- 0-25 % passing a ⅜ in. (9.5 mm) sieve

6.1.4 For Class I, all particle faces shall be fractured.

6.1.5 Class II soils shall have a minimum of one fractured face. For Class B (**Fig. 4**), Crushed Stone Encasement (**Fig. 5**), and CLSM installations (**Fig. 6**) where high, or changing water tables, or both, are present; Class II material shall have a minimum percentage by particle count of one fractured face-100 %, two fractured faces-85 %, and three fractured faces-65 % in accordance with Test Method **D5821**.

6.1.6 Class I material is considered to be more stable and provide better support than Class II material that have some rounded edges.

6.1.7 All bedding material shall be shovel-sliced so the material fills and supports the haunch area and encases the pipe to the limits shown in the trench diagrams.

6.2 **Class D** (**Fig. 2**):

6.2.1 The pipe shall be placed on a firm and unyielding trench bottom with bell holes provided (**Fig. 7**).

6.2.2 The initial backfill shall be either Class I, II, III, or IV having a maximum particle size of 1 in. (25 mm).

6.2.3 The load factor for Class D bedding is 1.1.

6.3 **Class C** (**Fig. 3**):

6.3.1 The pipe shall be bedded in Class I or Class II soil. Refer to **6.1.2** and **Table 2** for requirements. Sand is suitable as a bedding material in a total sand environment, but may be unsuitable where high and rapidly changing water tables are present in the pipe zone. Sand may also be undesirable in a trench cut by blasting or in trenches through clay type soil. Regardless of the trench condition or bedding class, the maximum load factor for sand bedding is 1.5. The bedding shall have a minimum thickness beneath the pipe of 4 in. (100 mm) or one sixth of the outside diameter of the pipe, whichever is greater, and shall extend up the haunches of the pipe one sixth of the outside diameter of the pipe.

6.3.2 The initial backfill shall be either Class I, II, III, or IV having maximum particle size of 1-½ in. (38 mm) (see **Table 2**).

6.3.3 The load factor for Class C bedding is 1.5.

6.4 **Class B** (**Fig. 4**):

6.4.1 The pipe shall be bedded in Class I or Class II soil. Refer to **6.1.3**, **6.1.5**, and **Table 2** for requirements. The bedding shall have a minimum thickness beneath the pipe of 4 in. (100 mm) or one sixth of the outside diameter of the pipe, whichever is greater, and shall extend up the haunches of the pipe to the springline.

6.4.2 The initial backfill shall be either Class I, II, III, or IV having a maximum particle size of 1-½ in. (38 mm).

6.4.3 The load factor for Class B bedding is 1.9.

6.5 **Crushed Stone Encasement** (**Fig. 5**):

6.5.1 The pipe shall be bedded in Class I or Class II soil. Refer to **6.1.3**, **6.1.5**, and **Table 2** for requirements. The bedding shall have a minimum thickness beneath the pipe of 4 in. (100 mm) or one sixth of the outside diameter of the pipe, whichever is greater, and shall extend upward to a horizontal

ASTM C12-16

<https://standards.iteh.ai/catalog/standards/sist/9ea04543-5c4d-45de-b19b-e92c093894d2/astm-c12-16>

**TABLE 1 Uniform Soil Groups for Pipe Installation**

NOTE 1—Soil Classification descriptions and symbols are in accordance with Practice **D2487** and Practice **D2488**.

NOTE 2—For Class I, all particle faces shall be fractured.

NOTE 3—Materials such as broken coral, shells, slag, and recycled concrete (with less than 12 % passing a #200 sieve) should be treated as Class II soils.

NOTE 4—Class V soil is not suitable for use as a bedding or initial backfill material.

<b>Class I</b>	<b>crushed rock</b> 100 % passing 1-½ in. (38 mm) sieve, <= 15 % passing #4 sieve, <= 25 % passing ⅝ in. (9.5 mm) sieve, <= 12 % passing #200 sieve	
<b>Class II</b>	<b>clean, coarse grained soils</b> or any soil beginning with one of these symbols (can contain fines up to 12 %) uniform fine sands (SP) with more than 50 % passing a #100 sieve should be treated as Class III material	<b>GW, GP, SW, SP</b>
	<b>coarse grained soils with fines</b> or any soil beginning with one of these symbols	<b>GM, GC, SM, SC</b>
<b>Class III</b>	<b>sandy or gravelly fine grained soils</b> or any soil beginning with one of these symbols with >= 30 % retained on #200 sieve	<b>ML, CL</b>
<b>Class IV</b>	<b>fine-grained soils</b> or any soil beginning with one of these symbols with <30 % retained on #200 sieve	<b>ML, CL</b>
<b>Class V</b>	<b>fine-grained soils, organic soils</b> high compressibility silts and clays, organic soil	<b>MH, CH, OL, OH, Pt</b>

Trench Walls  
may be sloped

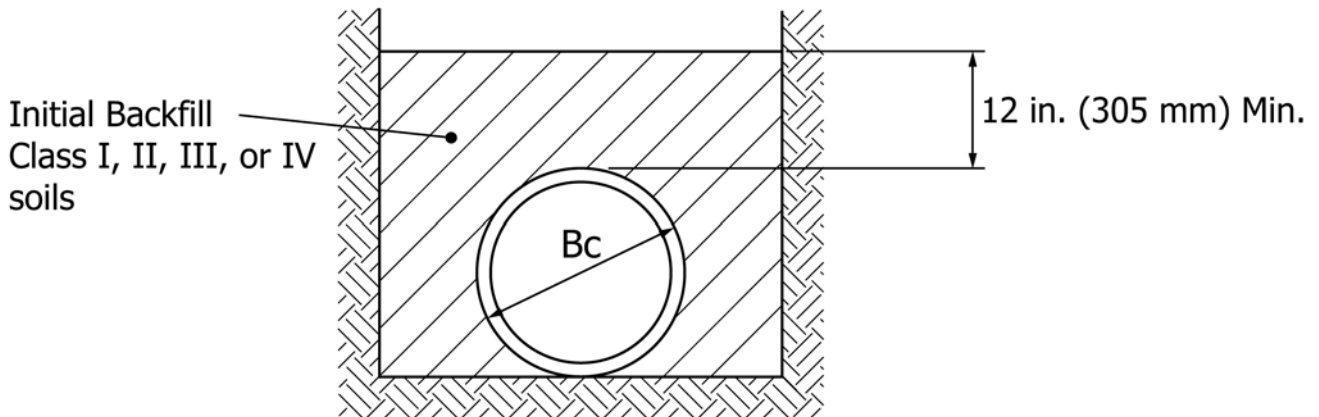

Load Factor 1.1

FIG. 2 Class D

Trench walls  
may be sloped

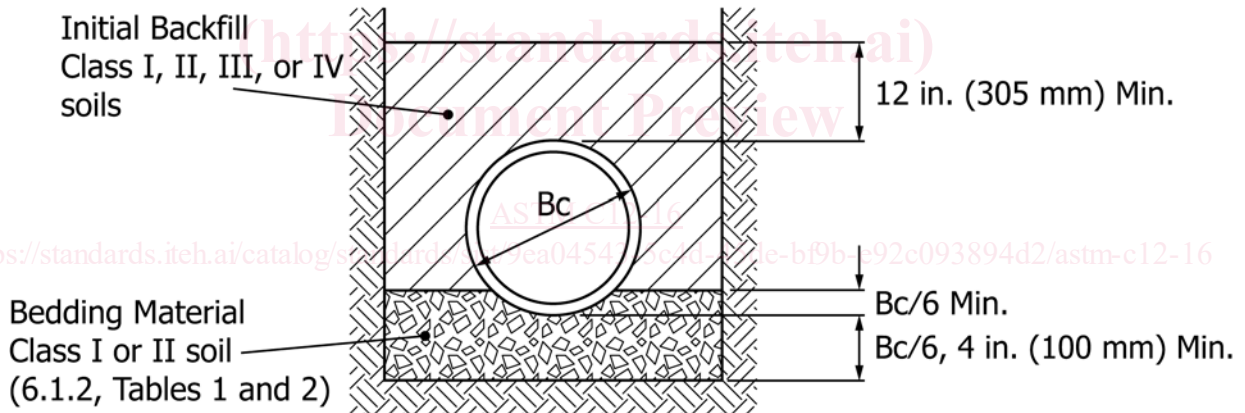

Load Factor 1.5

FIG. 3 Class C

plane at the top of the pipe barrel. Material shall be carefully placed into the pipe haunches.

6.5.2 Sufficient material shall be placed so that the bedding extends to a horizontal plane at the top of the pipe barrel following removal of any trench sheeting or boxes.

6.5.3 The initial backfill shall be either Class I, II, III, or IV having a maximum particle size of 1-1/2 in. (38 mm).

6.5.4 The load factor for crushed stone encasement is 2.2.

6.6 *Controlled Low Strength Material* (Fig. 6)—Controlled low strength material (CLSM) is used as an effective material for the bedding of vitrified clay pipe.

6.6.1 The pipe shall be bedded on Class I or Class II soil. Refer to 6.1.3, 6.1.5, and Table 2 for requirements. The

bedding shall have a minimum thickness beneath the pipe of 4 in. (100 mm) or one sixth of the outside diameter of the pipe, whichever is greater.

6.6.2 For pipe diameters 8 to 21 in. (205 to 535 mm), CLSM shall extend a minimum of 9 in. (230 mm) on each side of the pipe barrel. For pipe diameters 24 in. (610 mm) and larger, CLSM shall extend a minimum of 12 in. (305 mm) on each side of the pipe barrel (Fig. 6).

6.6.3 When placed, CLSM shall have a measured flowability of  $8 \pm 1$  in. ( $205 \pm 25$  mm) spread diameter as determined by Test Method D6103.

6.6.4 28-day compressive strength shall be 100 to 300 psi (0.69 to 2.07 MPa) as determined by Test Method D4832.