



Designation: ~~A341/A341M – 00 (Reapproved 2011)~~^{ε1} A341/A341M – 16

Standard Test Method for Direct Current Magnetic Properties of Soft Magnetic Materials Using D-C Permeameters and the Ballistic Point by Point (Ballistic) Test Methods¹

This standard is issued under the fixed designation A341/A341M; the number immediately following the designation indicates the year of original adoption or, in the case of revision, the year of last revision. A number in parentheses indicates the year of last reapproval. A superscript epsilon (ϵ) indicates an editorial change since the last revision or reapproval.

This standard has been approved for use by agencies of the U.S. Department of Defense.

^{ε1} NOTE—Corrected text and Fig. 1 editorially in December 2011.

1. Scope

1.1 This test method provides dc permeameter tests for the basic magnetic properties of soft magnetic materials in the form of bars, rods, wire, or strip specimens which may be cut, machined, or ground from cast, compacted, sintered, forged, extruded, rolled, or other fabricated materials. It includes tests for determination of the normal induction under symmetrically cyclically magnetized (SCM) conditions and the hysteresis loop (B-H loop) taken under conditions of rapidly changing or steep wavefront reversals of the direct current magnetic field strength. This method has been historically referred to as the ballistic test method. For testing hard or permanent magnet materials, Test Method A977/A977M shall be used.

1.2 This test method shall be used in conjunction with Practice A34/A34M.

1.3 This test method covers a range of magnetic field strength in the specimen from about 0.05 Oe [4 A/m] up to above 5000 Oe [400 kA/m] through the use of several permeameters. The separate permeameters cover this test region in several overlapping ranges.

1.4 Normal induction and hysteresis properties may be determined over the magnetic flux density range from essentially zero to intrinsic saturation induction for most materials.

ASTM A341/A341M-16

¹ This test method is under the jurisdiction of ASTM Committee A06 on Magnetic Properties and is the direct responsibility of Subcommittee A06.01 on Test Methods. Current edition approved October 1, 2011; May 1, 2016. Published October 2011; May 2016. Originally approved in 1969. Last previous edition approved in 2005; 2011 as A341/A341M – 00(2005)(2011)^{ε1}. DOI: 10.1520/A0341-A0341M-00R1HE01-10.1520/A0341_A0341M-16.

TABLE 1 Permeameters

Permeameter	Useful Magnetic Field Strength Range ^A		H Measuring Device ^B	Reluctance Compensation	Magnetizing Coil Surrounds Specimen	References ^D
	Oe	kA/m				
Babbit	40/1000	3.2/80	I, HC	yes	yes	(1,2)
Burroughs	0.1/300	0.008/24	I	yes	yes	(1,3,4,5)
Fahy Simplex ^C	0.1/300	0.008/24	HC	no	no	(1,4,5,6,7)
Fahy Simplex Super H adapter ^C	100/2500	8/200	HC	no	no	(1,3)
Full range	0.05/1400	0.004/112	HC	yes	yes	(1,8)
High H	100/5000	8/400	FC	yes	no	(1,5,7,9)
Iliovici	0.5/500	0.04/400	I, HC	yes	yes	(4,10,11)
IEC Type A	0.1/2500	0.008/200	HC, HP	no	yes	IEC 60404-4
IEC Type B	0.1/630	0.008/50	RCC	no	no	IEC 60404-4
Isthmus	100/20 000+	8/1600+	HC, HP	no	no	(1,4,12,13)
MH	0.1/300	0.008/24	FC	yes	yes	(1,6,14)
NPL	0.5/2500	0.04/200	I, HC	yes	yes	(15)
Saturation	100/4000	8/320	HC	no	yes	(5,16,17)

^A Although the permeameters are capable of being used at the lower end of the measurement range, the measurement accuracy is reduced.

^B I—magnetizing current; HC—fixed H coil; FC—flip coil; HP—Hall probe; RCC—Rogowski-Chattock coil.

^C Fahy permeameters require a standard of known magnetic properties for calibration of the H coil.

^D The boldface numbers in parentheses refer to a list of references at the end of this standard.

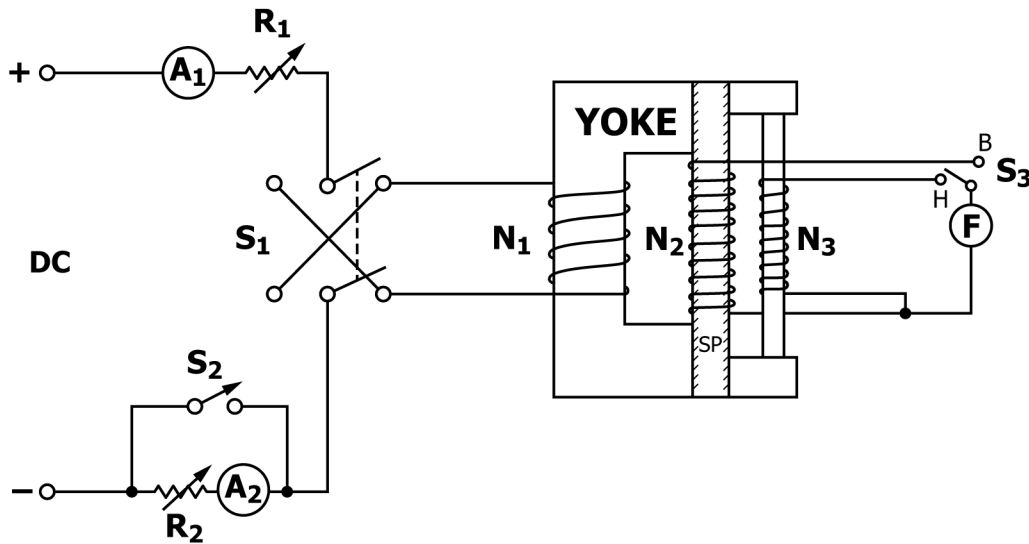

NOTE 1—

- A₁—Multirange ammeter (main current)
- A₂—Multirange ammeter (hysteresis current)
- B—Flux—Magnetic flux density test position for Switch S₃
- F—Electronic Integrator Fluxmeter
- H—Magnetic field strength test position for Switch S₃
- N₁—Magnetizing coil
- N₂—Flux—Magnetic flux sensing (B) coil
- N₃—Magnetic field strength (H) sensing coil
- R₁—Main current control rheostat
- R₂—Hysteresis current control rheostat
- S₁—Reversing switch for magnetizing current
- S₂—Shunting switch for hysteresis current control rheostat
- S₃—Integrator—Fluxmeter selector switch
- SP—Specimen

FIG. 1 Basic Circuit Using Permeameter

ASTM A341/A341M-16

1.5 Recommendations of the useful magnetic field strength range for each of the permeameters are shown in **Table 1**.² Permeameters particularly well suited for general testing of soft magnetic materials are shown in boldface. Also, see Sections 3 and 4 for general limitations relative to the use of permeameters.

1.6 The symbols and abbreviated definitions used in this test method appear with **Fig. 1** and in appropriate sections of this document. For the official definitions, see Terminology **A340**. Note that the term magnetic flux density used in this document is synonymous with the term magnetic induction.

1.7 **Warning**—Mercury has been designated by EPA and many state agencies as a hazardous material that can cause central nervous system, kidney, and liver damage. Mercury, or its vapor, may be hazardous to health and corrosive to materials. Caution should be taken when handling mercury and mercury-containing products. See the applicable product Material Safety Data Sheet (MSDS) for details and EPA's website (<http://www.epa.gov/mercury/faq.htm>) for additional information. Users should be aware that selling mercury or mercury-containing products, or both, in your state may be prohibited by state law.

1.8 The values and equations stated in customary egs-emu (cgsg-emu and inch-pound) or SI units are to be regarded separately as standard. Within this standard, SI units are shown in brackets except for the sections concerning calculations where there are separate sections for the respective unit systems. The values stated in each system may not be exact equivalents; therefore, each system shall be used independently of the other. Combining values from the two systems may result in nonconformance with this standard.

1.9 *This standard does not purport to address all of the safety concerns, if any, associated with its use. It is the responsibility of the user of this standard to establish appropriate safety and health practices and determine the applicability of regulatory limitations prior to use.*

² The boldface numbers in parentheses refer to a list of references at the end of this standard.



2. Referenced Documents

2.1 ASTM Standards:³

A34/A34M Practice for Sampling and Procurement Testing of Magnetic Materials

A340 Terminology of Symbols and Definitions Relating to Magnetic Testing

A596/A596M Test Method for Direct-Current Magnetic Properties of Materials Using the Ballistic Method and Ring Specimens

A977/A977M Test Method for Magnetic Properties of High-Coercivity Permanent Magnet Materials Using Hysteresigraphs

2.2 IEC Standard:

Publication 60404-4, Ed. 2:02.2 Magnetic Materials – Part 4: Methods of Measurement of D.C. Magnetic Properties of Iron and Steel, IEC, 1995 Plus Amendments 1 in 2000 and 2 in 2008⁴

2.3 Other Documents:

NIST Circular No. 74, pg. 269⁵

NIST Scientific Paper 117, SPBTA⁵

3. Significance and Use

3.1 Permeameters require the use of yokes to complete the magnetic circuit and are therefore inherently less accurate than ring test methods. Refer to Test Method A596/A596M for further details on ring test methods. However, when testing certain shapes as bars or when magnetic field strength in excess of 200 Oe [~~15.9 or more kA/m~~] are [16 kA/m] is required, permeameters are the only practical means of measuring magnetic properties.

3.2 This test method is suitable for specification acceptance, service evaluation, research and development and design.

3.3 When the test specimen is fabricated from a larger sample and is in the same condition as the larger sample, it may not exhibit magnetic properties representative of the original sample. In such instances the test results, when viewed in context of past performance history, will be useful for judging the suitability of the material for the intended application.

4. Interferences

4.1 In general, permeameters do not maintain a uniform magnetic field in either the axial or radial directions around the test specimen. The field gradients in both of these directions will differ in the various permeameters. Also the H -sensing and B -sensing coils of the different permeameters are not identical in area, in turns, or in length or identically located. Although test specimens are prepared to have uniform physical cross section, they may have undetected nonuniform magnetic properties radially or axially along the specimen length adjacent to the H or B coils. Some permeameters may also introduce clamping strains into the test specimen. For the above reasons test results obtained on a test specimen with one type permeameter may not agree closely with those obtained on the same test specimen using another type of permeameter.

5. Apparatus

5.1 Because of the differences in physical construction of the various permeameters listed in Table 1, no standard list of components is given. When used with a particular type of permeameter, the components should conform to the general requirements listed below. A basic schematic of a permeameter is shown in Fig. 1.

5.2 *Permeameter*—The particular permeameter used shall be of high quality construction. The yokes should be made of high permeability alloy such as oriented or nonoriented silicon iron or nickel-iron alloy, although low carbon steel or iron is acceptable in certain instances. The preferred yoke dimensions are listed in the appended references (see Table 1). Deviations from these dimensions should be such that the yoke is operating at or below the point of maximum permeability for the highest test magnetic flux densities encountered. Yoke construction may consist of either stacked laminations or stripwound C cores suitably bolted or adhesive bonded together.

5.3 *Power Supply*—The magnetizing current shall be supplied by either storage batteries or dc power supplies. Bipolar programmable linear power supplies have been found to be well suited for this use. The source of dc current must be stable, have negligible ripple and be capable of quickly returning to the stable state after switching. When programmable power supplies are used, either digital or analog programming signals are permissible provided that equal but opposite polarity current cycling is possible.

5.4 *Main-Current-Control Rheostats, R_J* —When used, these rheostats must have sufficient power rating and heat-dissipating capacity to handle the voltage and largest test current and must contain provide sufficient resistance to limit the test currents to those required for the lowest magnetic field strength to be used.

³ For referenced ASTM standards, visit the ASTM website, www.astm.org, or contact ASTM Customer Service at service@astm.org. For Annual Book of ASTM Standards volume information, refer to the standard's Document Summary page on the ASTM website.

⁴ Available from American National Standards Institute (ANSI), 25 W. 43rd St., 4th Floor, New York, NY 10036.

⁵ Available from National Institute of Standards and Technology (NIST), 100 Bureau Dr., Stop 1070, Gaithersburg, MD 20899-1070, http://www.nist.gov.



5.5 *Hysteresis-Current-Control Rheostats, R_2* —When used, these rheostats must have the same characteristics as the main-current control rheostats.

5.6 *Main-Current Ammeter, A_1* —Magnetizing current measurement shall be conducted using a digital ammeter or combination of a digital voltmeter and precision ~~shunt-current sensing~~ resistor with an overall accuracy of better than 0.25 % when the magnetic field strength will be determined from the current. In those permeameters where the magnetic field strength is determined by other means, such as Hall probes or H coils, lower accuracy analog instruments can be used. In such permeameters, the ammeter is used to prevent excessive currents from being applied and, based on past experience, to roughly establish the required magnetic field strength.

5.7 *Hysteresis-Current Ammeter, A_2* —The requirements of 5.6 shall apply. In general, a separate ammeter is not required.

5.8 *Reversing Switch, S_1* —When nonprogrammable dc current sources such as storage batteries are used, a current reversing switch is required. The reversing switch should be either a high quality knife switch, mechanical or electrical solenoid-operated contractors or mercury switches having high current rating and the ability to maintain uniform contact resistance of equal magnitude in both current directions. Switches with contact bounce or other multiple contacting behavior on make or break must be avoided. Because of the presence of leakage currents in the open condition, solid state relays are not permitted.

5.9 *Hysteresis Switch, S_2* —This single pole switch must conform to the same requirements as the reversing Switch, S_1 .

5.10 *Integrator, Fluxmeter, F* —Because of their superior accuracy, stability, and ease of operation, electronic ~~charge integrators~~ are the preferred means of measuring magnetic flux. ~~Integrators fluxmeters~~ shall be used to measure the magnetic flux density and, if an H-coil is used, the magnetic field strength. Fluxmeters using either operational amplifier and capacitor feedback (analog integrator) or ~~pulse counting—~~analog to digital conversion and digital integration are permitted. The accuracy of the ~~integrator fluxmeter~~ must be better than 1 % full scale. If analog display meters are used to read the value of magnetic flux, the measurement should be made on the upper two-thirds of the scale. Analog ~~integrators fluxmeters~~ must have drift adjust circuitry and the drift should not exceed 100 ~~Maxwell-turns~~maxwell-turns [10^{-6} Wb-turns] per minute on the most sensitive range. It is also desirable that the ~~integrator fluxmeter~~ have appropriate scaling circuitry to permit direct reading of either magnetic flux (ϕ) or magnetic flux density (B). ~~Ballistic galvanometers or moving coil fluxmeters~~ are permitted provided the 1 % full-scale accuracy requirement is met. Such devices require additional circuitry not shown in Fig. 1. Details may be found in the appropriate references appended to this test method.

5.11 *B Coils*—Prewound fixed magnetic flux sensing coils are often used. When used, the cross-sectional area enclosed by the secondary winding and number of turns must each be known to within 0.5 %.

5.12 *Magnetic Field Strength Measuring Devices*—Certain permeameters do not or cannot use the magnetizing current to determine the magnetic field strength accurately. Such permeameters instead use stationary H coils, flip coils, or Hall probes. When such devices are used, they shall be capable of determining the ~~apparent~~ magnetic field strength to accuracy of 1.0 % or better.

6. Test Specimens

6.1 Test specimen area shall normally be determined from mass, length, and density as indicated in 9.1 and 10.1. When the test specimen is machined or ground to have a very smooth surface, the physical dimensions obtained from micrometer measurements may be used to calculate the cross-sectional area.

6.2 Test specimens in bar form may be of round, square, or rectangular cross-sectional shape. In some permeameters the bar specimen may be a half round or any shape having a uniform cross-sectional area. Certain permeameters must have a good magnetic joint between the ends of the test specimen and the permeameter yoke or pole faces. Pole shoes may be necessary to create this joint. Generally, to achieve a good magnetic joint, the test specimen must be of square or rectangular cross section and must be machined or ground to have straight and parallel surfaces. For permeameters using specimens butted to pole pieces, the specimen ends must be smooth and parallel.

6.3 When the material is in flat-rolled form and is to be evaluated as half transverse-half longitudinal, the specimen shall be sheared to have strips in ~~multiples of four~~ in accordance with Table 2, ~~except that multiples of four are not required~~. When material is to be evaluated in one direction, it shall conform to this table or to the requirements for best test quality in a particular permeameter. For ~~gages No. 33 and thinner, strip and sheet less than 0.0100 in. [0.254 mm] in thickness,~~ the cross-sectional area shall be not less than 0.31 in.² [200 mm²] and not more than 0.62 in.² [400 mm²].

6.4 When the test specimen for strip materials is to be half transverse and half longitudinal, the ~~strips shall be positioned to be composed of alternately transverse and longitudinal throughout the specimen and a transverse strip shall be placed adjacent to the permeameter's yoke or pole face.~~ preferred method is to test the transverse strips as one specimen and the longitudinal strips as another specimen. ~~Mixing the specimens when significant magnetic anisotropy is present could result in unrealistic test results.~~

6.5 For full testing accuracy, the length and size of the test specimen must meet the requirements of the permeameter being used. Generally, for most permeameters, a test specimen length of 10 in. [0.254 [0.25 m] or more is required. Shorter specimens with some permeameters will require the use of pole-piece extensions, and may cause a reduction in testing accuracy. Other permeameters are designed for short specimens without loss of testing accuracy.



TABLE 2 Number of Test Strips

Nominal Thickness		Gage Number	Number of Strips
in.	mm		
0.0100 to 0.0250	0.254 to 0.635	32 to 24, incl	12
0.0280 to 0.0435	0.711 to 1.105	23 to 19, incl	8
0.0500 and over	1.27 and over	18 and thicker	4

TABLE 2 Number of Test Strips

Nominal Thickness		Number of Strips
in.	mm	
0.0100 to 0.0250	0.254 to 0.635	12
0.0280 to 0.0435	0.711 to 1.105	8
0.0500 and over	1.27 and over	4

6.6 All test specimen forms shall be cut, machined, or ground to have a uniform cross-sectional area along the active length of the test specimen. The cross-sectional area shall be sufficiently uniform so that its nonuniformity will not materially affect the accuracy of establishing and measuring magnetic flux density in the test sample.

6.7 When required for development of material properties the test specimen shall have received a stress relief or other heat treatment after preparation. This anneal is subject to agreement between ~~manufacturer~~ producer and ~~purchaser~~ user; producer's recommendation; or the recommended heat treatment provided by the appropriate ASTM standard for the material. The heat treatment used shall be reported with the ~~magnitude test results~~ test results as indicated in [11.1.3](#).

6.8 ~~Specimens of permanent magnetic materials shall be processed before testing in accordance with a procedure acceptable to both manufacturer and purchaser. The processing used shall be reported with the test results.~~

7. Calibration

7.1 ~~Integrator—Fluxmeter~~—Practical operating experience has shown that provided a proper warmup period is allowed, electronic ~~integrators~~ fluxmeters require infrequent calibration and ~~unlike ballistic galvanometers, therefore calibration is not an integral part of this test method.~~ When calibration is required, it can be accomplished with either a mutual inductor or a volt-second source. Because of their traceability to the fundamental units of voltage and time, volt-second sources are the preferred means of calibration. The accuracy of either the mutual inductor or volt-second source must be better than the rated full scale accuracy of the ~~integrator~~ fluxmeter.

7.2 ~~Fixed B and H Coils~~—The effective area turns of such search coils can be determined by comparison with a coil of known area turns or by individual calibration in a series of known magnetizing fields. Such fields can be obtained using either long ~~solenoid electromagnets~~ solenoids ~~electromagnets~~ or large appropriate Helmholtz coil systems.

7.3 ~~Comparison Permeameters~~—Certain types of permeameters such as the Fahy permeameter require a standard specimen of known magnetic properties to derive the relationship between field sensor output and true magnetic field strength. ~~Instead~~ In the absence of nationally recognized standard specimens, a standard may be developed by mutual agreement between ~~manufacturer~~ producer and ~~purchaser~~ user, and if possible, a referee laboratory.

8. Procedure

8.1 ~~Most~~ Many permeameters use a compensating system of magnetizing coils to provide extra magnetomotive force to overcome the reluctance of the yokes and joints in the magnetic circuit. Hence, the detailed operation procedure will vary somewhat with the type of permeameter used. Detailed operating procedures can be found in the references appended to this test method. The procedure listed below is common to all types of permeameters.

8.2 In [Fig. 1](#), the dc power source supplies testing current measured by ammeter A_1 or A_2 . Rheostats R_1 and R_2 and Switches S_1 and S_2 determine the magnitude and direction of the current as required by various operations. In general, three kinds of switching operations are ~~required in ballistic testing.~~ One is reversal of magnetizing current direction without change of magnitude as required for establishing a cyclic condition and in normal magnetic tests. This is done by ~~throwing Switch~~ required, S_1 from one side to another. A second is reduction of magnitude of magnetizing current without change of direction. This is done by opening Switch S_2 . The third operation combines reversal of direction of magnetizing current with reduction in magnitude. This is done by simultaneously throwing Switch S_1 from one side to the other and opening Switch S_2 . Use care to be sure S_2 is opened before S_1 is closed for reversal. When determining the hysteresis loop, Switches S_1 and S_2 must be operated to traverse the loop in the same direction between successive measurements so as to preserve the cyclically magnetized state of the test specimen.

8.2.1 The first operation is the reversal of the magnetizing current direction without change in its magnitude as required for establishing a symmetrically cyclically magnetized condition used in determination of the normal induction curve. This is done by throwing Switch S_1 from one side to another. Normally this current reversal is done several times until a stable reading on the



fluxmeter is obtained. Since the fluxmeter reads only the change in flux linkages or flux density depending on how it is scaled, this is the key switching operation since it establishes the reference point for all subsequent measurements of magnetic flux density and magnetic field strength.

8.2.2 The second operation is the reduction of the magnitude of magnetizing current without change of direction. This is done by opening Switch S_2 . This allows for the measurement of the first quadrant of the hysteresis loop. If the fluxmeter is zeroed before opening Switch S_2 and the fluxmeter is calibrated to read magnetic flux density for the specimen, the resulting value is the difference between the maximum flux density (B_m) and the value of magnetic flux density corresponding to the magnetic field strength established by the hysteresis control rheostat R_2 . Note that prior to making the next measurement, the maximum magnetic flux density must be reestablished by closing Switch S_2 and cycling Switch S_1 several times always ending at the same polarity.

8.2.3 The third operation combines reversal of direction of magnetizing current with reduction in magnitude. This switching operation is required to measure points on the hysteresis loop in the second and third quadrants. This is done by simultaneously throwing Switch S_1 from one side to the other and opening Switch S_2 . Use care to be sure S_2 is opened before S_1 is closed for reversal. When determining the hysteresis loop, Switches S_1 and S_2 must be operated to traverse the loop in the same direction between successive measurements so as to preserve the cyclically magnetized state of the test specimen.

8.2.4 The usual practice for measuring the hysteresis loop is to measure the first and second quadrant and assume symmetry to complete the construction of the loop.

8.3 Before testing, demagnetize the specimen in the permeameter or by some other acceptable means. Demagnetize by first establishing a magnetic field strength sufficiently large to cause the magnetic flux density in the test specimen to reach a point well above the knee of the magnetization curve. Then while continuously operating the reversing switch at half-second or longer intervals, slowly reduce the magnetizing current to zero in small increments. An auxiliary demagnetizing circuit using a time delay relay will make this operation more reproducible and less tedious.

NOTE 1—Due to the inhomogeneous nature of permeameter magnetic circuits and the varying resolution of current control among different test systems, complete demagnetization of the test specimen (that is, $B = 0$ at $H = 0$) is seldom achievable. Provided the residual induction (B_r) in the specimen after demagnetization is less than 20 % of the lowest test magnetic flux density, the specimen can be considered to be demagnetized.

8.4 To obtain the magnetic flux density (B) corresponding to a specific magnetic field strength (H), establish the proper magnetic field strength, strength (including the proper hysteresis current if appropriate), cycle the reversing switch several times to establish the symmetrically cyclically magnetized (SCM) condition, zero the integrator fluxmeter and execute the proper switching procedure detailed in 8.2. The value of the magnetic flux or magnetic flux density can then be computed from the integrator fluxmeter reading. Additional test points on the magnetization curve can be obtained without demagnetization if they are obtained in ascending order of B or H . Otherwise, it is necessary to demagnetize before additional testing. It is not necessary to demagnetize provided the maximum magnetic field strength is well above the knee of the magnetization curve.

8.5 To obtain the magnetic field strength corresponding to a specific magnetic flux density, a procedure similar to 8.4 is used with the exception that the magnetic field strength must be found by trial and error. If the specified magnetic flux density is exceeded, demagnetization is usually required before proceeding further unless operating at very low magnetic flux densities.

8.6 Electronic integrator fluxmeters do not determine magnetic flux densities directly, rather the change in magnetic flux linkages ($N_2\Delta\phi$) is measured. This result is converted to changes in magnetic flux density by division by the specimen cross-sectional area A and number of secondary turns N_2 . To determine the actual value of magnetic flux density, the starting or reference points must be known. In the case of magnetization curve measurements, it is customary to zero the integrator fluxmeter and measure the change in magnetic flux density for a fully reversed change in magnetic field strength. In this instance, the true value of magnetic flux density is one half of the total change in magnetic flux density. For hysteresis loop determination, the integrator fluxmeter is zeroed at the point of maximum magnetic field strength. The resulting change in magnetic flux density is equal to the difference in magnetic flux density between the point of maximum magnetization force-magnetic field strength and the point corresponding to the hysteresis loop measurement magnetic field strength.

9. Calculation (Modified cgs (Customary Units))

9.1 The sample cross-sectional area shall normally be determined from test specimen mass, length, and density using the equation:

$$A = m/\delta l \quad (1)$$

where:

- A = cross-sectional area, cm^2 ;
- m = mass of specimen, g;
- δ = density of material, g/cm^3 ; and
- l = specimen length, cm.

9.2 In permeameters using a fixed B coil, the B coil cross-sectional area is often much larger than the test specimen cross-sectional area; when this occurs, a correction for air flux in the B coil is required. This correction shall be made as shown in 9.2.1 through 9.2.3.