



Designation: F2162 – 01 (Reapproved 2016)

Standard Specification for Bearing, Roller, Needle: Drawn Outer Ring, Full Complement, Without Inner Ring, Open and Closed End, Standard Type¹

This standard is issued under the fixed designation F2162; the number immediately following the designation indicates the year of original adoption or, in the case of revision, the year of last revision. A number in parentheses indicates the year of last reapproval. A superscript epsilon (ϵ) indicates an editorial change since the last revision or reapproval.

This standard has been approved for use by agencies of the U.S. Department of Defense.

1. Scope

1.1 This specification covers standard-type needle roller bearings having drawn outer rings, full complement, without inner rings, with either open or closed ends.

1.2 The use of recycled materials that meet the requirements of the applicable material specification without jeopardizing the intended use of the item is encouraged.

1.3 The inner rings specified in this specification are not intended for use in flight critical systems of aircraft.

1.4 The values stated in inch-pound units are to be regarded as standard. The values given in parentheses are mathematical conversions to SI units that are provided for information only and are not considered standard.

NOTE 1—This specification contains many of the requirements of MS17131, which was originally developed by the Department of Defense and is currently maintained by the Defense Supply Center Richmond.

2. Referenced Documents

2.1 ASTM Standards:²

E18 Test Methods for Rockwell Hardness of Metallic Materials

E140 Hardness Conversion Tables for Metals Relationship Among Brinell Hardness, Vickers Hardness, Rockwell Hardness, Superficial Hardness, Knoop Hardness, Scleroscope Hardness, and Leeb Hardness

E384 Test Method for Microindentation Hardness of Materials

F2163 Specification for Ring, Bearing, Inner: for Needle Roller Bearing With Drawn Outer Ring

2.2 ASME Standard:

ASME B 46.1 Surface Texture Surface Roughness, Waviness, and Lay³

2.3 SAE Standard:

SAE J-404 Chemical Composition of SAE Alloy Steels⁴

2.4 Military Standard:

MIL-STD-130 Identification Marking of US Military Property⁵

2.5 American Bearing Manufacturer's Association (ABMA) Standard:

STD 4 Tolerance Definitions and Gauging Practices For Ball and Roller Bearings⁶

2.6 ISO Standards:

ISO 5593 Rolling Bearings—Vocabulary⁷

ISO 1132 Rolling Bearings—Tolerances—Definitions⁷

3. Terminology

3.1 *Definitions*—For definitions of terms used in this specification, refer to ABMA STD 4 Tolerance Definitions and Gauging Practices for Ball and Roller Bearings, ISO 1132 Rolling Bearings—Tolerances—Definitions, and to ISO 5593 Rolling Bearings—Vocabulary

3.2 *Definitions of Terms Specific to This Standard:*

3.2.1 *average life (L_{50}), n*—for a radial roller bearing, the number of revolutions that 50 % of a group of bearings will complete or exceed before the first evidence of fatigue developments.

3.2.1.1 *Discussion*—The average life maybe as much as five times the rating life.

¹ This specification is under the jurisdiction of ASTM Committee F34 on Rolling Element Bearings and is the direct responsibility of Subcommittee F34.04 on Automotive/Industrial Bearing.

Current edition approved May 1, 2016. Published May 2016. Originally approved in 2001. Last previous edition approved in 2008 as F2162 – 01(2008). DOI: 10.1520/F2162-01R16.

² For referenced ASTM standards, visit the ASTM website, www.astm.org, or contact ASTM Customer Service at service@astm.org. For *Annual Book of ASTM Standards* volume information, refer to the standard's Document Summary page on the ASTM website.

³ Available from Global Engineering Documents, 15 Inverness Way, East Englewood, CO 80112-5704, <http://www.global.ihs.com>.

⁴ Available from Society of Automotive Engineers (SAE), 400 Commonwealth Dr., Warrendale, PA 15096-0001, <http://www.sae.org>.

⁵ Available from USA Information Systems, 1092 Laskin Rd., Ste. 208, Virginia Beach, VA 23451.

⁶ Available from the American Bearing Manufacturer's Association, 1200 19th St. NW, Ste. 300, Washington, DC 20036-2401.

⁷ Available from American National Standards Institute (ANSI), 25 W. 43rd St., 4th Floor, New York, NY 10036, <http://www.ansi.org>.

3.2.2 *basic dynamic load rating* (C_r), n —for a radial roller bearing, that calculated, constant radial load that a group of apparently identical bearings with stationary outer rings can theoretically endure for a rating life of one million revolutions of the inner ring.

3.2.2.1 *Discussion*—Since applied loading as great as the basic dynamic load rating tends to cause local plastic deformation of the rolling surfaces, it is not anticipated that such heavy loading would normally be applied.

3.2.3 *basic static load rating* (C_{or}), n —for a radial roller bearing, that uniformly distributed static radial load which produces a maximum contact stress of 580 000 psi (4000 Mpa) at the center of the contact of the most heavily loaded rolling element.

3.2.3.1 *Discussion*—For this contact stress, total permanent deformation of rolling element and raceway occurs which is approximately 0.0001 or the roller diameter.

3.2.4 *rating life* (L_{10}), n —for a radial roller bearing, the number of revolutions that 90 % of a group of bearings will complete or exceed before the first evidence of fatigue develops.

4. Classification

4.1 This specification covers the following types of roller bearings:

- 4.1.1 *Type B*—Open end roller bearings, and
- 4.1.2 *Type M*—Closed end roller bearings.

5. Ordering Information

5.1 When ordering parts in accordance with this specification, specify the following:

- 5.1.1 ASTM designation number, including year of issue,
- 5.1.2 Type, whether Type B or Type M roller bearings (see Section 4) are to be furnished,
- 5.1.3 Dash number (see Table 1),

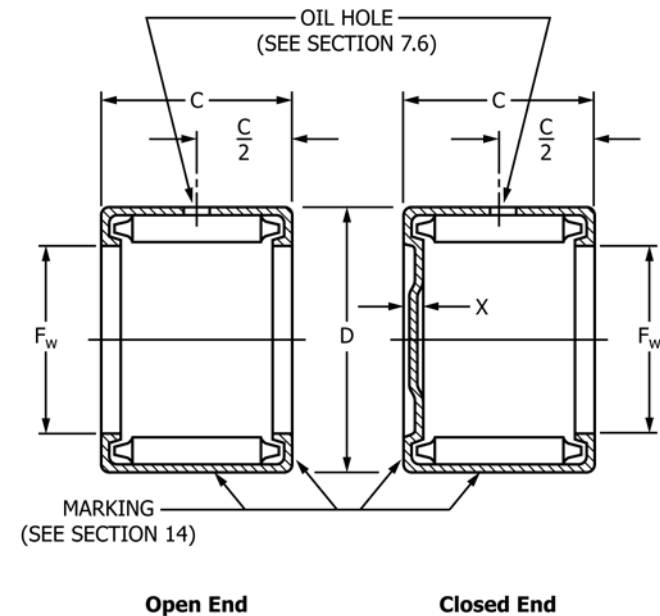

FIG. 1 Schematic Drawing of Type B and Type M Roller Bearings

5.1.4 Dimensions of roller bearings, including:

- 5.1.4.1 Bore diameter, in;
- 5.1.4.2 Ring gage diameter, in;
- 5.1.4.3 Width, in; and
- 5.1.4.4 Shaft diameter, in;
- 5.1.5 Load rating, including basic static load rating, lb and basic dynamic load rating, lb;
- 5.1.6 Approximate limiting speed, rpm; and
- 5.1.7 Maximum end thickness.

6. Materials and Manufacture

6.1 *Needle Rollers*—Needle rollers shall be manufactured of steel, alloy or carbon, of grades E50100 or E52100 in accordance with SAE AHS STD-66, or 1090 or 1095 in accordance with SAE J-404.

6.2 *Rings*—Rings shall be manufactured of steel, alloy, or carbon, carburizing grade 4620, 4720, 8620, 8720, or 1010-1020 in accordance with SAE AHS STD-66.

7. Other Requirements

7.1 *Heat Treatment:*

7.1.1 *Needle Rollers*—Needle rollers shall be through-hardened to Rockwell HRC58 or equivalent, in accordance with Test Methods E18.

7.1.2 *Rings*—Rings shall be case hardened to surface hardness of Rockwell HRC58-65 or equivalent, in accordance with Test Methods E18 with a 0.003 in. minimum case depth.

7.1.2.1 This case depth will not support Rockwell HR15N. Use of a standard file test in accordance with SAE J-864 or microsection and microhardness test in accordance with Test Method E18 is required to determine the surface hardness.

7.1.3 *Shafts*—Bearings are intended to be used with shafts hardened to Rockwell HRC58-65 in accordance with Test Methods E18.

7.1.3.1 When an open end bearing is used with an unhardened shaft, the bearing shall be used in conjunction with an inner bearing ring (Specification F2163).

7.2 *Protective Coating:*

7.2.1 Needle rollers and rings shall be furnished without plating.

7.2.2 Manufacturer shall coat bearings with rust preventive film.

7.3 *Lubrication*—Bearings shall be furnished without lubrication.

7.4 Rollers shall be retained by the outer ring.

7.5 Bearings shall not be furnished with roller separators.

7.6 Oil holes shall be furnished in accordance with the manufacturer's standard practice.

8. Dimensions, Mass, and Permissible Variations

8.1 Products manufactured in accordance with this specification shall meet the requirements shown in Table 1.

8.2 *Plug Gages*—The “go” plug gage is the same size as the minimum diameter under the needle rollers column in Table 1, and the “no go” plug gage size is 0.0001 in. larger than the maximum diameter under the needle rollers column in Table 1.