



Designation: C119 – 16

## Standard Terminology Relating to Dimension Stone<sup>1</sup>

This standard is issued under the fixed designation C119; the number immediately following the designation indicates the year of original adoption or, in the case of revision, the year of last revision. A number in parentheses indicates the year of last reapproval. A superscript epsilon ( $\epsilon$ ) indicates an editorial change since the last revision or reapproval.

*This standard has been approved for use by agencies of the U.S. Department of Defense.*

### INTRODUCTION

*Dimension stone*, as used here, is natural stone that has been selected and fabricated to specific sizes or shapes, with or without one or more mechanically dressed or finished surfaces, for use as building facing, curbing, paving stone, monuments and memorials, and various industrial products. The term *dimension stone* is in contradistinction to crushed and broken stone, such as is used for aggregate, roadstone, fill, or chemical raw materials. Because all stone is a natural material, the definition excludes all manmade materials that simulate stone. In common practice, some dimension stones are reinforced, filled, or surface treated.

Terms used in definitions and nomenclature shall be interpreted in accordance with commonly accepted scientific and technical terms of the geological sciences except as otherwise specifically noted.

Examples of such exceptions are the broader commercial definitions of granite and marble, which have become well established in the dimension stone industry and trade. Definitions and terms included in these definitions have been formulated in accordance with common industrial usage *where this is not in conflict with current scientific usage*.

### GENERAL TERMS

**anchor**—in general, a metal shape inserted into a slot or hole in the stone that provides for the transfer of loads from the stone to the building structure, either directly or through an intermediate structure.

**anchorage**—the system consisting of stone, anchor and primary structure, secondary structure or back-up preventing lateral movement of the stone.

**arris**—the junction of two planes of the same stone forming an external edge.

**ashlar**—(1) a squared block of building stone; (2) a masonry of such stones; (3) a thin-dressed rectangle of stone for facing of walls (often called ashlar veneer).

**bearing check**—a slot, generally not continuous, cut into the back or bed of dimension stone to accommodate a supporting angle or clip (see Fig. 1.)

**building stone**—natural rock of adequate quality to be quarried and cut as dimension stone as it exists in nature, as used in the construction industry.

**chip**—an irregularly shaped fragment dislodged from a stone surface.

**cladding**—nonload-bearing stone used as the facing material in wall construction that contains other materials.

**coping**—dimension stone used as the top course of a masonry wall, often sloped to shed water.

**crack**—a partial break in the stone (see fracture, microcrack, seam).

**cubic stock**—in general, a thick dimension stone unit which is not precisely defined in terms of thickness for every kind of stone, particularly for limestone and sandstone. For marble or granite, cubic stock is a unit that is greater than 50 mm in thickness. For limestone, cubic stock is a unit that is greater than 75 mm to 100 mm in thickness, and for sandstone, a unit that is greater than 150 mm to 200 mm in thickness. (In contrast, see *thin stone*.)

**cut stone**—stone fabricated to specific dimensions.

<sup>1</sup> This terminology is under the jurisdiction of ASTM Committee C18 on Dimension Stone and is the direct responsibility of Subcommittee C18.91 on Nomenclature and Definitions.

Current edition approved May 1, 2016. Published May 2016. Originally approved in 1926. Last previous edition approved in 2014 as C119 – 14<sup>ε1</sup>. DOI: 10.1520/C0119-16.

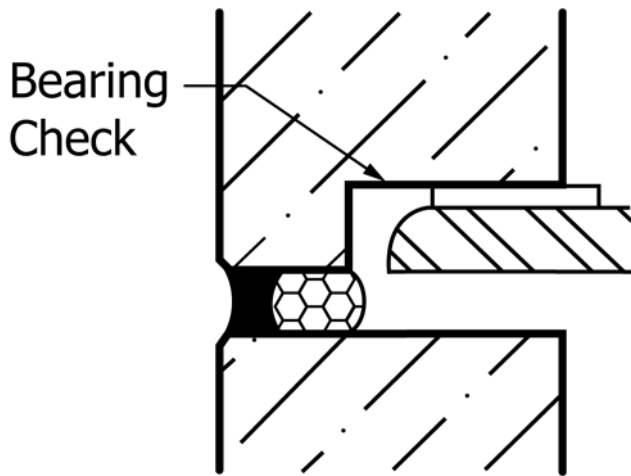

FIG. 1 Bearing Check

**fracture**—a complete break in the stone (see crack, microcrack, seam).

**freestone**—a stone having little or no preferential direction of splitting which may be cut freely in any direction without fracture or splitting.

**grain**—(1) a distinguishable rock constituent which itself has a distinct identity, for example, a mineral crystal, an oolith, a rock fragment (in sedimentary rocks), or clast.

(2) a direction in a rock body along which it is more easily broken, split, or cut. See rift.

**granular**—composed of particles visible to the unaided eye. For sedimentary stone, the predominant particle distribution is less than 4 mm in size.

**hysteresis**—the residual strain in stone after the stress causing such strain is changed.

**installation**—the process of assembling dimension stone into a structure.

**kerf**—(1) a slot, either local or continuous, cut into the edge of a stone, typically with a saw blade, for insertion of anchors. (2) the width of a cut when sawing through stone blocks or jointing slabs. (See Fig. 2.)

**lamination**—when applied to the processing of dimension stone, refers to the adhesive bonding of multiple layers of stone, or stone to other materials.

**liner**—a small block of stone secured to the rear face of a dimension stone panel with pins and adhesive for the purpose of providing a concealed horizontal bearing surface (see Fig. 3a and 3b in C1242).

**microcrack**—a crack too small to be seen with the unaided eye (see crack, fracture, seam).

**microfissure**—a fissure that cannot be seen with the unaided eye.

**monumental stone**—rock of adequate quality to be quarried and cut as dimension stone as it exists in nature, as used in the monument and memorial industry.

**dimension stone**—natural stone that has been selected and fabricated to specific sizes or shapes.

*DISCUSSION*—The term *dimension stone* is in contradistinction to crushed and broken stone, such as is used for aggregate, roadstone, fill, or chemical raw materials. In common practice, some dimension stones are reinforced, filled, or surface treated.

*dressed stone*—See **cut stone**, **finished stone**.

**durability**—the measure of the ability of dimension stone to endure and to maintain its essential and distinctive characteristics of strength, resistance to decay, and appearance. Durability is based on the length of time that a stone can maintain its innate characteristics in use. This time will vary depending on the environment, the use, and the finish of the stone in question (for example, outdoor versus indoor use).

**dry seam**—a natural separation that has not been filled or bonded.

**fabrication**—when applied to dimension stone, any of the processes involved in changing a raw stone piece to its final end use form. This includes, but is not limited to cutting, splitting, grinding, drilling, or face-finishing.

**fading (slate)**—a slate that has a significant color change within the first year of exposure to weather, often the result of chemical alteration of the iron minerals.

**finished stone**—dimension stone with one or more mechanically exposed surfaces.

**filling**—the application of materials, often cements or synthetic resins, into natural voids in a stone during fabrication.

**fissure**—a naturally occurring separation which may or may not affect the performance of the stone.

**flagstone**—nominally flat pieces of stone generally furnished in irregular shapes with broken edges, typically used for paving.

**fleuri-cut (cross-cut)**, *adj*—describes stone that is cut parallel to the natural veining.

**flooring**—stone used as in interior pedestrian wearing surface.

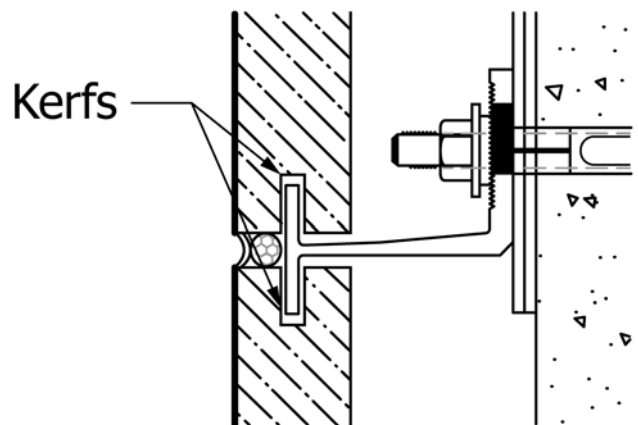

FIG. 2 Kerfs

**open seams**—unfilled fissures or naturally occurring cracks in stone.

**panel**—cut stone with face dimensions large in relation to its thickness, for placement in a building structure or frame assembly.

**paving**—stone used in an interior pedestrian wearing surface as in patios, walkways, driveways, and the like. (See *flooring*)

**pits**—small depressions, voids or pinholes in stone, especially on a finished surface.

**polished finish**—a surface that has high luster and strong reflection of incident light.

**processing**—the work involved in transforming quarry blocks into dimension stone, including sawing, drilling, grinding, honing, polishing, carving, and all other operations necessary for installation.

**rebated kerf**—A kerf that includes a second cut at 90 degrees to the kerf axis to accommodate the anchor configuration and prevent the anchor from interfering with movement capability at the stone joint (see Fig. 3).

**resination**—a cosmetic enhancement to stone slabs containing pits, fissures, cracks or other surface irregularities in which an adhesive resin of epoxy, polyester, or acrylic base has been applied to the slab face and allowed to cure prior to the polishing of the slab.

**ribbon**—in some slate, narrow bands of contrasting color or appearance differing in some degree in chemical composition from the main body.

**rift**—(1) a consistent direction or trend in a rock body along which the rock is most easily split or broken.

(2) The grain orientation in stone, particularly in sedimentary stones, showing more or less clearly how the stone was originally bedded, and with or without color or grain-size changes or voids.

**rock**—a naturally occurring, consolidated aggregation of one or more minerals constituting the crust of the Earth.

**rustication (or reveal)**—a continuous groove cut within the face or along the edge of a dimension stone panel, usually for the purpose of visually imitating or accentuating a joint location (see Fig. 4).

**sample**—a small part or quantity of stone, usually a slab, panel, or ashlar, that is cut from a larger block of stone.

**seam**—a naturally filled or bonded feature in the stone, such as a streak or a vein, which may or may not adversely affect the strength of a stone (see **crack**, **fracture**, **microcrack**).

**shaped stone**—dimension stone processed by carving, grinding, sawing, or other means into specific nonplanar configurations.

**shop drawings**—when applied to dimension stone, a highly detailed drawing that shows the net dimensions, joint dimensions, anchor locations and orientations, of the dimension stone and the relationship with the other building materials being used.

**slab**—a piece of stone produced by shaving or splitting in the first milling or quarrying operation. A slab has two parallel surfaces.

**snip**—the area of a stone surface from which a chip has been dislodged.

**sound stone**—stone which is free of cracks, fissures, or other physical defects.

**spalls**—(1) fragments or chips from a piece of dimension stone. (2) waste stone usually of small size from the quarrying and milling of dimension limestone.

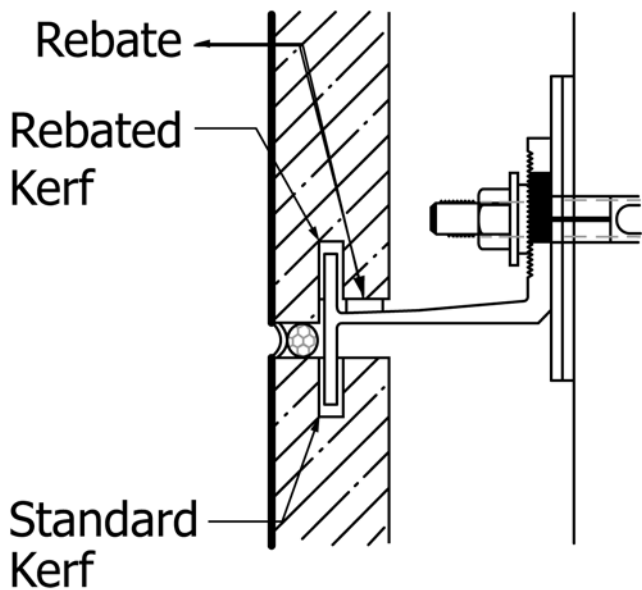

FIG. 3 Rebated Kerf

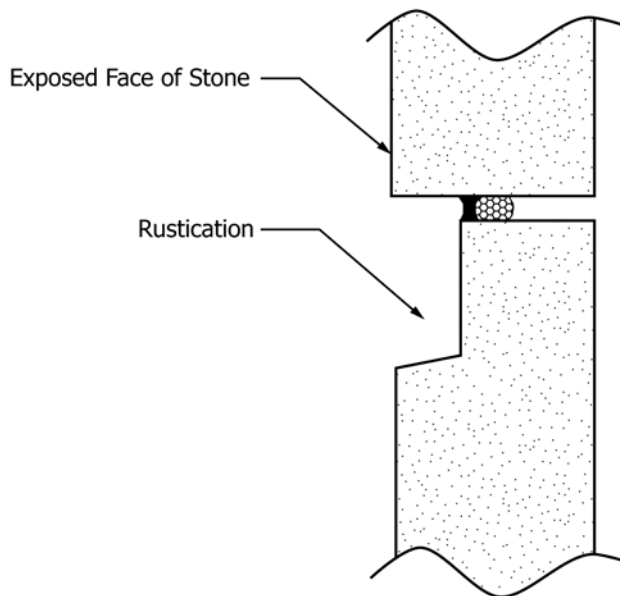

FIG. 4 Rustication

**specifying authority**—party requiring testing of dimension stone material.

**specimen**—an individual piece of stone that is cut from a sample to be used for physical or mechanical testing.

**sticking**—a method of repairing the butt edge of a broken piece of stone, generally done with dowels, cements, or epoxies. The pieces are “stuck” together, thus “sticking”.

**stone**—a naturally-consolidated substance formed from minerals, geologically synonymous with rock (see *rock*, see *dimension stone* if selected or fabricated).

DISCUSSION—This term does not include any manufactured stone-like products or manmade materials that simulate stone.

**texture**—

(1) a modified appearance of dimension stone resulting from one or several mechanical surface treatments. Untreated stone surfaces have textural characteristics described under (2).

(2) that aspect of the physical appearance of a rock that is determined by size, shape, and mutual relations of the component grains or crystals. Textures related to dimension stone include *equigranular* (grains of approximately the same size); *inequigranular* (grains of markedly unequal sizes); *porphyritic* (see Note 2 under Granite Group); *interlocking* (in which grains with irregular boundaries interlock by mutual penetration); interlocking and porphyritic textures are characteristic of granites and marbles; *clastic* (naturally cemented fragmental grains but without mosaic or interlocking relations; this texture is typical of sandstones and some limestones); *mosaic* (closely packed grains with smooth to moderately irregular, noninterlocking mutual boundaries); *granoblastic* (a megascopically granular mosaic texture in which the grains are tightly compacted and the minerals are dominantly equidimensional and present irregular mutual boundaries; mosaic and granoblastic textures are characteristic of metamorphic rocks).

**thermal hysteresis**—the permanent, incremental deformation of certain stones due to thermal cycling, usually associated with loss of strength.

**thin stone/thin veneer**—a cladding under 50 mm (2-in.) thick.

**tile**—a thin modular stone unit.

**unfading (slate)**—a slate that shows no significant color change within the first year of exposure.

**vein-cut**, *adj*—describes stone that is cut perpendicular to the natural veining.

**veining**—the presence in an otherwise homogeneous stone of bands, streaks or irregular bodies of a contrasting color or appearance, and frequently having a different mineralogical composition to the predominant material. “Veining” does not apply to gneiss, commercial granite types, and slate (see *ribbon*).

**veneer**—a nonload-bearing facing of stone attached to a backing for the purpose of ornamentation, protection, or insulation.

DISCUSSION—Veneer shall support no vertical load other than its own weight and possibly the vertical dead load of veneer above.

*walls, veneered*—See *veneer*.

**waxing**—the practice of filling minor surface voids in stone with certain polyester compounds, cabinetmaker’s wax, or melted shellac. (It does not refer to the application of paste wax to make the surface shinier.)

**wear**—the removal of material or impairment of surface finish through friction or impact.

DISCUSSION—Wear is an artificial process. The rate of wear may be affected by chemical action.

**weathering**—natural alteration by either chemical or mechanical processes due to the action of constituents of the atmosphere, surface water or ground water, or to temperature change.

DISCUSSION—Changes by weathering are not necessarily undesirable or harmful; rather they may enhance the texture and color of the stone.

## STONE FINISHES—BY FAMILY

Every material used in construction has a finish or surface; dimension stone has a plethora of finishes. This section describes common finishes and classifies them into a number of families by relief or roughness. The finishes in each family are also arranged from the least relief to the most relief.

Stone finishes are a complex matter for a number of reasons. New manufacturing or finishing methods or variations or combinations of other methods of finishing stone are continually being developed. Stone finish names sometimes overlap or are variations of other finishes.

Finish options for any kind of stone vary by the geologic category of the stone (whether igneous, metamorphic, or sedimentary) and the unique combination of geological or physical properties of the stone type. This means that any particular finish cannot be put on every type of stone (see Applicability of Finishes for Various Stone Types Table in Guide C1528 for Selection of Dimension Stone for Exterior Use). The individual definitions are sometimes nonspecific or nearly overlap. In practice, a detailed definition of a specific stone finish is established between the producer and designer through dialogue, or reference sample(s), or both.

The family or individual title “finish” will be used uniformly throughout this section for ease of reference, although the term “surface” would be more accurate when no work has been done on it and no improvements made postquarry (as in certain rough finishes; see Note 2). “Surface” will be used uniformly in the sense of the outward appearance or face of the stone. Thus we have the Least Textured Finishes (family) and the Polished (finish)—a highly-reflective surface, and so forth.

### *Surface Variation*

The dimensions of variation in surface profile given in the following definitions are for indicative purposes only. The values do not denote acceptable tolerances or minimum or maximum values of surface variation for any given finish.

### LEAST TEXTURED FINISHES

(less than 1 mm [ $1/32$  in.] of surface variation)

**polished**—a highly-reflective surface, produced by mechanical abrasion and buffing.