



Designation: **D8002—15 D8002 – 15<sup>ε1</sup>**

## Standard Test Method for Modified Fouling Index (MFI-0.45) of Water<sup>1</sup>

This standard is issued under the fixed designation D8002; the number immediately following the designation indicates the year of original adoption or, in the case of revision, the year of last revision. A number in parentheses indicates the year of last reapproval. A superscript epsilon ( $\epsilon$ ) indicates an editorial change since the last revision or reapproval.

---

<sup>ε1</sup> NOTE—Note 12 was editorially corrected in June 2016.

---

### 1. Scope

1.1 This test method covers the determination of the modified fouling index (MFI) of water measured at constant pressure. This test can be used to indicate the fouling potential of reverse osmosis/nanofiltration (RO/NF) feed water due particulate matter and is applicable to low and high turbidity waters. Since the size, shape, and nature of particulate matter in water may vary, this test method is not an absolute measurement of the quantity of particulate matter.

1.2 This test method is not applicable for reagent-grade water Types I, II, and III of Specification **D1193** or effluents from most reverse osmosis and ultra-filtration systems.

1.3 The values stated in SI units are to be regarded as standard. No other units of measurement are included in this standard.

1.4 *This standard does not purport to address all of the safety concerns, if any, associated with its use. It is the responsibility of the user of this standard to establish appropriate safety and health practices and determine the applicability of regulatory limitations prior to use.*

### 2. Referenced Documents

2.1 *ASTM Standards:*<sup>2</sup>

**D1129** Terminology Relating to Water

**D1193** Specification for Reagent Water

**D2777** Practice for Determination of Precision and Bias of Applicable Test Methods of Committee D19 on Water

**D3370** Practices for Sampling Water from Closed Conduits

**D4189** Test Method for Silt Density Index (SDI) of Water

**D6161** Terminology Used for Microfiltration, Ultrafiltration, Nanofiltration and Reverse Osmosis Membrane Processes

**D7726** Guide for The Use of Various Turbidimeter Technologies for Measurement of Turbidity in Water

### 3. Terminology

3.1 *Definitions:*

3.1.1 For definitions of terms used in this standard, refer to Terminologies **D1129** and **D6161**.

3.2 *Definitions of Terms Specific to This Standard:*

3.2.1 *modified fouling index, MFI-0.45, n*—index calculated from the development of filtration velocity through a 0.45- $\mu\text{m}$  membrane filter. **D2777**

### 4. Summary of Test Method

4.1 Water is passed through a 0.45- $\mu\text{m}$  membrane filter at constant pressure of 200 kPa and the development of the rate of filtration is measured continuously.

4.2 The MFI is calculated from the obtained data of flow versus time at constant pressure and temperature.

### 5. Significance and Use

5.1 This test method is an alternative for the silt density index (SDI) method (Test Method **D4189**) with the aim to overcome inaccuracies related to a nonlinear relation with the fouling potential due to particulate matter concentration, absence of temperature correction, support pad, and time.

<sup>1</sup> This test method is under the jurisdiction of ASTM Committee **D19** on Water and is the direct responsibility of Subcommittee **D19.08** on Membranes and Ion Exchange Materials.

Current edition approved July 15, 2015. Published August 2015. DOI: ~~10.1520/D8002-15~~10.1520/D8002-15E01.

<sup>2</sup> For referenced ASTM standards, visit the ASTM website, [www.astm.org](http://www.astm.org), or contact ASTM Customer Service at [service@astm.org](mailto:service@astm.org). For *Annual Book of ASTM Standards* volume information, refer to the standard's Document Summary page on the ASTM website.

5.2 The MFI-0.45 can serve as a useful indication of the quantity of particulate matter.

5.3 The MFI-0.45 can be used to determine effectiveness of various processes such as filtration or clarification used to remove particulate matter.

5.4 The MFI-0.45 has empirically been correlated with fouling tendency of some water treatment equipment such as reverse osmosis (RO) devices.

## 6. Apparatus

6.1 *MFI Assembly*—As described in Fig. 1 and Fig. 2, wetted parts should be made of high-quality stainless or plastic to prevent contamination by corrosion products. Do not use reactive materials such as carbon steel, galvanized steel, cast iron, and copper alloys. Suitable filter holders, designed to withstand an operational gage pressure of 350 kPa, can be obtained from suppliers of membrane filters. The filter holder should be equipped with a device releasing air.

# iTeh Standards (<https://standards.itih.ai>) Document Preview

[ASTM D8002-15e1](https://standards.itih.ai/catalog/standards/astm/bb09c727-9286-4df8-8fc9-adab5f197114/astm-d8002-15e1)

<https://standards.itih.ai/catalog/standards/astm/bb09c727-9286-4df8-8fc9-adab5f197114/astm-d8002-15e1>

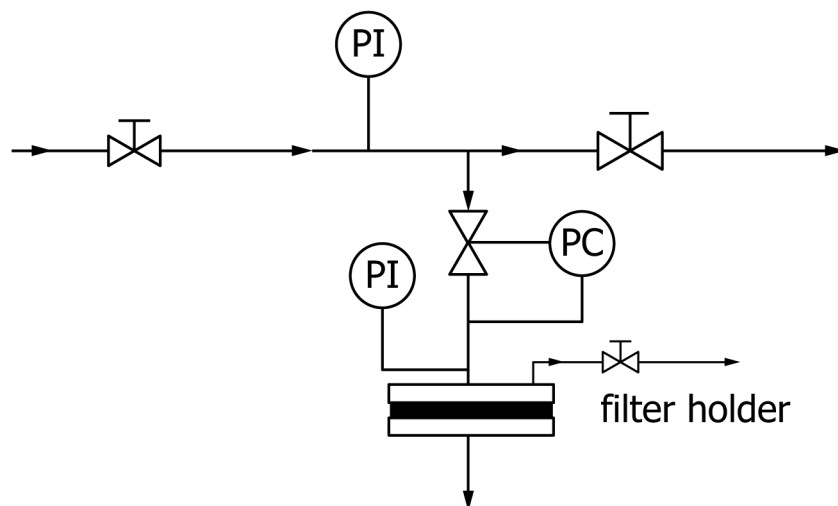

NOTE 1—PI is pressure indicator; PC is pressure controller.

**FIG. 1 Apparatus for Measuring MFI at Constant Pressure with a Pump**

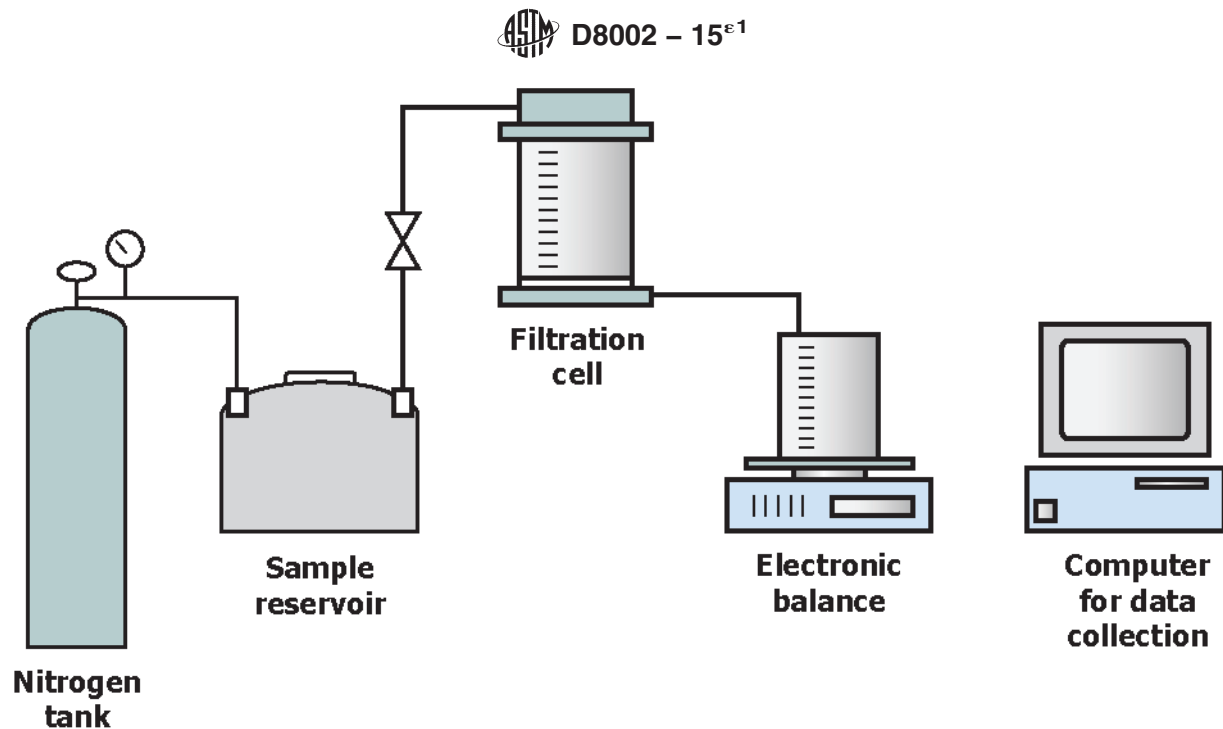

FIG. 2 Representative Apparatus for Measuring MFI at Constant Pressure with a Pressure Vessel

## 6.2 Membrane Filter:

6.2.1 Membrane, white hydrophilic, mixed cellulose nitrate (50–75 %) and mixed cellulose acetate (MCE).

6.2.2 Replaceable Highly Porous Foam Support Pad, to be placed on the bottom of the filter holder.

6.2.3 Mean Pore Size, 0.45  $\mu\text{m}$ .

6.2.4 Diameter, 47 mm.

6.2.5 Thickness, 115 to 180  $\mu\text{m}$ .

6.2.6 Pure Water Flow, 25 to 50 s/500 mL.

6.2.7 Pressure Difference across Membrane Filter, 200 kPa.

6.2.8 Bubble Point, 179 to 248 kPa.

6.2.9 Use only filters that are packaged in the same orientation. [ASTM D8002-15e1](https://standards.iteh.ai/ASTM-D8002-15e1) <https://standards.iteh.ai/ASTM-D8002-15e1>

6.3 Thermometer or Sensor Suitable for Measuring Temperature of the Water Sample, capable of being read or registered  $\pm 1^\circ\text{C}$ .

6.4 Electronic flow meter or mass balance.

6.5 Computer or data-collecting and processing device.

## 7. Procedure

7.1 Assemble apparatus as shown in Fig. 1 and Fig. 2 including flow-measuring devices (electronic flow meter or mass balance) and set the pressure regulator at 200 kPa.

7.2 Before installing the membrane filter, flush the water to be tested through the apparatus to remove contaminants. For sampling, follow the procedure given in Practices D3370. Discrete samples can be used with appropriate pressurizing apparatus such as a pump or an air/nitrogen pressurized vessel.

NOTE 1—The pump should be of such a design that grinding flocs will not occur or be minimal.

NOTE 2—Ensure that the sample to be tested is not super saturated with air or nitrogen.

7.3 Measure the temperature of the water.

7.4 Open the membrane filter holder and place a 0.45- $\mu\text{m}$  membrane filter (47 mm in diameter) on the support plate of the holder. A replaceable foam support pad needs to be placed on the support plate of the holder. Handle the membrane filter only with dull tweezers to avoid puncturing. Avoid touching the membrane filter with fingers.

NOTE 3—Record the manufacturer of the membrane filter and manufacturer's identification for the membrane filter.

7.5 Make sure the O-ring is in good condition and properly placed.

7.6 Replace the top of the half of the filter holder and close loosely.

7.7 Bleed out air by opening the pressure relieve valve and open the small air relieve valve on top of the filter holder.