



Designation: C293/C293M – 16

Standard Test Method for Flexural Strength of Concrete (Using Simple Beam With Center-Point Loading)¹

This standard is issued under the fixed designation C293/C293M; the number immediately following the designation indicates the year of original adoption or, in the case of revision, the year of last revision. A number in parentheses indicates the year of last reapproval. A superscript epsilon (ϵ) indicates an editorial change since the last revision or reapproval.

This standard has been approved for use by agencies of the U.S. Department of Defense.

1. Scope*

1.1 This test method covers determination of the flexural strength of concrete specimens by the use of a simple beam with center-point loading. Test Method C293/C293M is not an alternative to Test Method C78/C78M.

1.2 The values stated in either SI units or inch-pound units are to be regarded separately as standard. The values stated in each system may not be exact equivalents; therefore, each system shall be used independently of the other. Combining values from the two systems may result in non-conformance with the standard.

1.3 *This standard does not purport to address all of the safety concerns, if any, associated with its use. It is the responsibility of the user of this standard to establish appropriate safety and health practices and determine the applicability of regulatory limitations prior to use.*

2. Referenced Documents

2.1 *ASTM Standards:*²

C31/C31M Practice for Making and Curing Concrete Test Specimens in the Field

C78/C78M Test Method for Flexural Strength of Concrete (Using Simple Beam with Third-Point Loading)

C192/C192M Practice for Making and Curing Concrete Test Specimens in the Laboratory

C617/C617M Practice for Capping Cylindrical Concrete Specimens

C1077 Practice for Agencies Testing Concrete and Concrete Aggregates for Use in Construction and Criteria for Testing Agency Evaluation

E4 Practices for Force Verification of Testing Machines

¹ This test method is under the jurisdiction of ASTM Committee C09 on Concrete and Concrete Aggregates and is the direct responsibility of Subcommittee C09.61 on Testing for Strength.

Current edition approved April 15, 2016. Published June 2016. Originally approved in 1952. Last previous edition approved in 2015 as C293/C293M – 15. DOI: 10.1520/C0293_C0293M-16.

² For referenced ASTM standards, visit the ASTM website, www.astm.org, or contact ASTM Customer Service at service@astm.org. For *Annual Book of ASTM Standards* volume information, refer to the standard's Document Summary page on the ASTM website.

2.2 *TXDOT Standard:*³

TEX-420-A Test Method for Flexural Strength of Concrete Using Simple Beam with Center-Point Loading

3. Significance and Use

3.1 This test method is used to determine the modulus of rupture of specimens prepared and cured in accordance with Practices C31/C31M or C192/C192M. The strength determined will vary where there are differences in specimen size, preparation, moisture condition, or curing.

3.2 The results of this test method may be used to determine compliance with specifications or as a basis for proportioning, mixing and placement operations. This test method produces values of flexural strength significantly higher than Test Method C78/C78M.

4. Apparatus

4.1 *Testing Machine*—The testing machine shall conform to the requirements of the sections on Basis of Verification, Corrections, and Time Interval Between Verifications of Practices E4. Hand operated testing machines having pumps that do not provide a continuous loading to failure in one stroke are not permitted. Motorized pumps or hand operated positive displacement pumps having sufficient volume in one continuous stroke to complete a test without requiring replenishment are permitted and shall be capable of applying loads at a uniform rate without shock or interruption. The testing machine shall be equipped with a means of recording or holding the peak value that will indicate the maximum load applied to the specimen during a test, to within 1 % accuracy of the load being applied.

4.2 *Loading Apparatus*—The mechanism by which forces are applied to the specimen shall employ a load-applying block and two specimen support blocks. It shall ensure that all forces are applied perpendicular to the face of the specimen without eccentricity. A diagram of an apparatus that accomplishes this purpose is shown in Fig. 1.

³ *Manual of Testing Procedures*, Texas State Department of Highways and Public Transportation, 1986.

*A Summary of Changes section appears at the end of this standard

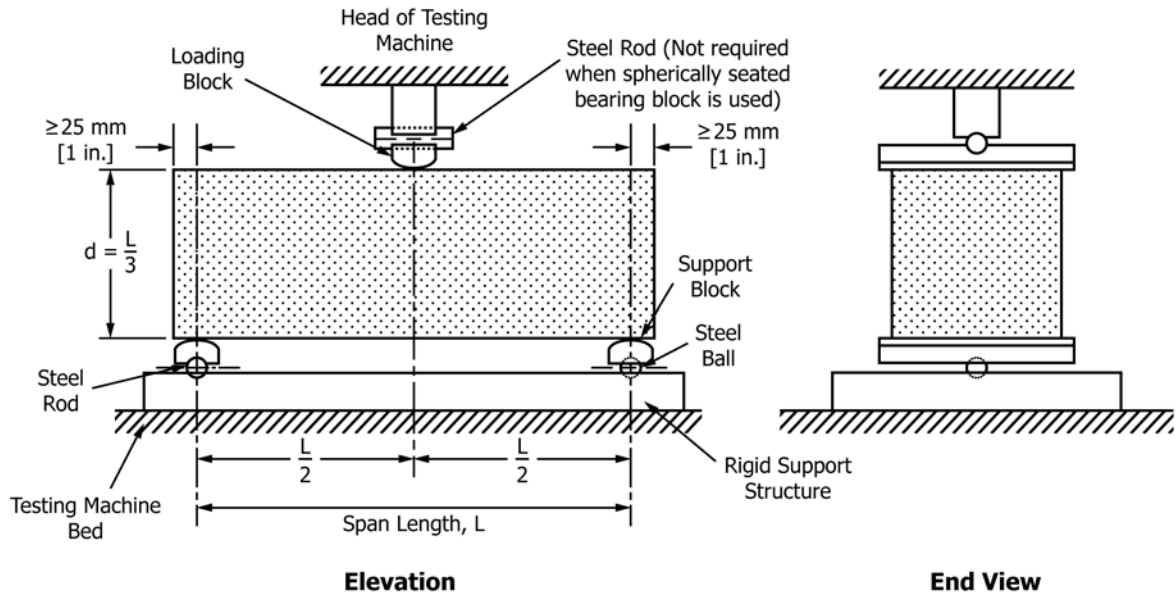

NOTE 1—Apparatus may be used inverted.
FIG. 1 Schematic of a Suitable Apparatus for Flexure Test of Concrete by Center-Point Loading Method.

4.2.1 All apparatus for making center-point loading flexure tests shall be similar to Fig. 1 and maintain the span length and central position of the load-applying block with respect to the support blocks constant within ± 1.0 mm [± 0.05 in.].

4.2.2 Reactions shall be parallel to the direction of the applied load at all times during the test, and the ratio of the horizontal distance between the point of load application and nearest reaction to the depth of the beam shall be $1.5 \pm 2\%$.

4.2.3 The load-applying and support blocks shall not be more than 65 mm [2.50 in.] high, measured from the center or the axis of pivot, and shall extend at least across the full width of the specimen. Each hardened bearing surface in contact with the specimen shall not depart from a plane by more than 0.05 mm [0.002 in.] and shall be a portion of a cylinder, the axis of which is coincidental with either the axis of the rod or center of the ball, whichever the block is pivoted upon. The angle subtended by the curved surface of each block shall be at least 0.80 rad [45°]. The load-applying and support blocks shall be maintained in a vertical position and in contact with the rod or ball by means of spring-loaded screws that hold them in contact with the pivot rod or ball. The rod in the center load-applying block in Fig. 1 may be omitted when a spherically seated bearing block is used.

5. Testing

5.1 The test specimen shall conform to all requirements of Practice C31/C31M or C192/C192M applicable to beam specimens and shall have a test span within 2 % of being three times its depth as tested. The sides of the specimen shall be at right angles with the top and bottom. All surfaces shall be smooth and free of scars, indentations, holes, or inscribed identification marks.

5.2 The individual who tests concrete beams for acceptance testing shall meet the concrete laboratory requirements of Practice C1077 including Test Method C293/C293M as a relevant test.

NOTE 1—The testing laboratory performing this test method may be evaluated in accordance with Practice C1077.

6. Procedure

6.1 Flexural tests of moist-cured specimens shall be made as soon as practical after removal from moist storage. Surface drying of the specimen results in a reduction in the measured modulus of rupture.

6.2 Turn the test specimen on its side with respect to its position as molded and center it on the support blocks. Center the loading system in relation to the applied force. Bring the load-applying block in contact with the surface of the specimen at the center and apply a load of between 3 and 6 % of the estimated ultimate load. Using 0.10 mm [0.004 in.] and 0.40 mm [0.015 in.] leaf-type feeler gages, determine whether any gap between the specimen and the load-applying or support blocks is greater or less than each of the gages over a length of 25 mm [1 in.] or more. Grind, cap, or use leather shims on the specimen contact surface to eliminate any gap in excess of 0.10 mm [0.004 in.]. Leather shims shall be of uniform 6 mm [0.25 in.] thickness, 25 to 50 mm [1.0 to 2.0 in.] in width, and shall extend across the full width of the specimen. Gaps in excess of 0.40 mm [0.015 in.] shall be eliminated only by capping or grinding. Grinding of lateral surfaces shall be minimized inasmuch as grinding may change the physical characteristics of the specimens. Capping shall be in accordance with applicable sections of Practice C617/C617M.

6.3 Load the specimen continuously and without shock. The load shall be applied at a constant rate to the breaking point. Apply the load so that the maximum stress on the tension face increases at a rate between 0.9 and 1.2 MPa/min [125 and 175 psi/min]. The loading rate is computed using the following equation:

$$r = \frac{2Sbd^2}{3L} \tag{1}$$