



Designation: **D6888 – 09 D6888 – 16**

Standard Test Method for Available Cyanides with Ligand Displacement and Flow Injection Analysis (FIA) Utilizing Gas Diffusion Separation and Amperometric Detection¹

This standard is issued under the fixed designation D6888; the number immediately following the designation indicates the year of original adoption or, in the case of revision, the year of last revision. A number in parentheses indicates the year of last reappraisal. A superscript epsilon (ϵ) indicates an editorial change since the last revision or reappraisal.

1. Scope

1.1 This method is used to determine the concentration of available inorganic cyanide in an aqueous wastewater or effluent. The method detects the cyanides that are free (HCN and CN⁻) and metal-cyanide complexes that are easily dissociated into free cyanide ions. The method does not detect the less toxic strong metal-cyanide complexes, cyanides that are not “amenable to chlorination.”

1.2 Total cyanide can be determined for samples that have been distilled as described in Test Methods D2036, Test Method A, Total Cyanides after Distillation. The cyanide complexes are dissociated and absorbed into the sodium hydroxide capture solution, which can be analyzed with this test method; therefore, ligand exchange reagents from Sections 8.12 and 8.13 would not be required when determining total cyanide after distillation.

1.3 This procedure is applicable over a range of approximately 2 to 400 µg/L (parts per billion) available cyanides. Higher concentrations can be analyzed by dilution or lower injection volume.

1.4 The values stated in SI units are to be regarded as standard. No other units of measurement are included in this standard.

1.5 *This standard does not purport to address all of the safety concerns, if any, associated with its use. It is the responsibility of the user of this standard to establish appropriate safety and health practices and determine the applicability of regulatory limitations prior to use.* Specific hazard statements are given in Note 28.6 and Section 9.

2. Referenced Documents

2.1 *ASTM Standards:*²

D1129 Terminology Relating to Water

D1193 Specification for Reagent Water

D2036 Test Methods for Cyanides in Water

D2777 Practice for Determination of Precision and Bias of Applicable Test Methods of Committee D19 on Water

D3856 Guide for Management Systems in Laboratories Engaged in Analysis of Water

D4375 Practice for Basic Statistics in Committee D19 on Water

D5847 Practice for Writing Quality Control Specifications for Standard Test Methods for Water Analysis

D6696 Guide for Understanding Cyanide Species

D7365 Practice for Sampling, Preservation and Mitigating Interferences in Water Samples for Analysis of Cyanide

E60 Practice for Analysis of Metals, Ores, and Related Materials by Spectrophotometry

E275 Practice for Describing and Measuring Performance of Ultraviolet and Visible Spectrophotometers

3. Terminology

3.1 *Definitions:*

3.1.1 For definitions of terms used in this standard, refer to Terminology D1129 and Guide D6696.

3.2 *Definitions of Terms Specific to This Standard:*

3.1.1 For definitions of terms used in this test method, refer to Terminology D1129 and Guide D6696.

¹ This test method is under the jurisdiction of ASTM Committee D19 on Water and is the direct responsibility of Subcommittee D19.06 on Methods for Analysis for Organic Substances in Water.

Current edition approved Oct. 1, 2009; Feb. 1, 2016. Published October 2009; June 2016. Originally approved in 2003. Last previous addition approved in 2004 as D6888 – 04; D6888 – 09. DOI: 10.1520/D6888-09; 10.1520/D6888-16.

² For referenced ASTM standards, visit the ASTM website, www.astm.org, or contact ASTM Customer Service at service@astm.org. For Annual Book of ASTM Standards volume information, refer to the standard's Document Summary page on the ASTM website.

3.2.1 *available cyanide; cyanides, n*—Inorganic cyanides that are free (HCN and CN⁻) and metal-cyanide complexes that are easily dissociated into free cyanide ions. ~~Available cyanide does not include the less toxic strong metal-cyanide complexes; cyanides that are not “amenable to chlorination.”~~

3.2.1.1 *Discussion*—

Available cyanide does not include the less toxic strong metal-cyanide complexes, cyanides that are not “amenable to chlorination” and includes weak acid dissociable or weak and dissociable (WAD) cyanides for use in the implementation of International Cyanide Management Code.

4. Summary of Test Method

4.1 Complex cyanides bound with nickel or mercury are released by ligand displacement by the addition of a ligand displacement agent ~~prior to analysis agent, when necessary.~~

4.2 Other weak and dissociable cyanide species do not require ligand displacement.

4.3 The ~~treated~~ sample is introduced into a flow injection analysis (FIA) system where it is acidified to form hydrogen cyanide (HCN). The hydrogen cyanide gas diffuses through a hydrophobic gas diffusion membrane, from the acidic donor stream into an alkaline acceptor stream.

4.4 The captured cyanide is sent to an amperometric flowcell detector with a silver-working electrode. In the presence of cyanide, silver in the working electrode is oxidized at the applied potential. The anodic current measured is proportional to the concentration of cyanide in the standard or sample injected.

4.5 Calibrations and data are processed with the instrument’s data acquisition software.

5. Significance and Use

5.1 Cyanide and hydrogen cyanide are highly toxic. Regulations have been established to require the monitoring of cyanide in industrial and domestic wastes and surface waters.³

5.2 This test method is applicable for natural water, saline waters, metallurgical process solutions, and wastewater effluent.

5.3 The method may be used for process control in wastewater treatment facilities.

6. Interferences

6.1 High levels of carbonate can release CO₂ into the acceptor stream and cause an interference with the amperometric detector that result in a slight masking effect (15 % negative bias with 20 ppb cyanide in 1500 ppm carbonate). Refer to 11.2 for sample pretreatment.

6.2 Sulfide above 50 mg/L will diffuse through the gas diffusion membrane and can be detected in the amperometric flowcell. Oxidized products of sulfide can also rapidly convert CN⁻ to SCN⁻ at a high pH. Refer to Practice D7365 for sulfide removal procedures.

6.3 Refer to Practice D7365 for further information on mitigating interferences in water samples for the analysis of cyanide.

7. Apparatus

7.1 The instrument should be equipped with a precise sample introduction system, a gas diffusion manifold with hydrophobic membrane, and an amperometric detection system to include a silver working electrode, a Ag/AgCl reference electrode, and a Pt or stainless steel counter electrode. Examples of the apparatus schematics are shown in Figs. 1 and 1-23. Example instrument settings are shown in Table 1.⁴

NOTE 1—The instrument settings in Table 1 are only examples. The analyst may modify the settings as long as performance of the method has not been degraded. Contact the instrument manufacturer for recommended instrument parameters.

7.2 An autosampler is recommended but not required to automate sample injections and increase throughput. Autosamplers are usually available as an option from the instrument’s manufacturer.

7.3 *Data Acquisition System*—Use the computer hardware and software recommended by the instrument manufacturer to control the apparatus and to collect data from the detector.

7.4 *Pump Tubing*—Use tubing recommended by instrument manufacturer. Replace pump tubing when worn, or when precision is no longer acceptable.

³ 40 CFR Part 136.

⁴ OI Analytical CNSolution 3100, FS3100, or Flow Solution IV and Lachat Instruments QuikChem Automated Ion Analyzer using Method 10-204-00-5-A have been found to be suitable for this analysis. If you are aware of alternative suppliers, please provide this information to ASTM International Headquarters. Your comments will receive careful consideration at a meeting of the responsible technical committee,¹ which you may attend.

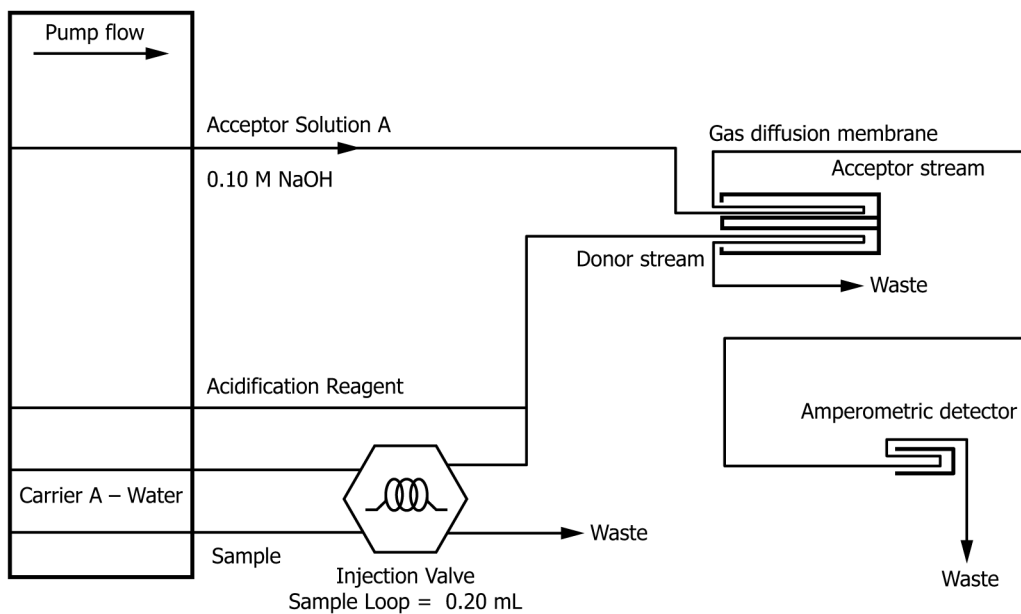

FIG. 1 Flow Injection Analysis Apparatus 1

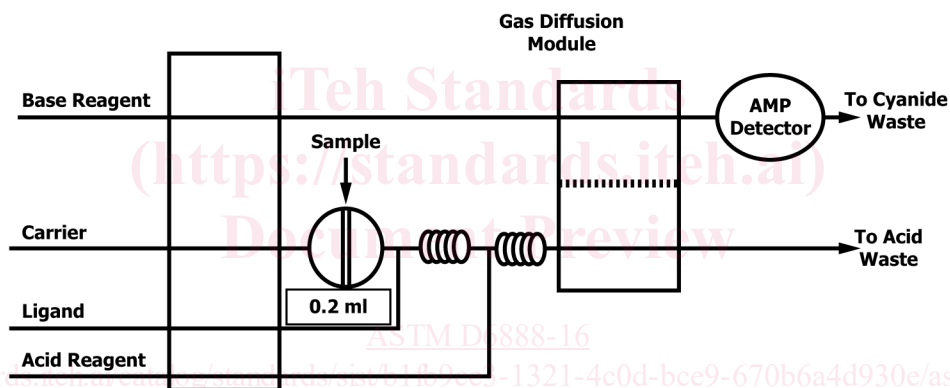

FIG. 2 Flow Injection Apparatus 2 with Automated Ligand Injection

7.5 *Gas Diffusion Membranes*—A hydrophobic membrane which allows gaseous hydrogen cyanide to diffuse from the donor to the acceptor stream at a sufficient rate to allow detection. The gas diffusion membrane should be replaced when the baseline becomes noisy or every 1 to 2 weeks.⁵

7.6 Use parts and accessories as directed by instrument manufacturer.

8. Reagents and Materials

8.1 *Purity of Reagents*—Reagent grade chemicals shall be used in all tests. Unless otherwise indicated, it is intended that all reagents shall conform to the specifications of the American Chemical Society, where such specifications are available.⁶ Other grades may be used, provided it is first ascertained that the reagent is of sufficiently high purity to permit its use without lessening the accuracy of the determination.

8.2 *Purity of Water*—Unless otherwise indicated, references to water shall be understood to mean reagent water conforming to Type II grade of Specification **D1193**.

8.3 *Sodium Hydroxide Solution (1.00 M)*—Dissolve 40 g NaOH in laboratory water and dilute to 1 L.

8.4 *Acceptor Solution A (0.10 M NaOH)*—Dissolve 4.0 g NaOH in laboratory water and dilute to 1 L.

⁵ PALL Life Sciences Part Number M5PU025, OI Analytical Analytical Part Number A001520, and Lachat Instruments Part Number 50398 have found to be suitable for this analysis.

⁶ *Reagent Chemicals, American Chemical Society Specifications*, Am. Chemical Soc., Washington, DC. For suggestions on the testing of reagents not listed by the American chemical Society, see *Analar Standards for Laboratory Chemicals*, BDH Ltd., Poole, Dorset, U.K., and the *United States Pharmacopeia*.

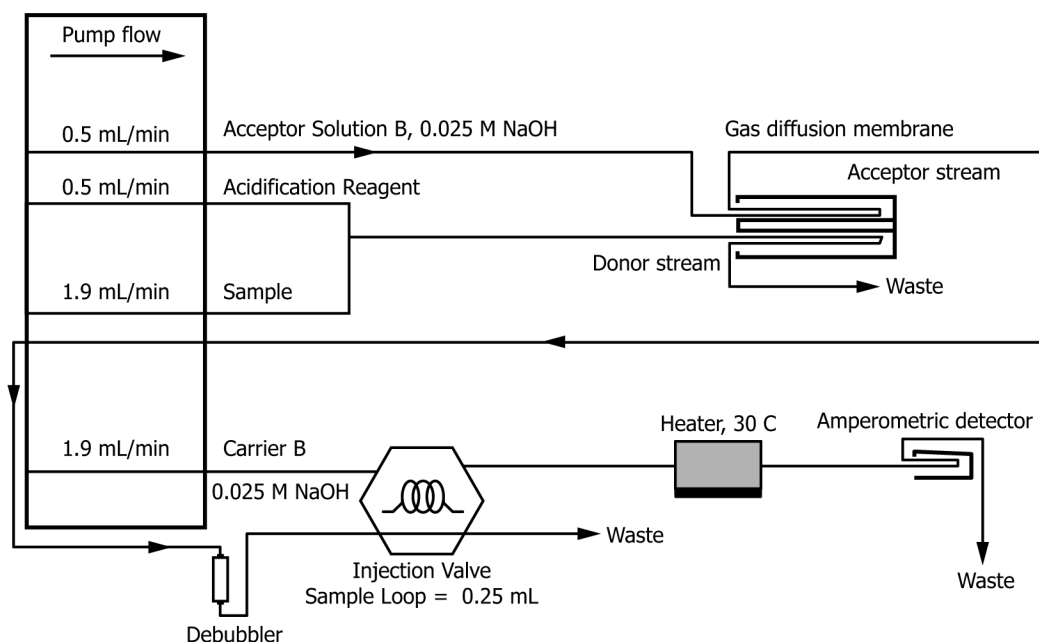

FIG. 23 Flow Injection Analysis Apparatus 23

TABLE 1 Flow Injection Analysis Parameters

FIA Instrument Parameter	Recommended Method Setting
Pump Flow Rates	0.5 to 2 mL/min
Cycle period (total)	90 to 250 s/sample
Sample load period	At least enough time to completely fill the sample loop
Reagent water rinse time between samples	At least 15 seconds
Peak Evaluation	Peak height or area
Working Potential	0.0 V vs Ag/AgCl

ASTM D6888-16

<https://standards.iteh.ai/catalog/standards/sist/b1fb9ce3-1321-4c0d-bce9-670b6a4d930e/astm-d6888-16>

8.5 *Acceptor Solution B, Carrier B* (0.025 M NaOH)—Dissolve 1.0 g NaOH in laboratory water and dilute to 1 L.

8.6 *Stock Cyanide Solution* (1000 µg/mL CN⁻)—Dissolve 2.51 g of KCN and 2.0 g of NaOH in 1 L of water. Standardize with silver nitrate solution as described in Test Methods D2036, section 16.2. Store the solution under refrigeration and check concentration approximately every 6 months and correct if necessary. **(Warning—Because KCN is highly toxic, avoid contact or inhalation.)**

NOTE 2—**Warning:** Because KCN is highly toxic, avoid contact or inhalation.

8.7 *Intermediate Cyanide Standards:*

8.7.1 *Intermediate Cyanide Standard 1* (100 µg/mL CN⁻)—Pipette 10.0 mL of stock cyanide solution (see 8.6) into a 100-mL volumetric flask containing 1 mL of 1.0 M NaOH (see 8.3). Dilute to volume with laboratory water. Store under refrigeration. The standard should be stable for 6 months.

8.7.2 *Intermediate Cyanide Standard 2* (10 µg/mL CN⁻)—Pipette 10.0 mL of Intermediate Cyanide Standard 1 (see 8.7.1) into a 100-mL volumetric flask containing 1.0 mL of 1.00 M NaOH (see 8.3). Dilute to volume with laboratory water. Store under refrigeration. The standard should be stable for 6 months.

8.8 *Working Cyanide Calibration Standards*—Prepare fresh weekly as described in 8.8.1 and 8.8.2 ranging in concentration from 2 to 400 µg/L CN⁻.

8.8.1 *Calibration Standards* (20, 50, 100, 200, and 400 µg/L CN⁻)—Pipette 20, 50, 100, 200, and 400 µL of Intermediate Cyanide Standard 1 (see 8.7.1) into separate 100-mL volumetric flasks containing 1.0 mL of 1.00 M NaOH (see 8.3). Dilute to volume with laboratory water.

8.8.2 *Calibration Standards* (2 and 10 µg/L CN⁻)—Pipette 20 and 100 µL of Intermediate Cyanide Standard 2 (see 8.7.2) into separate 100-mL volumetric flasks containing 1.0 mL of 1.00 M NaOH (see 8.3). Dilute to volume with laboratory water.

⁷ Commercial Solutions of Stock Cyanide may be substituted.