



Designation: **C770 – 98 (Reapproved 2013) C770 – 16**

Standard Test Method for Measurement of Glass Stress—Optical Coefficient¹

This standard is issued under the fixed designation C770; the number immediately following the designation indicates the year of original adoption or, in the case of revision, the year of last revision. A number in parentheses indicates the year of last reapproval. A superscript epsilon (ϵ) indicates an editorial change since the last revision or reapproval.

1. Scope

1.1 This test method covers procedures for determining the stress-optical coefficient of glass, which is used in photoelastic analyses. In Procedure A the optical retardation is determined for a glass fiber subjected to uniaxial tension. In Procedure B the optical retardation is determined for a beam of glass of rectangular cross section when subjected to four-point bending. In Procedure C, the optical retardation is measured for a beam of glass of rectangular cross-section when subjected to uniaxial compression.

1.2 *This standard does not purport to address all of the safety concerns, if any, associated with its use. It is the responsibility of the user of this standard to establish appropriate safety and health practices and determine the applicability of regulatory limitations prior to use.*

2. Referenced Documents

2.1 ASTM Standards:²

[C336 Test Method for Annealing Point and Strain Point of Glass by Fiber Elongation](#)

[C598 Test Method for Annealing Point and Strain Point of Glass by Beam Bending](#)

[C1426 Practices for Verification and Calibration of Polarimeters](#)

~~[E218F218 Tentative Standard Method for Radiochemical Determination of Cesium-137 in Aqueous Solutions \(Chloroplatinate Method\)](#)~~ [Test Method for Measuring Optical Retardation and Analyzing Stress in Glass \(Withdrawn 1968\)](#)

2.2

[NIST, Recommended Practice Guide “Fractography of Ceramics and Glasses” \(Section 4.6.2—Flexural Strength\)](#)

3. Significance and Use

3.1 Stress-optical coefficients are used in the determination of stress in glass. They are particularly useful in determining the magnitude of thermal residual stresses for annealing or pre-stressing (tempering) glass. As such, they can be important in specification acceptance.

4. Apparatus

4.1 Stressing Equipment and Polarimeter:

4.1.1 *Procedure A*—[Figs. 1 and 2](#) illustrate a polarimeter employing a quarter-wave plate and rotatable analyzer,³ described in Test Method [E218F218](#). The quarter-wave plate shall be designed for the wavelength of the light being used. The polarizing axes of the polarizer and analyzer shall be set at right angles to each other with each being located at an angle of 45° with the horizontal and vertical. The analyzer, however, shall be mounted in a rotatable mount having a scale graduated on either side from 0 to 180°. The quarter-wave plate shall be fixed to give maximum extinction when the polarizer and analyzer are crossed at right angles; that is, when its polarizing axes are set at 45° and 135° to the horizontal and vertical. In place of the immersion cell *E*, a means of supporting and loading a glass specimen shall be provided, either in air ([Fig. 3\(a\)](#)) or in an immersion liquid ([Fig. 3\(b\)](#)). In this arrangement the optical elements of the polarimeter between light source and telescope have been reversed and a large scale graduated in 2-nm divisions is employed with the rotatable analyzer *I*.

¹ This test method is under the jurisdiction of ASTM Committee C14 on Glass and Glass Products and is the direct responsibility of Subcommittee C14.04 on Physical and Mechanical Properties.

Current edition approved Oct. 1, 2013; May 1, 2016. Published October 2013; June 2016. Originally approved in 1973. Last previous edition approved in 2008; 2013 as C770 – 98 (2008); (2013). DOI: 10.1520/C0770-98R13; 10.1520/C0770-16.

² For referenced ASTM standards, visit the ASTM website, www.astm.org, or contact ASTM Customer Service at service@astm.org. For *Annual Book of ASTM Standards* volume information, refer to the standard's Document Summary page on the ASTM website.

³ The last approved version of this historical standard is referenced on www.astm.org.

³ Goranson and Adams, “Measurement of Optical Path Differences,” *Journal of Franklin Institute*, Vol 216, 1933, p. 475. Goranson and Adams, “Measurement of Optical Path Differences,” *Journal of Franklin Institute*, Vol 216, 1933, p. 475.

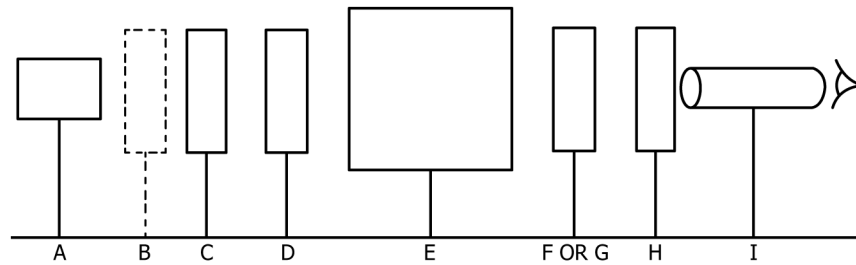

FIG. 1 Polarimeter

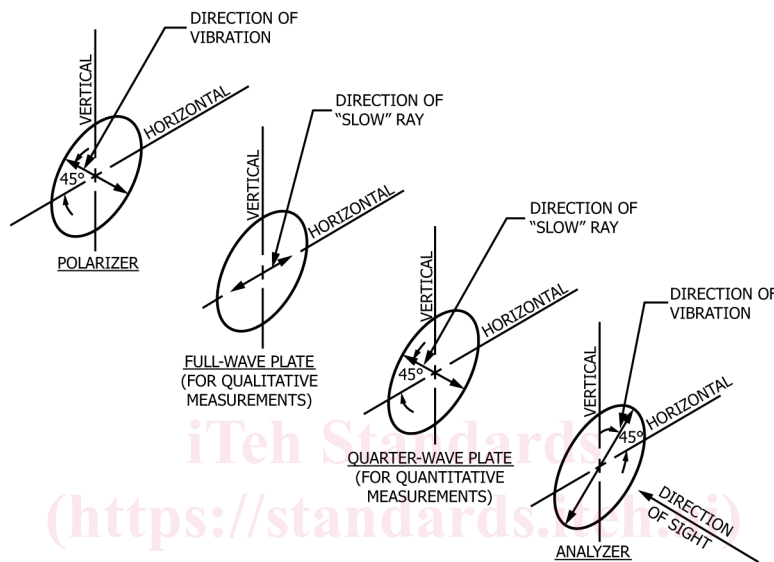

FIG. 2 Orientation of Polarimeter in Standard Position

4.1.1.1 Fig. 3 illustrates the fiber-stressing and optical arrangement used in Procedure A. Figure 3(a) shows the fiber mounted vertically, positioned, and supported by two brass collars with swivel handles so that the kilogram weight may be applied to load the fiber. A light shield having entrance and exit slits surrounds the fiber providing a degree of collimation to the light passing through the fiber and also helping to eliminate stray light.

4.1.1.2 In Fig. 3(b) the fiber is stressed while immersed in a liquid which matches the refractive index of the fiber. This arrangement provides more satisfactory viewing of the fiber.

4.1.2 Procedure B:

4.1.2.1 The polarimetry apparatus for the beam-bending procedure is shown in Fig. 4. Radiation from a white-light source passes through the following components and in this sequence: a diffusing plate, an adjustable aperture, diffuser, a polarizer whose axis is at 45° to the vertical, the glass specimen, a Babinet compensator, a polarizer-quarter-wave plate, and a second polarizer (analyzer) whose axis is at 90° to that of the first polarizer, and a telescope of modest power.

4.1.2.2 A schematic of the loading scheme is shown in Fig. 4(b). Metal fixtures shall be provided to subject the specimen to four-point bending. A support span of 115 mm and a moment arm, a , of 45 mm are recommended. Dimensions within 5% of these values are acceptable. Symmetrical loading is essential, and requires careful centering of the upper loading block. The knife edges shall be finished to approximately 5-mm radius. Loading can be accomplished through a yoke, which rests in a V-groove in the upper loading block, and a weight pan as shown. However, any convenient loading scheme at the center of the upper block may be used.

4.1.2.3 A Babinet compensator is positioned so as to produce vertical fringes (Fig. 4(c)). The neutral fringe must fall near the center of the support span. Recommended fringe spacing is 1000 ± 200 nm of retardation per centimeter. In actual practice the compensator is placed very close to the specimen inside the loading yoke.

4.1.2.3 A telescope is mounted in a rotating collar equipped with an angular scale which can be read to 0.1° polarimeter, with a rotating analyzer, calibrated to Practices C1426 by a vernier. The cross hairs in the eyepiece are, and described in Test Method C1426 and in Section 6 of this test method, is used to measure the tilt angle of the neutral fringe as shown in observe the zero order (black) fringe in the mid-plane of the beam as a known Fig. 4(c). An 80-mm objective lens and 10× eyepiece are adequate components for the telescope. load is applied. The readings from the analyzer scale are used in the calculation of the stress-optical coefficient.

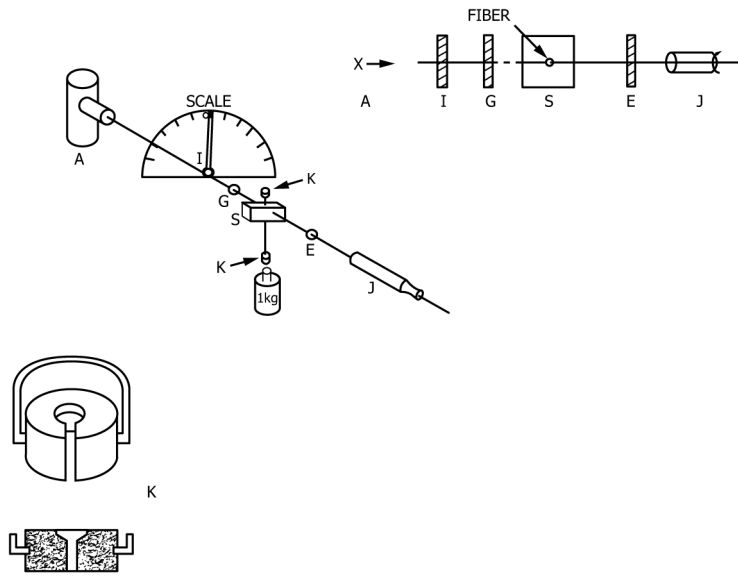

(a) Fiber in Air (Top View, Optical Elements)

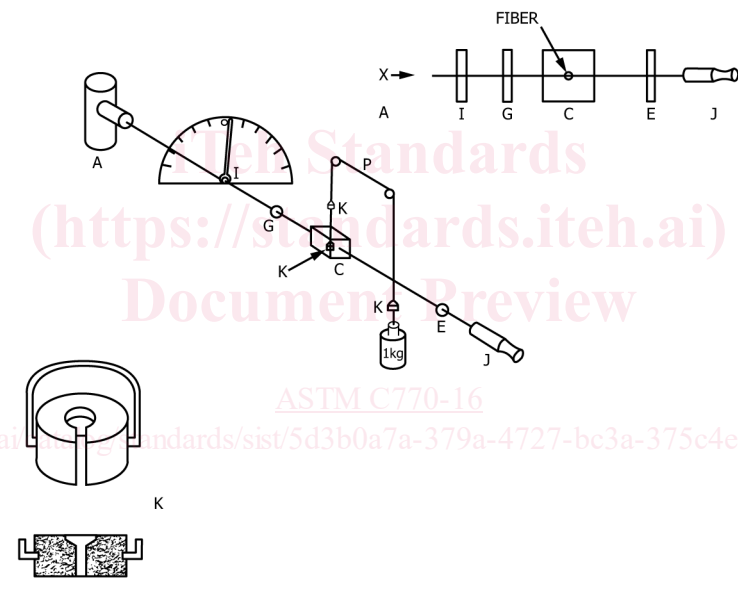

(b) Fiber Immersed

- | | |
|---------------------------------|--------------------|
| A—Light Source | J—Telescope |
| C—Optical cell and index liquid | K—Brass collars |
| E—Polarizer | P—Pulley system |
| G—Quarter-wave plate | S—Shield and slits |
| I—Rotatable analyzer | |

FIG. 3 Optical and Fiber-Stressing Polarimeter Arrangement

4.1.2.5 The adjustable aperture is set at the smallest diameter that permits suitable viewing. As with the fiber apparatus, this provides some collimation and helps to eliminate stray light.

4.1.3 Procedure C:

4.1.3.1 Polarimeter as described in Test Method E218F218.

4.1.3.2 Force application frame, an example of which is shown in Fig. 56(a) and Fig. 6(b), must include:

- A strain-gage load cell and load cell indicator, capable of measuring the force applied within 1 % accuracy.
- Hydraulic or mechanical means of applying constant force and maintaining the force during the measuring time.
- Swivel-mounted loading blocks, offering at least two degrees of swivel freedom, to avoid the loading on the edge.

4.2 Micrometer Caliper, for measuring specimen dimensions to 0.0025 mm (0.0001 in.).

4.3 Weights that are known to an accuracy of ± 1 %.

a—Moment arm
 A—Light Source
 B—Adjustable aperture
 C—Polarizer
 D—Beam
 E—Loading fixtures

F—Yoke and weight pan
 G—Babinet compensator
 H—Polarizer
 I—Telescope and angular scale
 L—Load
 θ —Tilt angle of neutral fringe



FIG. 4 Optical and Mechanical Details for Beam Method Typical Beam-Bending and Polarimeter Apparatus

5. Test Specimen

5.1 Procedure A:

5.1.1 Select a mass of the glass to be tested that has good optical quality with no heavy cords or striae. By conventional lamp-working methods, draw 0.6 to 0.9 m (2 to 3 ft) of fiber from the glass, sufficient to provide five specimens 76 to 102 mm (3 to 4 in.) long with taper (variation in diameter along the length) less than 0.025 mm (0.001 in.) and diameters in the range 0.635 mm (0.025 in.) to 0.760 mm (0.030 in.). The difference in mutually perpendicular diameters at any point along the specimen length shall be less than 0.0076 mm (0.0003 in.).

5.1.2 Bead both ends of each specimen by holding the end in a flame with the fiber vertical until a bead of two to three fiber diameters forms.

5.1.3 Anneal the specimens together so as to remove most of the lamp-working stress (Annex A2).

5.2 Procedure B:

5.2.1 Select a mass of glass to be tested that has good optical quality with no heavy cords or striae. By conventional grinding methods, prepare a beam of rectangular cross section. The width of the beam shall be within the range 20 to 30 mm (0.8 to 1.2 in.), the thickness within the range 6 to 10 mm (0.25 to 0.40 in.), and the length within the range 120 to 130 mm (4.75 to 5.10 in.). Use a fine grind for the upper and lower surfaces (as the beam sits on the loading fixture) and polish the viewing surfaces. The ends need not be finished and a simple saw cut will suffice. The four major surfaces shall be flat and parallel to within 0.050 mm (0.002 in.).

5.2.2 Before final finishing, fine anneal the glass (Annex A2) to such a degree that when the specimen is placed in the fixture unloaded there is very little curvature to the portion of the neutral fringe that appears within the specimen. (with the analyzer at zero), there is a uniformly dark field with no difference between the specimen and the background.

5.3 Procedure C (Rectangular Beam Method):

5.3.1 The thickness of the specimen (see Fig. 67) should be no less than 5 mm ($\frac{3}{16}$ in.).

5.3.2 The width should be no less than 10 mm ($\frac{3}{8}$ in.).

5.3.3 The length of the specimen should be larger than 4 \times width, but not longer than 60 \times thickness, to avoid buckling failures.

5.3.4 Both ends must be ground finished flat and parallel, within 0.1 mm (0.004 in.).

5.4 Procedure C (Glass Disc Method):

5.4.1 The thickness of the specimen should be 5 to 10 mm (0.2 to 0.4 in.)

5.4.2 The diameter should be nominally 12.7 mm (1/2 in.) (Accurate diameter needed for calculation.)

5.4.3 The disc should be isotropic and homogenous, core drilled with both faces polished and parallel.

6. Procedure

6.1 Procedure A:

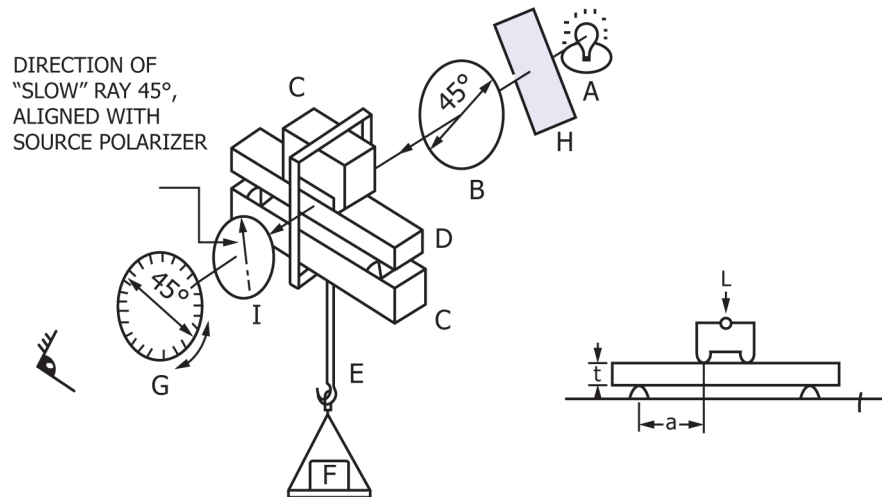

FIG. 5 Schematic of 4-Point Beam Loading System

6.1.1 Mount the fiber specimen vertically by the beaded end in the test fixture so that approximately the midlength is in the polariscope light beam and the fiber image is clearly in focus.

6.1.2 Adjust the light shield or aperture so that the slits are in the line of sight when viewing the fiber through the telescope.

6.1.3 Rotate the polarimeter analyzer until a bright area or line is visible, centered in the fiber cross section and parallel to its sides (the “image” of the light source that the cylindrical fiber “lens” tends to form).

6.1.4 Rotate the analyzer until the bright line becomes darkest or reaches extinction. Record the retardation indicated on the polarimeter scale either in degrees or nanometres. Repeat five times to obtain an average “zero” scale reading, \bar{r}_0 . Normally, this will be near the scale zero for a relatively unstressed fiber and may be in the direction of rotation which indicates vertical tension. Since 180° of rotation covers a retardation of one full wavelength each angular degree corresponds to 3.03 nm, if light of a wavelength of 546 nm is used.

6.1.5 Add a 10 N (2.25 lb) weight to the fiber loading suspension of the test fixture. Rotate the analyzer in the tension direction (Annex A1) until extinction again occurs and record the retardation indicated. Repeat this rotation about five times and obtain an average scale reading, \bar{r} .

6.1.6 Remove the fiber, measure, and record to the nearest 0.0025 mm (0.0001 in.) the average diameter, \bar{d} (average of diameters parallel and perpendicular to light path) at the position where retardation was measured.

6.1.7 Repeat this procedure with the other fiber specimens.

6.2 Procedure B:

6.2.1 With the specimen removed from the polarimeter, set the reference cross hair on and parallel to the black neutral fringe. Simultaneously set the angle to zero on the rotatable reference scale analyzer at zero degrees and observe a uniform dark field, indicating a no-stress condition.

6.2.2 Place Before placing the specimen on in the metal loading support and then position the upper loading block. After careful positioning, engage the loading yoke and weight pan. Record the combined weight of the loading fixture, record the combined weight (in Newtons) of the loading fixture, including the upper block, yoke, weight pan, and coupling fixtures which is fixtures, load L_1 . This must be known to an accuracy of $\pm 1\%$, $\pm 1\%$. Place the specimen on the loading support and position the upper loading block.

6.2.3 With the polarized illuminator on and the light path perpendicular to the polished surfaces of the sample, slowly rotate the analyzer until the observed light intensity of the background is at minimum (dark field). In this position, the polarizing axes of the analyzer and polarizer are mutually perpendicular (crossed) with the rotating analyzer scale at zero.

6.2.4 Measure the angle of tilt (Annex A1) of the neutral fringe analyzer caused by the load L_1 and record this angle as θ_1 . Slowly rotate the analyzer in a clockwise direction until the top edge of the beam exhibits minimum light intensity. A standard wavelength (~565 nm CWL) bandpass filter may be used to improve visualization of the neutral fringe under an added load.

6.2.5 Add a 10 N (2.25 lb) weight. Record the total load certified weight to the weight pan L_2 and measure and record the resulting angle θ_2 , resulting angle θ and total load L_2 .

6.2.6 Increase the load in 10 or 20 N steps, measuring and recording the resulting associated incremental loads and the resulting tilt angles, θ , until a maximum load of about 70 N (15.7 lb) is reached.

6.2.7 Plot the tangent of the tilt analyzer angle, θ , as a function of load as shown in Fig. 78. Draw the best straight line through the data and determine the average slope, S (Annex A3).

6.3 Procedure C:

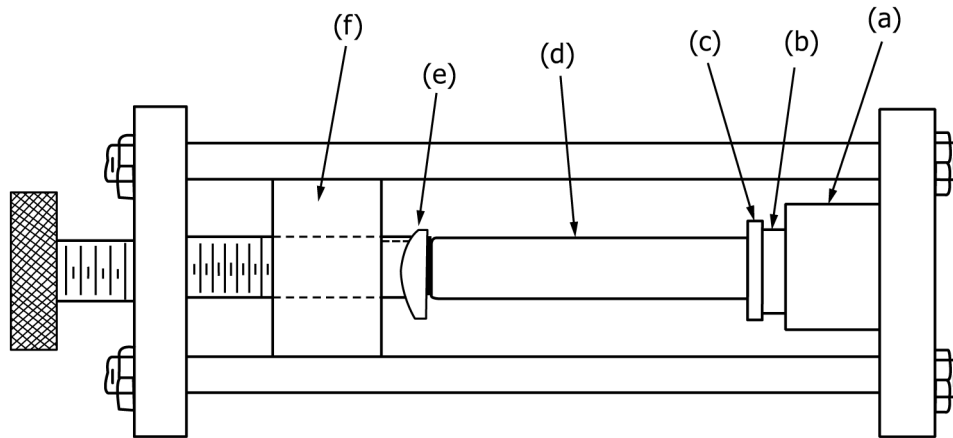

- (a) Load-Cell
- (b) Swivel
- (c) Pressure-Plate
- (d) Specimen
- (e) Spherical-Washer
- (f) Axial-Bearing

- (a) Load Cell
- (b) Swivel
- (c) Pressure Plate
- (d) Specimen
- (e) Spherical Washer
- (f) Axial Bearing

FIG. 56 (a) Force Application Frame

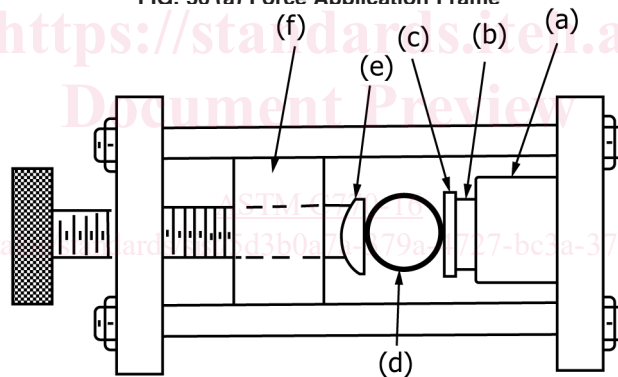

- (a) Load Cell
- (b) Swivel
- (c) Pressure Plate
- (d) Specimen
- (e) Spherical Washer
- (f) Axial Bearing

FIG. 6 Compression-Specimen(b) Force Application Frame (Glass Disc Method)

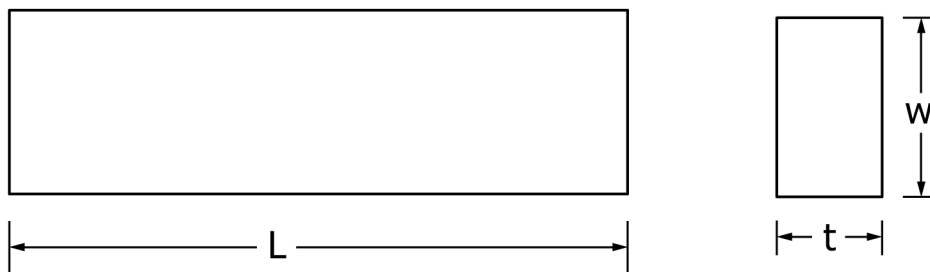

(a) Beam-Stressing-and-Polarimeter-Arrangement
 FIG. 7 Rectangular Compression Specimen