



Designation: ~~D7158/D7158M~~ – 11 D7158/D7158M – 16

Standard Test Method for Wind Resistance of Asphalt Shingles (Uplift Force/Uplift Resistance Method)¹

This standard is issued under the fixed designation D7158/D7158M; the number immediately following the designation indicates the year of original adoption or, in the case of revision, the year of last revision. A number in parentheses indicates the year of last reapproval. A superscript epsilon (ϵ) indicates an editorial change since the last revision or reapproval.

1. Scope

1.1 This test method covers the procedure for calculating the wind resistance of asphalt shingles when applied in accordance with the manufacturer's instructions, and sealed under defined conditions. Shingle designs that depend on interlocking or product rigidity to resist the wind cannot be evaluated using this test method. The method calculates the uplift force exerted on the shingle by the action of wind at a specified velocity, and compares that to the mechanical uplift resistance of the shingle. A shingle is determined to be wind resistant at a specified basic wind speed when the measured uplift resistance exceeds the calculated uplift force for that velocity (3-second gust, ASCE 7).

1.2 The values stated in either SI units or inch-pound units are to be regarded separately as standard. The values stated in each system may not be exact equivalents; therefore, each system shall be used independently of the other. Combining values from the two systems may result in non-conformance with the standard.

1.3 *This standard does not purport to address all of the safety concerns, if any, associated with its use. It is the responsibility of the user of this standard to establish appropriate safety and health practices and determine the applicability of regulatory limitations prior to use.*

2. Referenced Documents

2.1 *ASTM Standards:*²

~~D225~~ D228/D228M Specification for Asphalt Shingles (Organic Felt) Surfaced With Mineral Granules (Withdrawn 2012)³

~~D316~~ D3161/D3161M Test Methods for Sampling, Testing, and Analysis of Asphalt Roll Roofing, Cap Sheets, and Shingles Used in Roofing and Waterproofing

~~D1079~~ Terminology Relating to Roofing and Waterproofing

~~D346~~ D3462/D3462M Test Method for Wind-Resistance of ~~Asphalt Shingles~~ Steep Slope Roofing Products (Fan-Induced Method)

~~D638~~ D6381/D6381M Specification for Asphalt Shingles Made from Glass Felt and Surfaced with Mineral Granules

~~D638~~ D6381/D6381M Test Method for Measurement of Asphalt Shingle Mechanical Uplift Resistance

2.2 *ASCE Standard:*⁴

~~ASCE 7-02~~ ASCE 7-10 Minimum Design Loads for Buildings and Other Structures

ASCE 49-12 Wind Tunnel Testing for Buildings and Other Structures

2.3 *ANSI/UL Standard:*

ANSI/UL 2390-04 Test Method for Wind Resistant Asphalt Shingles with Sealed Tabs⁵

3. Terminology

3.1 *Definitions:*

3.1.1 For definition of terms used in this test method, refer to Terminology D1079.

3.2 *Definitions of Terms Specific to This Standard:*

¹ This test method is under the jurisdiction of ASTM Committee D08 on Roofing and Waterproofing and is the direct responsibility of Subcommittee D08.02 on Steep Roofing Products and Assemblies.

Current edition approved ~~Jan. 1, 2011~~ May 1, 2016. Published ~~January 2011~~ June 2016. Originally approved in 2005. Last previous edition approved in ~~2008~~ 2011 as ~~D7158-08~~ D7158/D7158M-11. DOI: ~~10.1520/D7158_D7158M-11~~ 10.1520/D7158_D7158M-16.

² For referenced ASTM standards, visit the ASTM website, www.astm.org, or contact ASTM Customer Service at service@astm.org. For *Annual Book of ASTM Standards* volume information, refer to the standard's Document Summary page on the ASTM website.

³ The last approved version of this historical standard is referenced on www.astm.org.

⁴ Available from American Society of Civil Engineers (ASCE), 1801 Alexander Bell Dr., Reston, VA 20191, <http://www.asce.org>.

⁵ Available from American National Standards Institute (ANSI), 25 W. 43rd St., 4th Floor, New York, NY 10036, <http://www.ansi.org>.

3.2.1 *sealant*—as it relates to steep roofing shingles, is defined as factory-applied or field-applied typically asphaltic material designed to seal the shingles to each other under the action of time and temperature after the shingles are applied to a roof.

3.2.2 *seal*—as it relates to steep roofing shingles, is the bonding that results from the activation of the sealant under the action of time and temperature.

3.2.3 *sealed*—the condition of the shingles after they are subjected to the conditioning procedure described in 10.3.

4. Types and Classes of Shingles

4.1 Shingles are classified based on their resistance to wind velocities determined from measured data (Section 11), calculations of uplift force (Section 12), and interpretation of results (Section 13), as follows:

4.1.1 *Class D*—Passed at basic wind speeds up to and including ~~145~~185 km/h [~~90~~115 mph].

4.1.2 *Class G*—Passed at basic wind speeds up to and including ~~193~~241 km/h [~~120~~150 mph].

4.1.3 *Class H*—Passed at basic wind speeds up to and including ~~242~~306 km/h [~~150~~190 mph].

5. Summary of Test Method

5.1 The uplift force induced by wind passing over the surface of asphalt shingles is determined by calculation involving the uplift coefficients obtained from pressures measured above and below the shingle at the windward and leeward sides of the sealant, taking into account the desired basic wind speed classification and the uplift rigidity of the shingle. The calculated uplift force (F_T) for each of the possible classifications is compared to the measured uplift resistance (R_T) of the sealed shingle to establish the wind resistance classification of the shingle.

5.2 The method involves three steps:

5.2.1 Uplift coefficients are determined by measuring pressure differences above and below the shingle as air moves over the surface of a deck of sealed shingles under controlled conditions.

5.2.2 The uplift forces acting on the shingle are calculated, using the wind uplift coefficients, shingle sealant configuration and a specific basic wind speed.

5.2.3 Shingle uplift resistance to that specific basic wind speed is determined by comparing the calculated uplift forces acting on the sealant to the uplift resistances measured with Test Method ~~D638~~D6381/D6381M. Uplift resistances from Procedure A and Procedure B are applied against the uplift forces in a manner detailed in the calculation section.

5.3 This test method is applicable to any asphalt shingle surfaced with mineral granules where the shingle above is affixed to the surface of the shingle below with a sealant (factory or field applied) applied in a pattern aligned parallel to the windward edge of the shingle.

NOTE 1—It is not prohibited to use this test method for research purposes using variations in the number and placement of fasteners. If this is done, the report shall include details of the number and placement of fasteners.

6. Significance and Use

6.1 The wind resistance of sealed asphalt shingles is directly related to the ability of the sealed shingle to resist the force of the wind acting to lift the shingle from the shingle below. This test method employs the measured resistance of the shingle to mechanical uplift after sealing under defined conditions, in a calculation which determines whether this resistance exceeds the calculated force induced by wind passing over the surface of the shingle. Natural wind conditions differ with respect to intensity, duration, and turbulence; while these conditions were considered, and safety factors introduced, extreme natural variations are beyond the means of this test method to simulate.

6.2 Many factors influence the sealing characteristics of shingles in the field; for example, temperature, time, roof slope, contamination by dirt and debris, and fasteners that are misaligned or under driven and interfere with sealing. It is beyond the scope of this test method to address all of these influences. The classification determined in this test method is based on the mechanical uplift resistance determined when representative samples of shingles are sealed under defined conditions before testing.

6.3 The calculations that support the Classes in 4.1 use several standard building environment factors. These include the 3-s wind gust exposure from ASCE-7, ASCE 7-10, installation on Category I or ~~H~~through IV buildings for all slopes, surface ground roughness B or C, and installation on buildings 60 ft tall or less.

NOTE 2—The assumptions used in the calculations for the classes in 4.1 cover the requirements for the majority of the asphalt shingle roofs installed. If environmental factors are outside those used in the calculations for these classes, such as surface ground roughness D, building heights greater than 60 ft tall, building use categories III or IV and other exposures as defined by ASCE-7, ASCE 7-10, other calculations are required. Consult the shingle manufacturer for the specific shingle's DCp, EI, L, L1, and L2 values needed to complete these calculations.

6.4 The test to determine uplift coefficients is conducted with a wind velocity of 15.6 ± 1.3 m/s [35 ± 3 mph]. Research data obtained during the development of this test procedure, as well as standard wind modeling practices, provides for data extrapolation to other wind speeds. In order to simulate the raised shingle edge that is inherent behavior under high wind exposure, shims are inserted under the windward edge of the shingle as appropriate based on wind speed and uplift rigidity of the shingle being investigated. This test method provides a means of measuring shingle uplift rigidity which is used to determine the correct

shim thickness. Additionally, this test method allows for the use of a default value for uplift rigidity (EI) of 7175 N-mm² [2.5 lbf-in.²], if a rigidity measurement is not made. This default value is conservative since the lowest EI measured in the development of this program was 14 350 N-mm² [5.0 lbf-in.²].

NOTE 3—The entire field of wind engineering is based on use of small-scale models in wind tunnels using wind speeds much lower than the full-scale values. Building Codes permit testing of this type to replace the analytical provisions of the Building Code through the provisions of ASCE 7-7-10. (See Appendix X1 for details and references.)

7. Apparatus

7.1 The apparatus described in Test Method ~~D638+D6381/D6381M~~, Procedure A, modified as described below, is used to determine the uplift rigidity of the shingle being evaluated.

7.2 The apparatus described in Test Method ~~D316+D3161/D3161M~~, modified as described below, is used to determine the wind uplift coefficient of the shingle being evaluated.

7.3 Air flow instrumentation capable of continuously measuring and recording time-averaged velocity accurate to ± 0.45 m/s [± 1.0 mph] and a method of traversing the measurement device above the test deck is used to measure velocities of the air flow.

7.4 Air pressure instrumentation capable of continuously measuring and electronically recording the time-averaged pressures of 2.5 to 311 Pa [0.01 to 1.25 in. of water] is used to measure the pressure above and below the shingle on the test deck.

7.5 Shims of thickness 1 ± 0.05 mm [0.04 \pm 0.002 in.] and a maximum length and width of 5.1 by 5.1 mm [0.2 by 0.2 in.] are used to lift the windward edge of the shingle during part of the wind uplift coefficient measurements (see 11.2.5). Shims of other thicknesses, but a minimum of 0.1 mm [0.004 in.], and a maximum width and length of 5.1 by 5.1 mm [0.2 by 0.2 in.], are used as required, alone or in combination, to lift the windward edge to the height calculated from the shingle deflection (see 11.2.13).

NOTE 4—The modifications to the Test Method ~~D316+D3161/D3161M~~ apparatus to induce turbulence, the air flow and pressure measurement instrumentation, and the shims employed, are consistent with the procedure developed for Test Method ANSI/UL 2390 for shingle wind resistance testing.

7.6 The apparatus described in Test Method ~~D638+D6381/D6381M~~ is used to determine the mechanical uplift resistance of the shingle being evaluated. The selection of Procedure A or B in Test Method ~~D638+D6381/D6381M~~ is dictated by the magnitude of the forces in front of (F_F) and behind (F_B) the sealant as calculated using the measured wind uplift coefficient and the geometry of the shingle being evaluated (see 12.2).

8. Preparation of Apparatus

8.1 *Shingle Uplift Rigidity*—Use a metal shim 90 by 90 mm [3.5 by 3.5 in.] with thickness equal to or greater than that of the jaw of the pendant clamp in Test Method ~~D638+D6381/D6381M~~ to allow insertion of the jaw of the pendant clamp without deflecting the specimen before the test begins. Insert the shim all the way to the base (“stop”) of the specimen clamp on the lower fixture. The second specimen clamp on the lower fixture is not used in this test. The same “stop” shall be used each time for both the shim and the specimens. See Fig. 1.

8.2 *Shingle Wind Uplift Coefficient:*

8.2.1 Install devices to induce the desired turbulent air flow from the fan-induced wind apparatus used in Test Method ~~D316+D3161/D3161M~~ as follows:

8.2.1.1 Install a turbulence grid as shown in Fig. 2 in the air flow exit orifice of the fan-induced wind apparatus.

8.2.1.2 Install a bridge panel with roughness strips between the air flow orifice of the apparatus used in Test Method ~~D316+D3161/D3161M~~ and the test deck as shown in Fig. 3.

8.2.1.3 The overall arrangement of a modified Test Method ~~D316+D3161/D3161M~~ apparatus is shown schematically in Fig. 4.

8.2.1.4 Test decks shall be constructed in accordance with Test Method ~~D316+D3161/D3161M~~, with the shingles applied in accordance with the manufacturer’s instructions. The test deck sits on an adjustable stand, and is fixed at ~~0-91-m~~910 mm [36 in.] from the air flow orifice. A rigid bridge with roughness strips (as shown in Fig. 4) is placed between the orifice and the test deck, and there is no step between the bridge and the deck. The bridge and the deck are both set at a slope of 1.6 ± 0.5 degrees. A minimum of 4 ft [1.2 m] of clear space shall be maintained at the sides and back of the test panel deck.

8.2.1.5 The measurement area, as shown in Fig. 5, is an area of 305 by 178 mm [12 by 7 in.] with the long direction perpendicular to the airflow. The area is centered 635 mm [25 in.] from either side of the 1.27 m [50 in.] dimension of the test deck. The front edge of the measurement area shall be the first course of shingles located within the measurement area with its windward edge at least 356 mm [14 in.] from the edge of the test deck closest to the air source.

8.2.1.6 Calibrate the air flow as follows: A vertical velocity profile of time-averaged (mean) velocity shall be measured at the center of the measurement area at 12.7 and 25.4 mm [0.5 and 1.0 in.] above the surface, and at every 25.4 mm [1.0 in.] above the previous measurement to a height of 152 mm [6 in.]. The velocity will increase with distance from the surface, reach a peak value, and begin to decrease with additional height. Record the maximum velocity and its height. This maximum velocity shall be at least 15.6 ± 1.3 m/s [35 ± 3 mph]. A horizontal profile of time-averaged velocities across the measurement area shall be made at the height of maximum velocity (see Note 5) in the vertical profile, and progressing in 25.4 mm [1.0 in.] steps in both horizontal

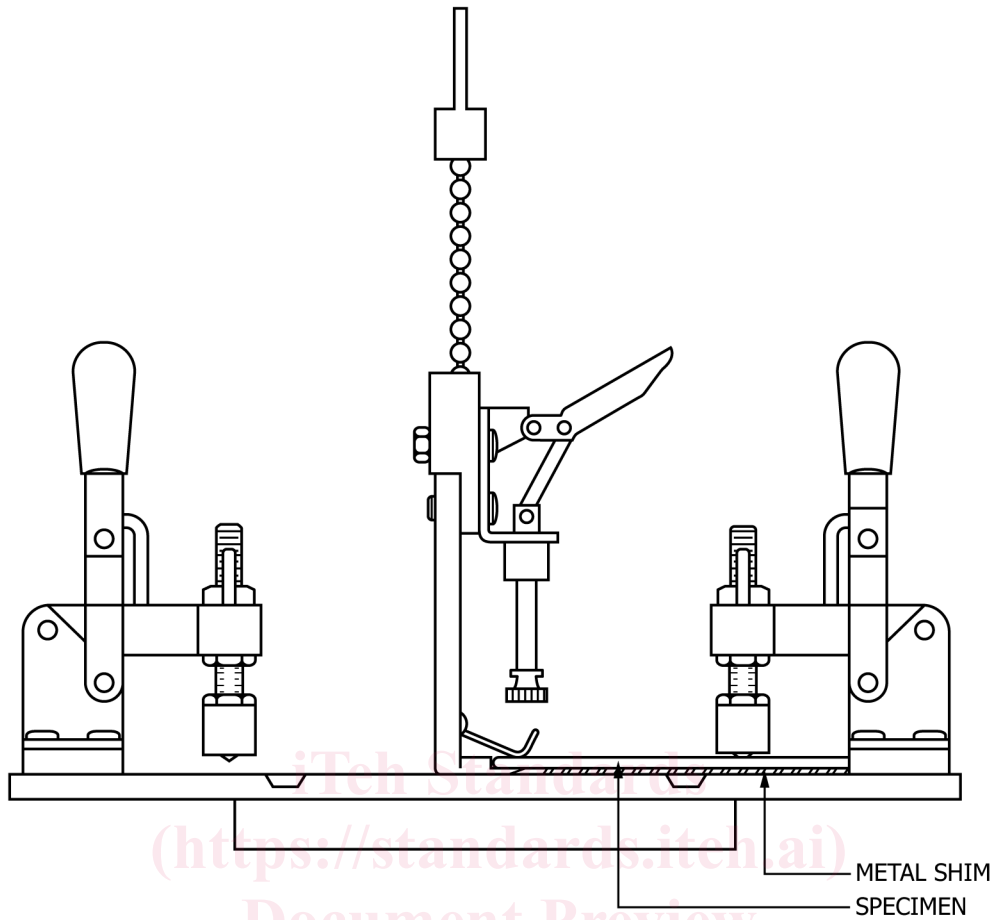
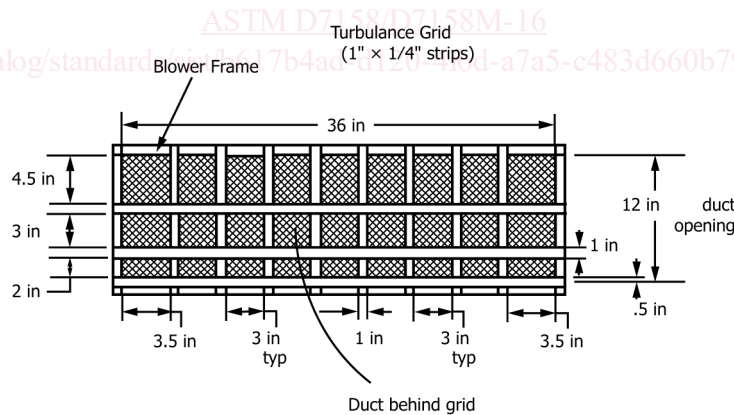

FIG. 1 Apparatus Used in Test Method ~~D6381~~**D6381/D6381M** Modified for this Test Method Using a Metal Shim and Using Only One Specimen Clamp



NOTE 1—1 in. = 25.4 mm.

FIG. 2 Turbulence Grid Installed at Air Flow Exit Orifice of Apparatus Used in Test Method ~~D3161~~**D3161/D3161M**

directions perpendicular to the airflow within the boundaries of the 305-mm [12-in.]-305 mm [12 in.] wide measurement area. All velocities in the horizontal profile shall be within $\pm 5.0\%$ of the maximum velocity recorded in the vertical profile.

NOTE 5—This height has been demonstrated to occur at approximately 102 mm [4 in.].

8.2.2 Installation of Pressure Taps in the Test Decks:

8.2.2.1 Pairs of pressure taps, used to measure uplift pressure, shall be installed in at least four places on one shingle (or section of shingle for multi-layered shingles) (see Fig. 6). Four pairs of taps shall be used when the shingle under test has a single sealant stripe pattern, and two additional pairs of taps shall be installed, on a line centered between the most windward and second-most windward stripes, to measure uplift pressure for shingles with multiple parallel sealant stripe patterns.

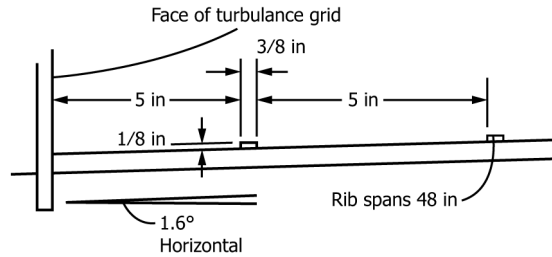

NOTE 1—1 in. = 25.4 mm.

FIG. 3 Bridge Panel with Roughness Strips Installed Between Air Flow Exit Orifice of Apparatus Used in Test Method **D3161**/**D3161M** and Test Deck

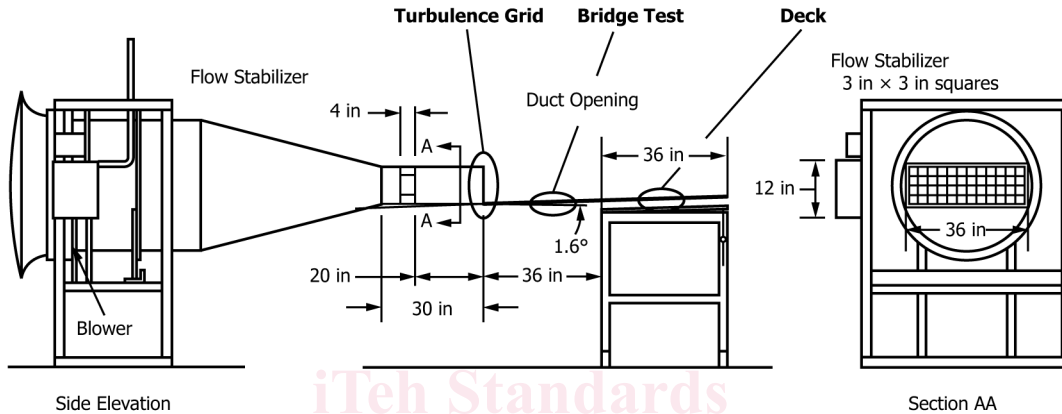

Note: 1 in = 25.4 mm

FIG. 4 Overall Schematic of Test Arrangement for Determination of Wind Uplift Coefficient

8.2.2.2 The first shingle having its windward edge within the measurement area shall be tapped. The distance L shall be measured and recorded. Two lines of pressure taps shall be placed at $L/2$ and at $L/2 + 76$ mm [$L/2 + 3$ in.] from the windward edge. For standard 3-tab shingles, pressure taps shall be placed 51 and 76 mm [2 and 3 in.] on either side of the flow centerline as shown in Fig. 6. In situations where the specified locations do not provide sufficient space for pressure differentials to be determined, other locations near the windward edge and near the center of the shingle that do provide the pressure differentials shall be selected. Additional taps are not prohibited. For laminated tabs, or other tab or sealant designs, the taps shall be located in the same manner, proportioned to the area being measured.

8.2.2.3 Each pressure tap is a tube with ID of 4.9 to 6.4 mm [0.19 to 0.25 in.]. The bottom pressure tap shall have a tube long enough to project below the sheathing panel for connection to a pressure measurement device. The top pressure tap shall pass through a hole drilled in the shingle, and sheathing below the shingle, and have a light friction fit, as shown in detail B of Fig. 6. The flexible tubing shall be long enough so that it can maintain connection to a pressure measurement device after moving up with the deflected shingle.

8.2.2.4 A pressure measurement device is connected to each of the pressure tubes below the deck sheathing. The pressure measurement device shall be capable of measuring pressures of 2.5 to 311 Pa [0.01 to 1.25 in. of water]. Time-average pressure measurements shall be made at each tube. Seal each pressure tap tube during measurements of other taps so that no flow occurs through the taps. (Plug or pinch the flexible connecting tube under the deck.)

8.2.3 *Measurements of sealant location* and stripe patterns, which influence the position of the pressure taps, are used in the calculation of wind uplift force.

8.2.3.1 The following information shall be measured, or determined from the manufacturer's installation instructions, for the shingle being evaluated (see Fig. 7):

(1) Exposure—The transverse dimension of the shingle (parallel to the roof slope) not overlapped by the shingle directly above it as installed on the roof.

(2) L —The distance measured from the windward edge of the most windward sealant pattern stripe to the windward edge of the affixed shingle as installed on the roof.

(3) L_1 —The distance measured from the centerline of the sealant stripe pattern to the windward edge of the affixed shingle as installed on the roof. For shingle designs with two or more parallel stripes of sealant, the distance is measured from the centerline of the most windward strip of sealant to the windward edge of the affixed shingle as installed on the roof.

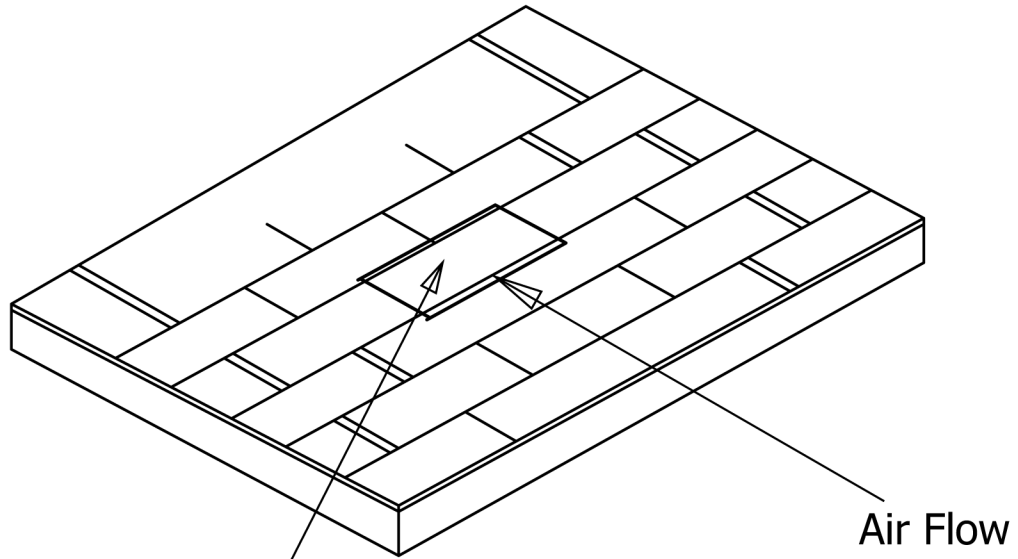

Measurement Area

iTeh Standards
(<https://standards.itih.ai>)
Document Preview

ASTM D7158/D7158M-16

<https://standards.itih.ai/catalog/standards/sist/b617b4ad-d120-4f6d-a7a5-c483d660b79a/astm-d7158-d7158m-16>

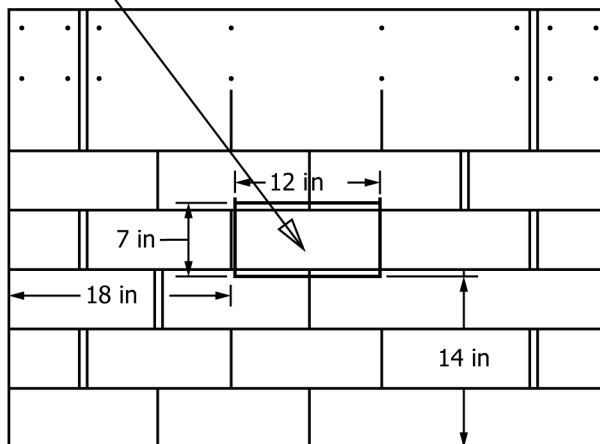

NOTE: 1" = 25.4 mm

FIG. 5 Typical Test Deck Showing Area where Measurements are Made Using Pressure Taps

(4) L2—The distance measured from the centerline of the sealant stripe pattern of the affixed shingle to the windward edge of the shingle directly above as installed on the roof. For shingle designs with two (or more) parallel stripes of sealant, the distance

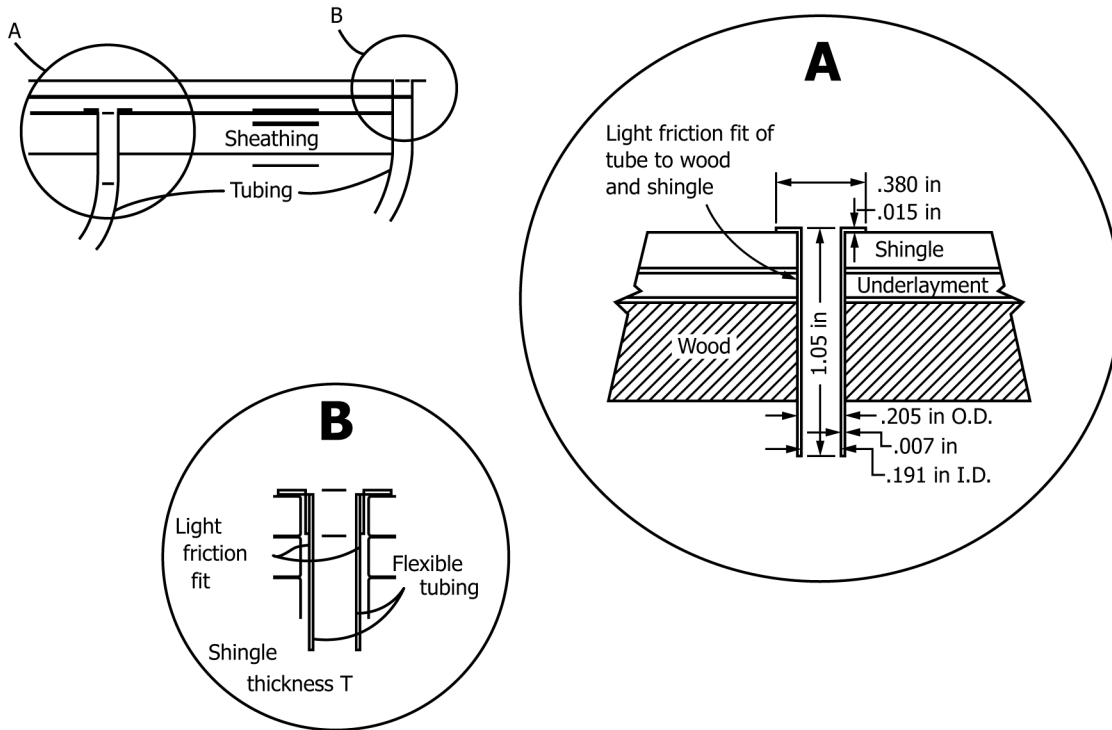

iTeh Standards
(<https://standards.itih.ai>)
Document Preview

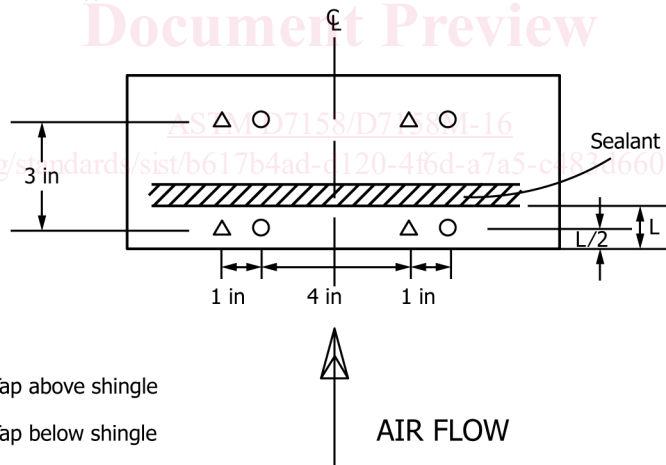

Note: 1 in = 25.4 mm

FIG. 6 Pressure Tap Details and Installation Locations on Selected Shingle in Measurement Area (Single Stripe Sealant Pattern Shown)

is measured from the centerline of the second (from the windward) stripe of sealant of the affixed shingle to the windward edge of the shingle directly above as installed on the roof.

(5) L3—The distance from centerline to centerline of the two most windward sealant stripes for those shingle designs that include two (or more) parallel stripes of sealant.

8.3 *Shingle Mechanical Uplift Resistance*—Prepare the apparatus of Test Method [D6381/D6381M](#) to perform procedure A or B as dictated by the results of the wind uplift coefficient measurements and the shingle geometry (see 12.2).

9. Sampling, Test Specimens, and Test Units

9.1 Shingle Uplift Rigidity:

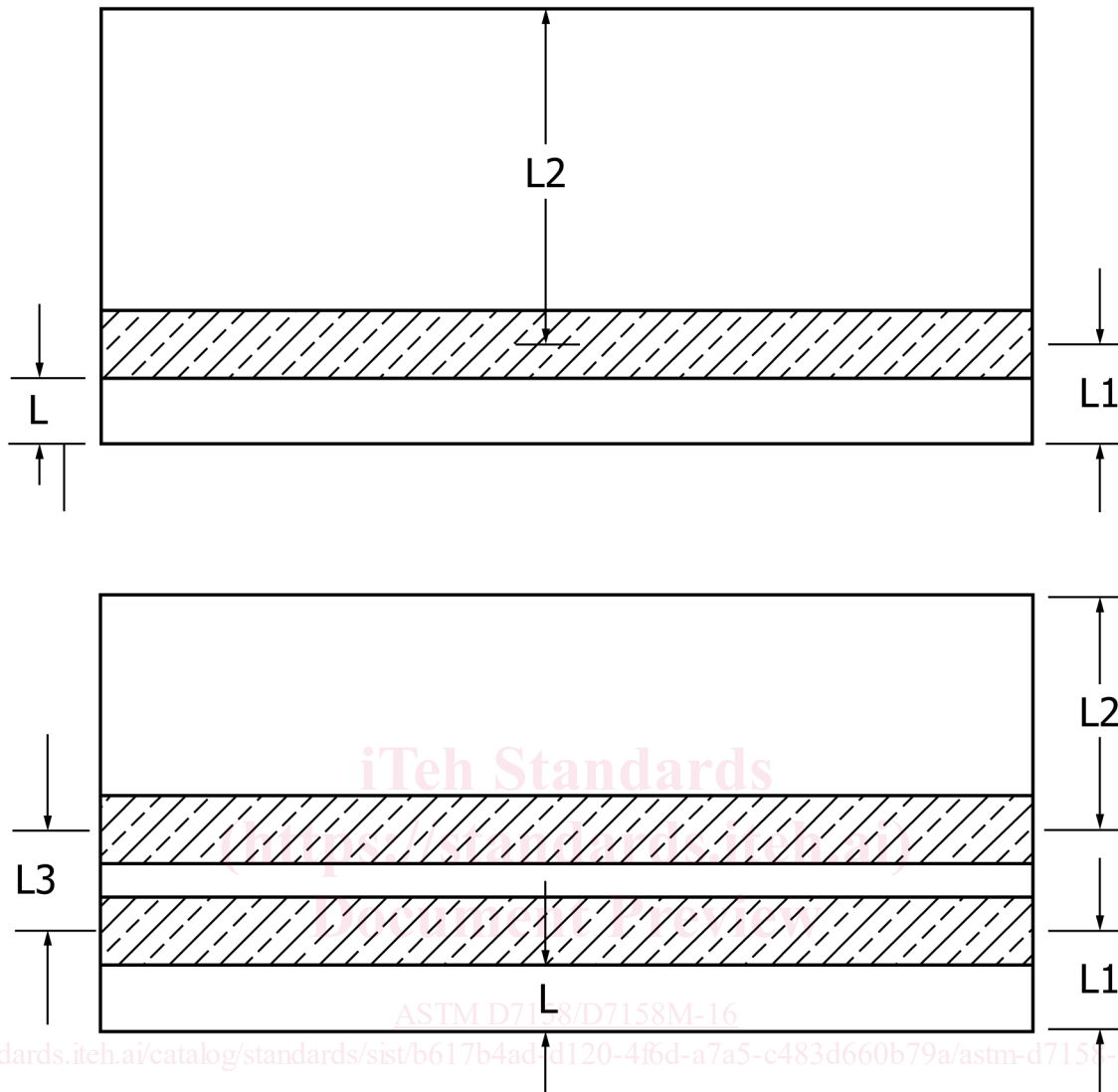

FIG. 7 Measurements Required for Calculation of Uplift Coefficients for Shingles with Single and Double Sealant Stripe Configurations

9.1.1 Ten representative samples for test shall be selected using the sample selection procedures in Test Methods ~~D228~~D228/D228M. Specimens shall be cut from the windward edge of the representative shingle samples.

9.1.2 The test specimens shall be 95 by 102 mm [$3\frac{3}{4}$ by 4 in.] with one of the 95 mm sides being representative of the windward edge (lower exposed edge) of the shingle.

9.2 *Shingle Wind Uplift Coefficient:*

9.2.1 Prepare the test decks for determination of the wind uplift coefficient in accordance with Test Method ~~D316~~D3161/D3161M except as described below. Four decks are required for each shingle being evaluated.

9.2.2 Install pressure taps as directed in 8.2.2 before the deck is sealed.

9.2.3 Install shims as directed in 11.2.4 after the deck is sealed, and after testing in the un-shimmed condition, in 11.2.2.

9.3 *Shingle Mechanical Uplift Resistance:*

9.3.1 Sample in accordance with Test Method ~~D638~~D6381/D6381M using Procedure A or B as dictated by the measured wind uplift coefficients and the shingle geometry (see 12.2).

10. **Conditioning**

10.1 Condition the specimens for determination of shingle uplift rigidity on a flat surface at $23 \pm 2.5^\circ\text{C}$ [$73 \pm 4^\circ\text{F}$] for at least 2 h, and conduct the test at the same temperature.

10.2 Condition the test panel for determining the wind uplift coefficient in accordance with Test Method ~~D316~~D3161/D3161M.

10.3 Seal the specimens for mechanical uplift testing at a temperature of 57 to 60°C [135 to 140°F] for a continuous period of 16 h.

10.3.1 After sealing, condition the specimens for the shingle mechanical uplift test at $23 \pm 2.5^\circ\text{C}$ [$73 \pm 4^\circ\text{F}$] for at least 1h and conduct the test at the same temperature.

11. Procedure

11.1 Determination of the Shingle Uplift Rigidity (EI):

11.1.1 The value for shingle uplift rigidity (EI) needed in the calculation of the wind uplift coefficient shall be determined by one of two methods: (a) testing shingle rigidity in accordance with the following sections, or (b) by selecting a conservative value of $7175 \text{ N}\cdot\text{mm}^2$ [$2.5 \text{ lbf}\cdot\text{in.}^2$] for shingles that comply with Specifications [D225](#) or [D3462/D3462M](#).

11.1.2 The conditioned shingle specimen, weather-side up, is inserted in the Test Method [D6381/D6381M](#) fixture (see [Fig. 1](#)) over the shim, with the specimen's leading edge overhanging the shim near the centerline of the device and with its side edges flush with both the shim and the fixture. This overhang provides space for the bottom portion of the pendant clamp to be inserted without lifting the specimen. Specimens with sealant on their lower surface shall have the sealant covered by release paper or film to prevent sticking to the fixture or shim.

11.1.3 Specimens shall be tested by clamping them (see [Fig. 1](#)) and measuring the distance, l_{test} , from their leading edge (the windward edge) to the front edge of the clamp. A load is then uniformly applied to lift the free, unclamped, leading edge, and the load required to deflect the shingle by specified amounts is measured.

11.1.4 The "load versus deflection" data, averaged from ten tests shall be used to calculate the in-place (that is, applied to roof) shingle uplift rigidity (EI).

11.1.5 The tester shall be zeroed with the top (pendant) assembly hanging freely. At the start of the test, the lower fixture will support the pendant assembly so that the load reading will be negative. As the test progresses (the crosshead moves) the load will pass through zero, and this becomes the "zero" point for measuring both load and deflection.

11.1.6 Record the following information required to calculate the shingle uplift rigidity.

11.1.6.1 The distance, l_{test} , from the exposed end of the specimen to the front edge of the clamp holding the specimen in place on the fixture (measured to the nearest 1 mm [0.04 in.]),

11.1.6.2 Δf , the load at deflections of 5 and 13 mm [0.2 and 0.5 in.], and

11.1.6.3 $\Delta\delta$, the amount of deflection.

11.1.7 Calculate the average $\Delta f/\Delta\delta$ using the loads recorded at the two specified deflections for the 10 specimens, where:

SI Units:

$$\Delta f \text{ (N)} = \Sigma(f_{13} - f_5)/10 \text{ for } n = 1, 2\dots 10, \text{ and}$$

$$\Delta\delta \text{ (mm)} = \Sigma(\delta_{13} - \delta_5)/10 \text{ for } n = 1, 2\dots 10$$

U.S. Customary Systems Units:

$$\Delta f \text{ (lbf)} = \Sigma(f_{0.5} - f_{0.2})/10 \text{ for } n = 1, 2\dots 10, \text{ and}$$

$$\Delta\delta \text{ (in.)} = \Sigma(\delta_{0.5} - \delta_{0.2})/10 \text{ for } n = 1, 2\dots 10$$

11.1.8 Calculate the shingle uplift rigidity, EI, as follows using the averaged values of $\Delta f/\Delta\delta$ and l_{test} .

$$EI = (\Delta f/\Delta\delta) \cdot (l_{\text{test}}^3)/3 \quad (1)$$

11.2 Determination of the Shingle Wind Uplift Coefficient (DCp):

11.2.1 A minimum of four panels are evaluated without shims and re-evaluated with shims as directed below.

11.2.2 With the test deck in position, and without shingle-lifting shims in place, start the air-flow test apparatus and adjust it to produce an air velocity of $15.6 \pm 1.3 \text{ m/s}$ [$35 \pm 3 \text{ mph}$] as measured at the reference velocity position illustrated in [Fig. 8](#), or positions aligned with each respective set of tap locations. For multi-layer (laminated) shingles, the reference velocity position shall be aligned with the respective set of tap locations. The ambient temperature shall be $23 \pm 3^\circ\text{C}$ [$75 \pm 5^\circ\text{F}$]. (See [Appendix X1](#), Background, to correlate test velocity and design wind speed.)

11.2.3 Measure the mean pressures at each of the pressure taps installed on the deck, and the mean air velocity (U_{ref}) at the reference velocity position. Record the pressures at each tap location at 1-s time intervals for a minimum of 30 s. The mean air velocity (U_{ref}) is not required to be measured at the reference velocity position when the dynamic pressure of the air flow (P) is measured directly at the reference velocity position with a Pitot-static probe using the following equation:

$$P = \frac{1}{2}\rho U_{\text{ref}}^2 \quad (2)$$

where:

P = the mean pressure difference across a Pitot-static probe recorded at 1-s time intervals for a minimum of 30 s,

ρ = air density, and

U_{ref} = mean air velocity, calculated from P above.

For P converted to lbf/ft^2 and U_{ref} to mph , use the numerical coefficient 0.00256 for ($1/2 \rho$).

For P converted to N/m^2 and U_{ref} to m/s , use the numerical coefficient 0.613 for ($1/2 \rho$).

11.2.4 Turn off the airflow and insert shims having thickness of 1.0 mm [0.04 in.] under the windward edge of selected shingles on the test deck to simulate the raised edge of the shingles in high wind. Shim locations at the instrumented shingle are shown in [Fig. 9](#). Place shims immediately in front of the two taps measuring pressure on top of the shingle, and in at least three other

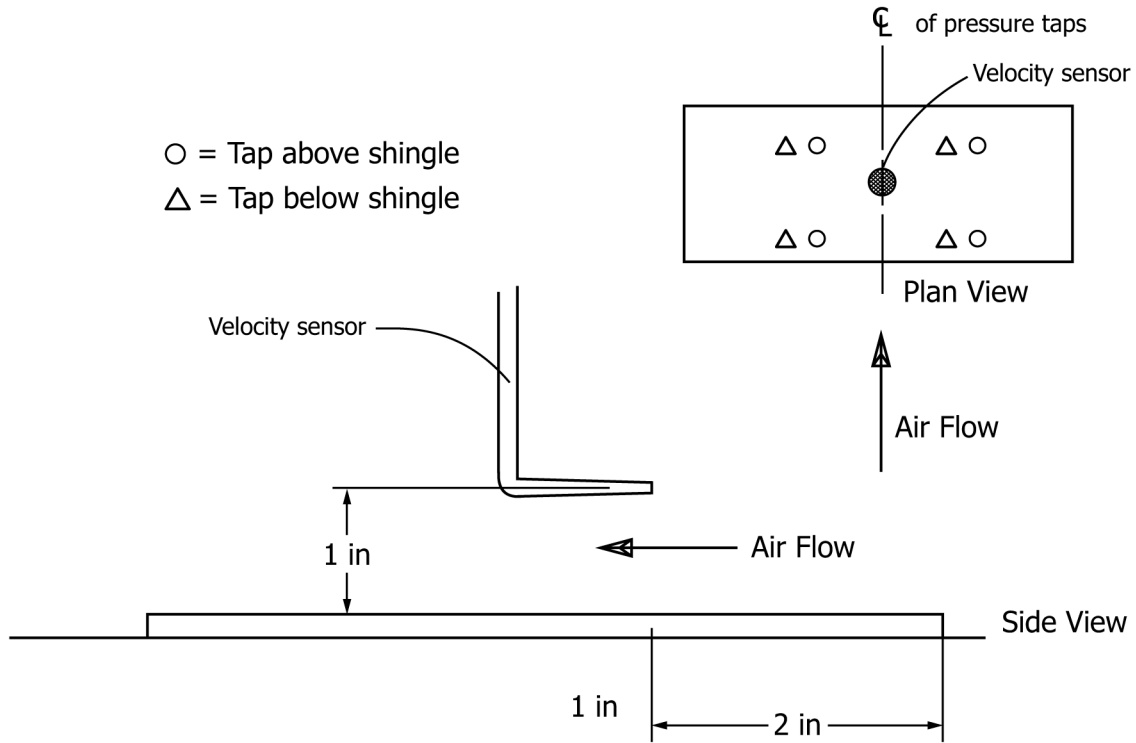

NOTE 1—1 in. = 25.4 mm.

FIG. 8 Velocity Sensor Placement

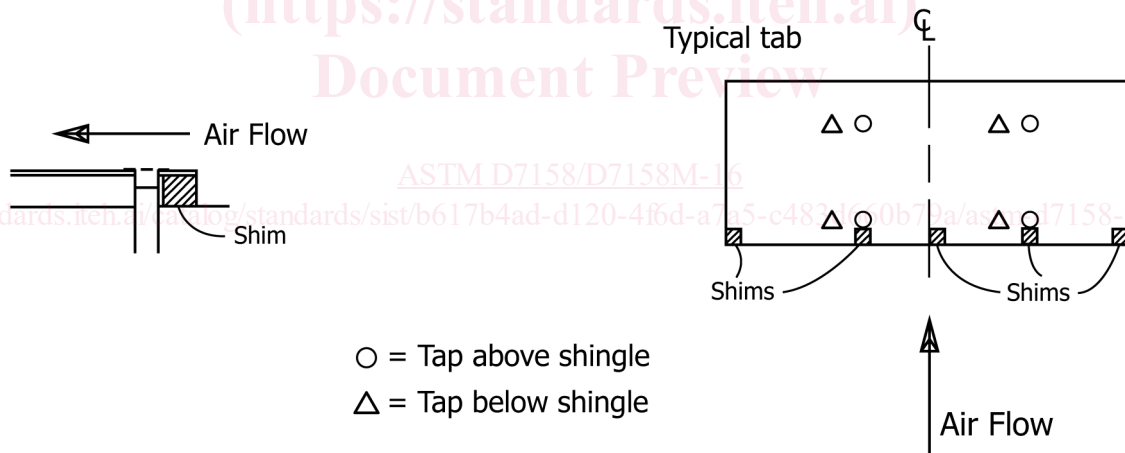

FIG. 9 Placement and Location of Shims in Measurement Area

locations at least 25.4 mm [1.0 in.] away from the shims in front of the pressure taps and from each other, with one of the shims placed between the two pressure-tap shims. The test deck is to be discarded if the sealant bond is damaged due to the placement of the shims. The shims shall be no wider than 5.1 mm [0.2 in.] perpendicular to the air flow, no longer than 5.1 mm [0.2 in.] in the direction of air flow, and not project out past the windward edge of the shingle.

11.2.5 Place shims in similar locations under the windward edge of the shingles in the course directly in front of (to windward) the instrumented shingle.

11.2.6 When open gaps, or overhangs, occur due to a multi-layered shingle design, additional shims, equal in thickness to that of the underlying layer(s), shall be first placed in the gap and then the shims required for the test shall be placed on top of these base shims to provide the desired raised shingle edge.

11.2.7 Repeat the air flow test and make pressure measurements at a velocity of 15.6 ± 1.3 m/s [35 ± 3 mph] with the shims in place. (Standard wind modeling practice provides for data extrapolation to other wind speeds, see ASCE 7-7-10 and ASCE 49-12).