



Designation: D140/D140M – 16

# Standard Practice for Sampling Asphalt Materials<sup>1</sup>

This standard is issued under the fixed designation D140/D140M; the number immediately following the designation indicates the year of original adoption or, in the case of revision, the year of last revision. A number in parentheses indicates the year of last reapproval. A superscript epsilon ( $\epsilon$ ) indicates an editorial change since the last revision or reapproval.

*This standard has been approved for use by agencies of the U.S. Department of Defense.*

## 1. Scope

1.1 This practice applies to the sampling of asphalt materials at points of manufacture, storage, or delivery.

1.2 The values stated in either SI units or inch-pound units are to be regarded separately as standard. The values stated in each system may not be exact equivalents; therefore, each system shall be used independently of the other. Combining values from the two systems may result in non-conformance with the standard.

1.3 *This standard does not purport to address all of the safety concerns, if any, associated with its use. It is the responsibility of the user of this standard to establish appropriate safety and health practices and determine the applicability of regulatory limitations prior to use.*

## 2. Referenced Documents

2.1 *ASTM Standards:*<sup>2</sup>

**D8 Terminology Relating to Materials for Roads and Pavements**

**D346 Practice for Collection and Preparation of Coke Samples for Laboratory Analysis**

## 3. Terminology

3.1 Refer to Terminology **D8**

## 4. Significance and Use

4.1 Sampling is as important as testing, and precautions shall be taken to obtain samples to show the true nature and condition of the materials.

4.2 Samples are taken for either of the following two purposes:

4.2.1 To represent as nearly as possible an average of the bulk of the materials sampled, or

4.2.2 To ascertain the maximum variation in characteristics which the material possesses.

## 5. Precautions

5.1 Because of the numerous types and grades of asphalt materials that are alternately shipped and stored in the same or similar containers, the opportunity for contaminating these containers with residues, precipitates, or cleaning solvents is ever present. Numerous opportunities also exist for obtaining samples which are not strictly representative of the material or are contaminated after removal. Therefore, it is incumbent upon the producer, transporter, user, and sampler to exercise continuous precaution in the sampling and handling of these materials.

## 6. Selection of Samples

6.1 Whenever practicable, asphalt materials shall be sampled at the point of manufacture or storage, and at such time as to allow the tests controlling acceptance or rejection to be made in advance of shipment.

6.2 When the samples cannot be taken at the point of manufacture or storage, they shall be taken from the shipment immediately upon delivery.

## 7. Size of Samples

7.1 The sample size of liquid materials shall be as follows:

7.1.1 For routine laboratory examination and from barrels or drums, 500 mL to 1 L [1 pt to 1 qt].

7.1.2 From bulk storage, 4 L [1 gal].

7.1.3 For emulsified asphalts, 1 L [1 qt].

7.2 The sample size of semisolid or solid materials shall be as follows:

7.2.1 From barrels, drums, or cakes, 1 to 2 kg [2 to 3 lb].

7.2.2 From crushed or powdered material in bulk or bags, 1 to 2 kg [2 to 3 lb].

## 8. Containers

8.1 *Type of Containers:*

<sup>1</sup> This practice is under the jurisdiction of ASTM Committee **D04** on Road and Paving Materials and is the direct responsibility of Subcommittee **D04.30** on Methods of Sampling.

Current edition approved June 1, 2016. Published June 2016. Originally approved in 1922. Last previous edition approved in 2015 as D140/D140M – 15. DOI: 10.1520/D0140\_D0140M-16.

<sup>2</sup> For referenced ASTM standards, visit the ASTM website, www.astm.org, or contact ASTM Customer Service at service@astm.org. For *Annual Book of ASTM Standards* volume information, refer to the standard's Document Summary page on the ASTM website.

8.1.1 Containers for liquid asphalt materials, except emulsified asphalts, shall be wide-mouth cans with lined screw caps or triple-seal friction-top cans.

8.1.2 Containers for emulsified asphalts shall be wide-mouth jars or bottles made of plastic, or wide-mouth plastic-lined cans with lined screw caps, or plastic-lined triple-seal friction-top cans.

8.1.3 Containers for crushed or powdered asphalt materials shall be triple-seal friction-top cans or plastic sacks placed in other containers suitable for handling.

8.2 *Size of Containers*—The size of the container shall correspond to the required sample size.

**9. Protection and Preservation of Samples**

9.1 Sample containers shall be new. They shall not be washed or rinsed, or wiped with an oily cloth. If they contain evidence of solder flux, or if they are not clean and dry, they shall not be used. Top and container shall fit together tightly.

9.2 Care shall be taken to prevent the sample from becoming contaminated. Immediately after filling, the container shall be tightly sealed.

9.3 The filled sample container shall not be submerged in solvent, nor shall it be wiped with a solvent saturated cloth. If cleaning is necessary use a clean dry cloth.

9.4 Samples of emulsified asphalts shall be protected from freezing by correct packaging.

NOTE 1—When sampling emulsified asphalts, care should be taken not to sample material under pressure as such resultant velocities tend to cause air entrapment which could result in erroneous test results. Any visual bubbling of the material is one indication air has been entrapped. In addition, the sampling container should be completely filled to minimize a skin formation at the air-emulsion interface.

9.5 Samples shall not be transferred from one container to another except where required by the sampling procedure.

9.6 Immediately after filling, sealing, and cleaning, the sampling containers shall be properly marked for identification with a suitable marking pencil on the container itself, and not on the lid. Labels or tags also may be used for identification if they can be securely fastened to the container in such a manner as to ensure that they will not be lost in transit. Labels or tags shall not be attached to containers by using the lids to secure them. All identification materials shall maintain their integrity at temperatures up to 200°C [390°F].

9.6.1 The labeling of the sample must, at a minimum, include an identification of the product or material type and the date of sampling.

**10. Sampling at Place of Manufacture**

10.1 *Vertical Tanks Not Capable of Being Agitated (Liquid Materials or Materials Made Liquid by Heating)* (800 m<sup>3</sup> [5000 bbl] or more capacity)—Three sampling methods are recommended (Note 2):

10.1.1 *Sampling-Valve Method*—Valves shall be located, with easy and safe access provided, on the side of the tank with the first in the top third of the tank, but no higher than 1 m [3 ft] from the top; the second in the middle third of the tank; and the third in the bottom third of the tank, but no lower than 1 m

[3 ft] from the bottom. A recommended design of the sampling valve is shown in Fig. 1.

10.1.1.1 A minimum of 4 L [1 gal] of the product shall be drawn from each sample valve and discarded before taking the sample for test in a clean container.

10.1.1.2 500 mL to 4 L [1 pt to 1 gal] shall be drawn from each sample valve for test.

10.1.2 *Thief Sampler Method* (not suitable for asphalt cements)—Samples shall be taken in the top, middle, and lower sections at levels indicated in 10.1.1, of the tank by lowering a thief sampler into the material. A satisfactory type with instructions for use is shown in Fig. 2.

NOTE 2—Most asphalt materials in the liquid state are of such viscous and adhesive character that, after normal emptying of a container by pouring, the container retains enough material to cause significant contamination of any second samples secured before the container was thoroughly cleaned. The aforementioned properties of asphalt materials also make container cleaning a difficult, tedious, and time-consuming task.

NOTE 3—The thief sampler described in Fig. 2 may be used for repetitive sampling because significant sample contamination by previous contents is avoided by the self-cleaning action provided by the passage of material through the tube-shaped thief sampler which is open at both ends. The practice of raising and lowering the sampler 3 or 4 times through a distance of a metre (several feet) at the sampling depth is recommended.

10.1.3 *Throw-Away Container Method*—Samples shall be taken at top, middle, and lower levels by lowering into the material a container in a suitable weighted holding device. The essential feature of the method is to use a clean container to take the sample, pour this sample into another clean container, and throw away the container used to take the sample from the tank. A satisfactory type with instructions on how to use the device is shown in Fig. 3.

10.1.4 The three samples from bulk storage tanks may be tested separately for consistency to detect stratification. They may be combined, thoroughly mixed, and a 500-mL to 4-L [1-pt to 1-gal] sample may be taken for other tests that may be required for determining average characteristics of the material.

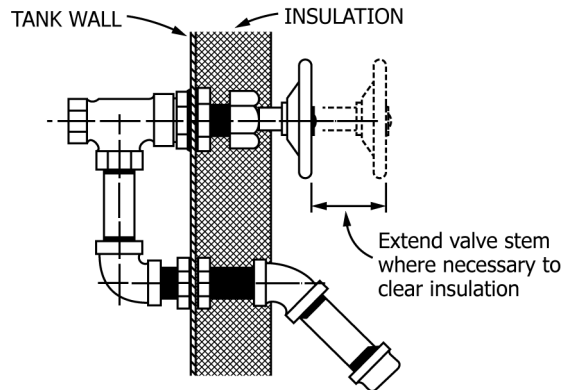
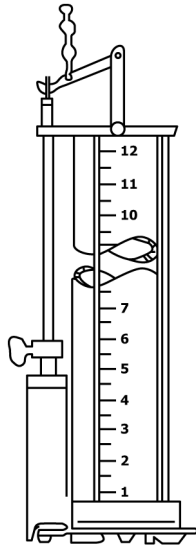

FIG. 1 Typical Submerged Sampling Device



NOTE 1—This type sampler is lowered into the tank with bottom valve open (there is no top closure). When the desired depth is reached, the lowering chain is given a snap tug which closes the bottom valve. The sampler is then withdrawn from the tank and the contents transferred to the sample container. This sampler may be used for repetitive sampling in the same tank.

FIG. 2 Thief Sampler

10.2 *Bulk Storage Tanks (Liquid Materials or Materials Made Liquid by Heating) Equipped with Mechanical Agitators*—When the tank is equipped with operating mechanical agitators which, by observation through the sampling or inspection hatch, are performing adequate mixing of the tank contents, a single sample taken by any of the methods described in 10.1.1, 10.1.2, or 10.1.3 will be satisfactory to use for test purposes.

### 11. Sampling from Tank Cars, Vehicle Tanks, Distributor Trucks or Recirculating Storage Tanks

11.1 The sample may be taken from the sample valve or tap if the tanks are provided with them. When such sampling devices are required, they are to be built into the tank itself. A sampling device of this type is shown in Fig. 1. Before the sample is taken, 4 L [1 gal] shall be drawn from the sample valve and discarded before taking the sample for test in a clean container.

11.2 Samples of liquid materials and materials made liquid by heating may be taken by the dip method using a clean wide-mouth or friction-top can in a suitable holder as shown in Fig. 4. A clean container must be used to take each sample, and the material sampled shall then be transferred to another new and clean container for retention or testing sample.

11.3 A detachable fitting, similar in design to the one shown in Fig. 5 may be inserted in the discharge line. Before the sample is taken 4 L [1 gal] shall be drawn from this sampling valve and discarded before taking the sample in a clean container.

### 12. Sampling from Tankers and Barges

12.1 For liquid materials (including all cut-backs made liquid by heating) top, middle, and lower samples shall be taken using the methods as described in 10.1.2 and 10.1.3.

12.2 For all other materials made liquid by heating, a top sample only shall be taken by the dip, thief, or throw-away container method.

### 13. Sampling from Pipe Lines During Loading or Unloading

13.1 When tankers and barges are being loaded or unloaded samples may conveniently be taken from the pipe line through which the material is flowing by insertion of a sampling pipe into a rising section of the pipe line on the discharge side of the pump or in a completely filled line in which gravity creates the materials flow. A suitable in-line sampling pipe is shown in Fig. 5. The sampling pipe shall be not more than one eighth the diameter of the pipe line and its opening should be turned to face the flow of the liquid. This pipe shall be provided with a valve or plug cock and shall discharge into a sample receiver. At least three 4-L [1-gal] samples shall be taken at uniform intervals throughout the entire loading or unloading. At the completion of the loading or unloading, the individual 4-L [1-gal] samples shall be combined, thoroughly mixed without altering its characteristics, and a 4-L [1-gal] sample taken therefrom.

13.2 When sampling tankers and barges 4000 m<sup>3</sup> [25 000 bbl], or less, capacity, at least five 4-L [1-gal] samples shall be taken at uniform intervals throughout the entire loading or unloading (4000 m<sup>3</sup> [25 000 bbl]), or larger, capacity requires at least ten 4-L [1-gal] samples. At completion of the loading or unloading, the individual 4-L [1-gal] samples shall be combined, thoroughly mixed in a manner designed to not alter its characteristics, and a 4-L [1-gal] sample taken therefrom.

### 14. Sampling from Drums or Barrels

14.1 After thorough mixing, samples of liquid asphalt material from barrels or drums shall be secured by tube or thief sampling by taking 1 L [1 qt] of material from packages selected at random according to Section 15.

### 15. Sampling Semisolid or Uncrushed Solid Materials

15.1 *Drums, Barrels, Cartons, and Bags*—Where the lot of material to be sampled is obviously from a single run or batch of the producer, one package shall be selected at random and sampled as described below. Where the lot of material to be sampled is not obviously from a single run or batch of the producer, or where the single samples selected as described above fails on test to conform to the requirements of the specifications, a number of packages shall be selected at random and equivalent to the cube root of the total number of packages in the lot. The following table is given, showing the number of samples to be selected for shipments of various sizes.