

---

**INTERNATIONAL STANDARD**



**3873**

---

---

## **Industrial safety helmets**

*Casques de protection pour l'industrie*

First edition – 1977-03-01

**iteh STANDARD PREVIEW**  
**(standards.iteh.ai)**

[ISO 3873:1977](https://standards.iteh.ai/catalog/standards/sist/5350c552-96fb-4022-a611-ec8e394b3cb4/iso-3873-1977)

<https://standards.iteh.ai/catalog/standards/sist/5350c552-96fb-4022-a611-ec8e394b3cb4/iso-3873-1977>

---

**UDC 614.891.1.004.1**

**Ref. No. ISO 3873-1977 (E)**

**Descriptors** : accident prevention, protection from falling bodies, safety devices, helmets, specifications.

## FOREWORD

ISO (the International Organization for Standardization) is a worldwide federation of national standards institutes (ISO member bodies). The work of developing International Standards is carried out through ISO technical committees. Every member body interested in a subject for which a technical committee has been set up has the right to be represented on that committee. International organizations, governmental and non-governmental, in liaison with ISO, also take part in the work.

Draft International Standards adopted by the technical committees are circulated to the member bodies for approval before their acceptance as International Standards by the ISO Council.

International Standard ISO 3873 was drawn up by Technical Committee ISO/TC 94, *Personal safety — Protective clothing and equipment*, and was circulated to the member bodies in August 1975.

iteh STANDARD PREVIEW  
(standards.iteh.ai)

It has been approved by the member bodies of the following countries :

Australia	Israel	Spain
Austria	Italy	Sweden
Bulgaria	Mexico	Switzerland
Denmark	Netherlands	Turkey
France	New Zealand	United Kingdom
Germany	Norway	U.S.S.R.
Hungary	Poland	Yugoslavia
Iran	Romania	
Ireland	South Africa, Rep. of	

The member body of the following country expressed disapproval of the document on technical grounds :

Belgium

# Industrial safety helmets

## 1 SCOPE

This International Standard specifies physical and performance requirements, methods of test and marking requirements for industrial safety helmets.

## 2 FIELD OF APPLICATION

The mandatory requirements apply to helmets for general use in industry. Additional optional performance requirements are included to apply only where specifically called for.

## 3 DEFINITIONS

**3.1 safety helmet** : A helmet primarily intended to protect the upper part of a wearer's head against a blow.

**3.2 shell** : The hard, smoothly finished material that provides the general form of the helmet.

**3.3 peak** : A permanent extension of the shell above the eyes.

**3.4 brim** : A rim surrounding the shell.

**3.5 harness** : The complete assembly by means of which the helmet is maintained in position on the head, and which may provide a means of absorbing energy. It consists for example of the following items :

**3.5.1 headband** : The part of the harness surrounding the head at the base of the skull.

**3.5.2 cradle** : The fixed or adjustable assembly of the parts of the harness in contact with the head.

**3.5.3 cushioning** : Material to improve wearing comfort.

**3.5.4 anti-concussion tapes** : Supporting straps which absorb shock.

**3.6 protective padding** : Material contributing to the absorption of kinetic energy during an impact.

**3.7 ventilation holes** : Holes provided in the shell to permit circulation of air inside the helmet.

**3.8 helmet accessories** : Any additional parts for special purposes such as chin strap, neck protector, nape strap, drawlace and attachment devices for lamp and cable.

**3.9 wearing height** : Vertical distance from the lower edge of the headband to the highest point of the head or headform.

**3.10 vertical clearance** : Vertical distance between the top of the headform and the inside of the shell.

**3.11 horizontal clearance** : Horizontal distance between the headband and the inside of the shell or any protruding part of the inside of the shell.

## 4 PHYSICAL REQUIREMENTS

### 4.1 Materials

Recommendations for general consideration of materials are given in annex B.

### 4.2 General construction

Recommendations for general consideration of construction of helmets are given in annex B.

### 4.3 Shell

The shell shall have as uniform a strength as possible and shall not be specially reinforced at any point. This does not exclude a gradual increase in shell thickness or ribs or means for attaching the harness but does exclude other highly localized reinforcement.

The outer surface shall be smoothly finished and all edges shall be smooth and rounded.

The profile at the front edge of the shell shall not prevent the wearing of spectacles or goggles.

### 4.4 Vertical clearance

When measured under the conditions stated in 6.4 the vertical clearance shall be not less than 25 mm and not more than 50 mm.

### 4.5 Horizontal clearance

When measured under the conditions stated in 6.4 the horizontal clearance shall be not less than 5 mm and not more than 20 mm.

iTeh STANDARD PREVIEW  
(standards.iteh.ai)

<https://standards.iteh.ai/catalog/standards/sist/5550c592-961b-4022-a611-ec8e394f3c44/iso-3873-1977>

#### 4.6 Wearing height

When measured under the conditions stated in 6.4 the wearing height shall be not less than :

- 80 mm for helmets mounted on headform D
- 85 mm for helmets mounted on headform G
- 90 mm for helmets mounted on headform K

#### 4.7 Mass

If the mass of a complete helmet, including harness but without accessories, exceeds 400 g, this mass, determined to the nearest 30 g, shall be shown on a label attached to the helmet.

### 5 PERFORMANCE REQUIREMENTS

#### 5.1 Mandatory requirements

##### 5.1.1 Shock absorption

When tested by the method given in 6.5 at low and high temperatures and in moist conditions, the force transmitted to the headform shall not exceed 5,0 kN or the deceleration of the 5 kg striker shall not exceed  $100 g_n$ .

##### 5.1.2 Resistance to penetration

When the helmet is tested by the method given in 6.6 the point of the striker shall not contact the surface of the headform.

##### 5.1.3 Flame resistance

When tested by the method given in 6.7 the material of the shell shall not burn with the emission of flame after a period of 5 s has elapsed after removal of the flame.

#### 5.2 Optional requirements

##### 5.2.1 Low temperature tests

With the conditioning temperature lowered to  $-20\text{ }^{\circ}\text{C}$ , helmets tested for shock absorption in accordance with 6.5 and for resistance to penetration in accordance with 6.6 shall meet the requirements of 5.1.1 and 5.1.2 respectively.

Helmets claimed to meet these requirements shall state this fact on the label attached to the helmet, in accordance with 7.2.

##### 5.2.2 Electrical insulation

When tested by the method given in 6.8 the leakage current shall not exceed 1,2 mA.

This requirement is intended to ensure protection from voltages of up to 440 V. Helmets claimed to meet this requirement shall state this fact on the label attached to the helmet, in accordance with 7.2.

##### 5.2.3 Lateral rigidity

When tested by the method given in 6.9 the maximum lateral deformation of the helmet shall not exceed 40 mm, and the residual deformation shall not exceed 15 mm.

Helmets claimed to meet this requirement shall state this fact on the label attached to the helmet, in accordance with 7.2.

### 6 TEST REQUIREMENTS

#### 6.1 Samples

Helmets shall be submitted for testing in the condition in which they are offered for sale, including any requisite holes in the shell, and other means of attachment of any accessories for special purposes.

No helmet that has been subjected to testing shall be offered for sale. The minimum number of samples required for one set of tests is as follows :

##### Mandatory tests

1 helmet for shock absorption test at  $-10\text{ }^{\circ}\text{C}$  (or at  $-20\text{ }^{\circ}\text{C}$ );

1 helmet for shock absorption test in moist conditions;

1 helmet for shock absorption test at  $+50\text{ }^{\circ}\text{C}$ , then for flammability test;

1 helmet for resistance to penetration test.

##### Optional tests

1 helmet for electrical insulation test;

1 helmet for lateral rigidity test;

1 helmet for the test for resistance to penetration at low temperature.

#### 6.2 Conditioning for testing

##### 6.2.1 Conditioning cabinet

This shall be sufficiently large to ensure that the helmets can be positioned so that they do not touch one another or the sides. It shall be fitted with a fan to provide effective air circulation.

##### 6.2.2 Pre-conditioning

All helmets shall be pre-conditioned for at least 7 days at a temperature of  $20\pm 2\text{ }^{\circ}\text{C}$  and a relative humidity of  $65\pm 5\%$  before applying the following individual conditioning treatments.

##### 6.2.3 Low temperature

The helmet shall be exposed to a temperature of  $-10\pm 2\text{ }^{\circ}\text{C}$  for not less than 4 h. When especially required (see 5.2.1) the temperature shall be reduced to  $-20\pm 2\text{ }^{\circ}\text{C}$ .

### 6.2.4 High temperature

The helmet shall be exposed to a temperature of  $50 \pm 2$  °C for a period of not less than 4 h.

### 6.2.5 Moisture

The helmet shall be sprayed externally with water at  $20 \pm 2$  °C at the rate of 1 l/min for not less than 4 h.

## 6.3 Headforms

### 6.3.1 Construction

Headforms used in the tests shall be either hardwood or metal.

The profile above the reference line shall be as defined in figures 1 and 2 and the table. The profile below the reference line may be varied to suit the method of mounting.

NOTE – These correspond to headforms D, G and K of ISO/R 1511.

A recommended method of constructing wooden headforms is given in annex A.

### 6.3.2 Selection of size

Helmets with adjustable harnesses shall be tested on the appropriate headform as selected by adjusting the harness to the middle size of the adjustment range.

Helmets with non-adjustable harnesses shall be tested on the appropriate size of headform.

## 6.4 Verification of clearances and wearing height

Vertical and horizontal clearance, and wearing height shall be measured with the helmet mounted in the wearing position on the appropriate headform. For helmets with adjustable harnesses, measurements shall be made on both the largest and smallest size of headform appropriate to its adjustment range.

## 6.5 Shock absorption test

### 6.5.1 Principle

Shock absorption is measured by the direct measurement of the maximum force transmitted to a rigidly mounted helmeted headform, or by the measurement of the maximum deceleration of the striker.

### 6.5.2 Apparatus

The base of the apparatus shall be monolithic and sufficiently large to offer full resistance to the effect of the blow. It shall have a mass of at least 500 kg and shall be suitably installed to obviate the return compression wave.

The headform shall be rigidly mounted in a vertical position on the base.

A striker, having a mass of  $5,0 + 0,1$  kg and a hemispherical striking face of 48 mm radius, shall be positioned above the headform so that its axis coincides with the vertical axis of the headform and so that it may be dropped in guided fall with a minimum retardation from the guides.

The impact force shall be measured by a non-inertial force transducer firmly attached to the base, or by an accelerometer firmly attached to the striker. It shall be so positioned that its axis is co-axial with the path of the striker.

The system of measurement used shall be able to measure without distortion forces of up to 40 kN and shall have a flat frequency response within  $\pm 5\%$  between 5 and 1 000 Hz. It should be noted that, where a force transducer is used in conjunction with the headform, the headform and its mount form part of the measuring system; where an accelerometer is used in the striker, the striker forms part of the measuring system.

### 6.5.3 Test procedure

Each of the requisite sample helmets specified in 6.1 shall be conditioned appropriately in accordance with 6.2. Within 1 min of its removal from the conditioning atmosphere it shall be placed firmly, and fastened securely, on the appropriate headform (see 6.3) at its greatest possible wearing height and with a total clearance of approximately 10 mm between the headband and the headform measured by the insertion of a 10 mm diameter rod. The striker shall be allowed to fall on the centre of the crown of the helmet shell with an impact energy of 50 J attained by the striker falling from a height of  $1\,000 \pm 5$  mm. The height of the fall shall be measured from the point of impact on the helmet shell to the underside of the striker.

A recording shall be made allowing the determination of the maximum force of impact.

## 6.6 Penetration test

### 6.6.1 Apparatus

A test striker is allowed to fall freely onto a helmet securely fastened to a suitable headform. The contactable surface of the headform shall be of a metal that will readily permit detection should contact by the striker occur, and that can be restored after contact, if necessary.

The striker has the following characteristics :

Mass :  $3,0 + 0,05$  kg

Angle of point : 60°

Radius of point : 0,5 mm

Minimum height of cone : 40 mm

Hardness of tip : between 50 and 45 Rockwell hardness

**6.6.2 Test procedure**

The helmet shall be conditioned in the manner that gave the worst result in the shock absorption tests. Within 1 min of its removal from the conditioning atmosphere it shall be placed firmly, and fastened securely, on the appropriate headform (6.3) at its greatest possible wearing height and with a total clearance of approximately 10 mm between the headband and the headform, measured by the insertion of a 10 mm diameter rod.

The striker shall be allowed to fall on to the top of the helmet, within a circular area of 100 mm diameter, through a distance of  $1\ 000 \pm 5$  mm measured from the top of the helmet to the point of the striker. The striker may fall freely or may be guided but the speed of impact of a guided striker shall equal that of a free fall.

Note is taken of whether or not contact is made between the striker and the headform. Contact may be verified electrically but a physical check shall be made on the contact surface. If necessary the surface shall be restored prior to a subsequent test.

**6.7 Flammability test**

The test shall be carried out on the helmet used for the shock absorption test at 50 °C.

**6.7.1 Apparatus**

The burner shall be a Bunsen burner suitable for propane gas, with a 10 mm diameter bore, an adjustable air vent and an appropriate size of jet; the system shall incorporate a pressure control device and a tap.

The gas used shall be propane having a minimum purity of 95 %.

**6.7.2 Test procedure**

The gas pressure shall be adjusted to 3 430 Pa (350 mmH<sub>2</sub>O), as measured by a suitable manometer.

The flame shall be adjusted by means of the air vent so that the blue cone is clearly defined, although turbulent, and is approximately 15 mm long.

With the helmet upside down, and the burner angled at 45° to the vertical, the end of the flame shall be applied to the outside of the shell, at any suitable point between 50 and 100 mm from the crown, for a period of 10 s. The plane tangential to the test point shall be horizontal.

The shell shall be examined for flaming 5 s after removal of the flame.

**6.8 Electrical insulation test**

The complete helmet shall be placed for 24 h before testing in a 3 g/l solution of sodium chloride at a temperature between 10 and 30 °C. The helmet shall then be removed, wiped, and placed upside down in a container

of appropriate size. The container and the helmet shall then be filled with the sodium chloride solution, up to 30 mm below the plane in which the brim is connected to the shell.

A voltage, linearly and gradually increasing within 1 min to 1 200 V at 50 to 60 Hz, shall be applied between an electrode immersed in the solution inside the helmet and the other electrode in the container. The maximum voltage shall be maintained for 1 min and the leakage current measured.

**6.9 Lateral rigidity test**

The helmet shall be tested transversely (ear to ear) between two guided parallel plates having their lower edges radiused to 10 mm.

The helmet shall be pre-conditioned in accordance with 6.2.2, and then placed between the plates so that the brim lies outside, but as close to the plates as possible. An initial force of 30 N shall be applied to the plates at right angles, so that the helmet is subjected to a lateral pressure. After 30 s the distance between the plates shall be measured.

The force shall be increased by 100 N per minute up to 430 N, which shall be held for 30 s, after which the distance between the plates (maximum lateral deformation) shall again be measured.

The force shall be decreased to 25 N and then immediately increased to 30 N, which shall be held for 30 s, after which the distance between the plates (residual deformation) shall again be measured. Measurements shall be made to the nearest millimetre, and the extent of damage, if any, shall be noted.

**7 MARKING**

**7.1 Markings on the helmet**

Every helmet claimed to comply with the requirements of this International Standard shall be visibly and durably marked with the following information :

- a) Number of this International Standard — ISO 3873.
- b) Country of origin.
- c) Name or identification mark of the manufacturer.
- d) Year and quarter of manufacture.
- e) Type of helmet (manufacturer's designation). This shall be marked on both the shell and the harness.

**7.2 Additional information**

A label shall be attached to each helmet stating the following in the language of the country of sale :

- a) "For adequate protection this helmet must fit or be adjusted to the size of the user's head.

This helmet is made to absorb the energy of a blow by partial destruction or damage to the shell and the harness, and even though such damage may not be readily apparent, any helmet subjected to severe impact should be replaced.

The attention of users is also drawn to the danger of modifying or removing any of the original component parts of the helmet."

b) The mass, if this exceeds 400 g. See 4.7.

c) The optional requirements complied with. These may be marked as :

"- 20 °C" for the low temperature requirement;

"RL" for the lateral rigidity requirement;

"440 V" for the electrical insulation requirement.

## iTeh STANDARD PREVIEW (standards.iteh.ai)

[ISO 3873:1977](https://standards.iteh.ai/catalog/standards/sist/5350c552-96fb-4022-a611-ec8e394b3cb4/iso-3873-1977)

<https://standards.iteh.ai/catalog/standards/sist/5350c552-96fb-4022-a611-ec8e394b3cb4/iso-3873-1977>

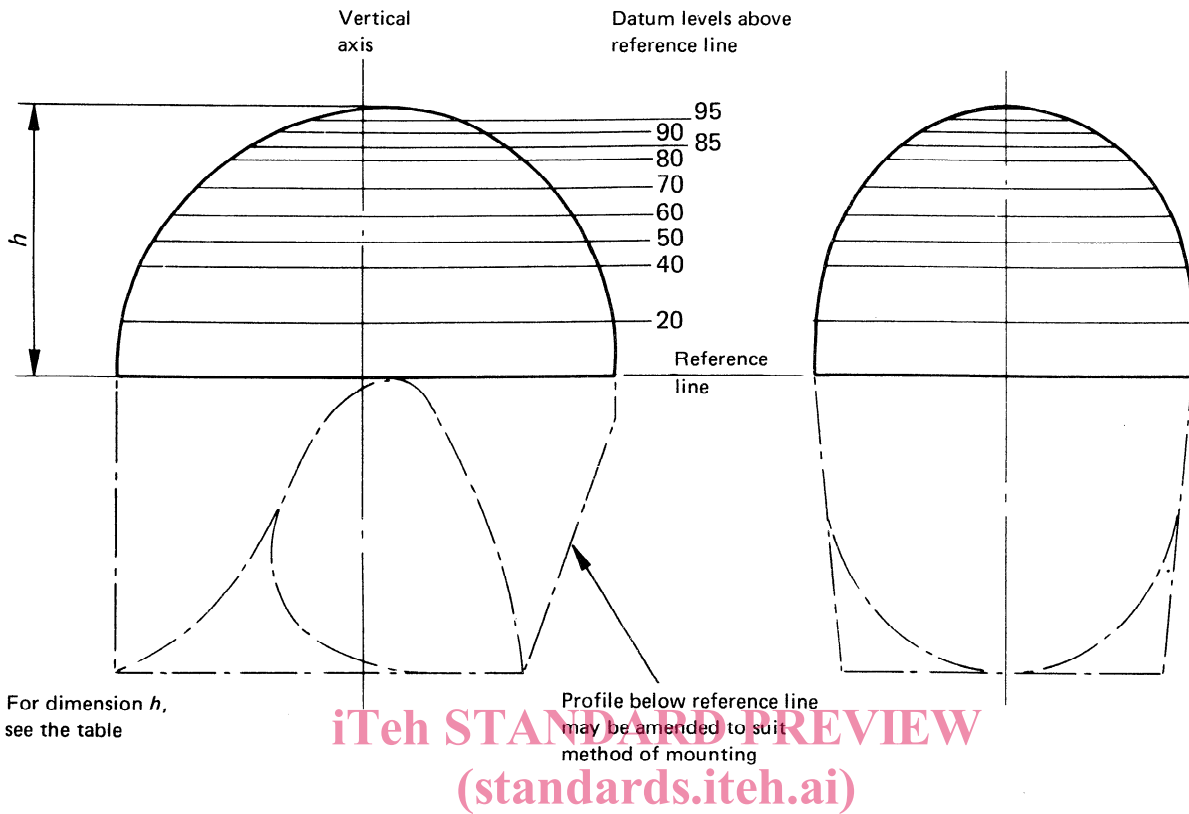

FIGURE 1 — Headform elevations  
<https://standards.iteh.ai/catalog/standards/sist/5350c552-96fb-4022-a611-ec8e394b3cb4/iso-3873-1977>

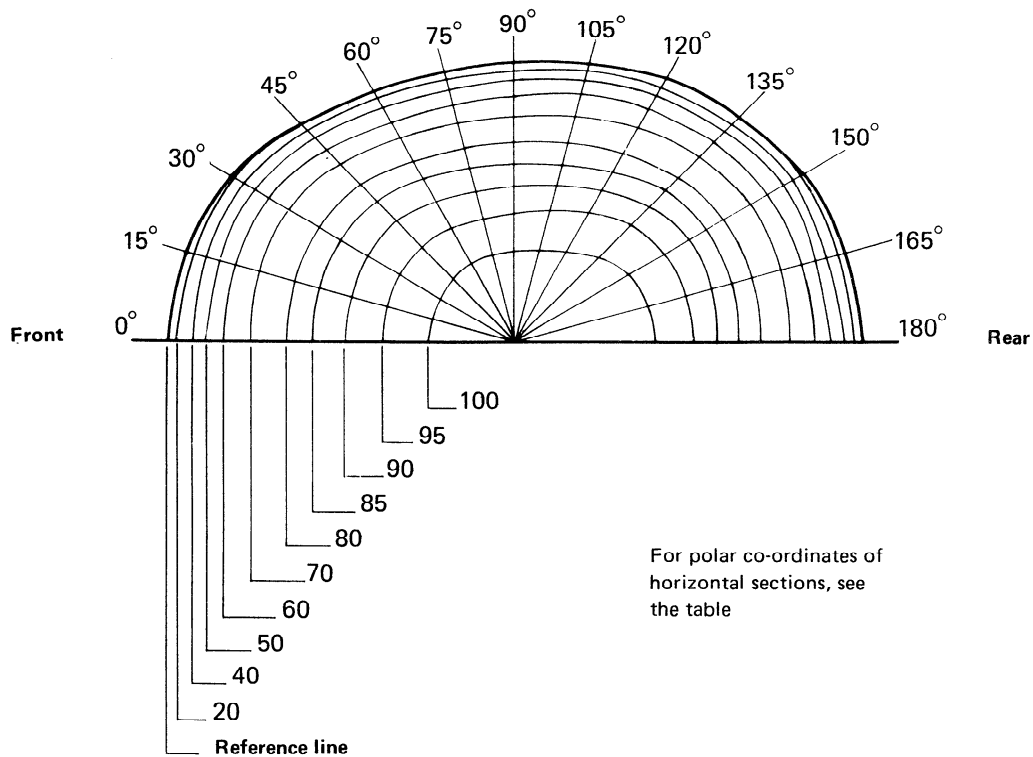

FIGURE 2 — Horizontal half-sections at datum levels



TABLE – Polar co-ordinates of horizontal half-sections of headforms lettered D, G and K

Dimensions in millimetres

**Headform D – Dimension  $h = 94,5$**

Datum level	0°	15°	30°	45°	60°	75°	90°	105°	120°	135°	150°	165°	180°
0	93	91	88	81	74,5	71,5	71	74	78	84	89,5	92	93
20	91	89,5	87	81	74,5	71,5	71	74	78	84	89,5	92	92,5
40	85	85	83,5	77,5	72	68,5	69	71	75	80,5	86	87	87,5
50	81	80,5	80	74	69	66	66	69	72	77,5	82,5	83	83,5
60	75	75	74	68	63,5	61	61	63,5	67,5	72	76	77	77,5
70	64,5	64,5	64,5	60	55,5	53	53,5	56	60	64,5	68	68,5	69
80	48,5	48,5	48,5	47	44,5	43	43	45	48,5	53,5	57,5	58	58
85	39	39	39	37	37	36	36	28	41	45,5	48,5	49	49
90	23	23	23	24	24,5	25	25	27	30	33	37	37	37

**Headform G – Dimension  $h = 99$**

Datum level	0°	15°	30°	45°	60°	75°	90°	105°	120°	135°	150°	165°	180°
0	97,5	95,5	93	85,5	79,5	76	76	78,5	83	88,5	94	97	97,5
20	95,5	94	92	85,5	79,5	76	76	78,5	83	88,5	94	96,5	97
40	90	89	88	83	77	74,5	74	76,5	81	86	91	92	92
50	86,5	86	85	79,5	74	71,5	71,5	73,5	78,5	83,5	87,5	88,5	88,5
60	80,5	80	79,5	74	70	66,5	66	68,5	73	78	82	82	82,5
70	71	71	71	67	62,5	60	59,5	61,5	66,5	71,5	74,5	75	75
80	57,5	57,5	57,5	55	52	50	50	53	57	62	65	65	65
85	48	48	48	47	45	44	44	46	50	55,5	59	59	59
90	37	37	37	36	36,5	36	36	38	42	48	50	51	51
95	21	21	21	22	23	24	24	26	29	34	38	39,5	39,5

**Headform K – Dimension  $h = 104$**

Datum level	0°	15°	30°	45°	60°	75°	90°	105°	120°	135°	150°	165°	180°
0	102,5	101	97	90	84	81,5	81	83,5	88	93	98,5	101,5	102,5
20	100,5	99	97	90	84	81,5	81	83,5	88	93	98,5	101	102
40	95	95,5	93	87	82	79	79	81,5	85	90	95	97	97,5
50	91,5	91	90	84,5	79	76,5	76,5	79	83	88	92,5	93	93,5
60	86	86	85	79,5	74,5	72	72,5	75	78,5	83	86,5	88	88,5
70	77,5	77,5	77,5	73	68,5	66	66	68,5	72	77	80	81,5	81,5
80	67	67	67	65,5	60,5	58	57,5	59,5	63	68	72	72,5	72,5
85	59,5	59,5	59,5	58	55	53	52	54	57	62,5	66	66,5	66,5
90	50	50	50	50	47	45,5	45,5	47,5	50,5	55,5	60	60	60
95	39	39	39	39	38	36,5	37,5	39	43	48	52	52,5	52,5
100	25	25	25	25,5	26	26	25	26,5	30	35	39	41	41