



Designation: **F2194 – 16 F2194 – 16^{ε1}**

Standard Consumer Safety Specification for Bassinets and Cradles¹

This standard is issued under the fixed designation F2194; the number immediately following the designation indicates the year of original adoption or, in the case of revision, the year of last revision. A number in parentheses indicates the year of last reappraisal. A superscript epsilon (ϵ) indicates an editorial change since the last revision or reappraisal.

^{ε1} NOTE—Editorially corrected 2.3 in June 2016.

INTRODUCTION

This consumer safety performance specification addresses infant bassinet and cradle incidents identified by the U.S. Consumer Product Safety Commission (CPSC).

In response to the incident data compiled by the CPSC, this consumer safety performance specification attempts to minimize the following hazards: (1) suffocation, (2) tip over, (3) collapse, and (4) hood detachment. It also addresses corner post extensions, which may catch pacifier cords, ribbons, necklaces, or clothing which a child may be wearing and which may be caught on a projection. This specification does not cover products that are blatantly misused or used in a careless manner that disregards the safety instructions and warnings provided with each bassinet or cradle.

1. Scope

1.1 This consumer safety specification covers performance requirements, test methods, and marking requirements to promote safe use of bassinets and cradles.

1.2 This consumer safety performance specification is intended to minimize the risks of incidents to an infant resulting from normal use and reasonably foreseeable misuse of a bassinet or cradle.

1.3 This consumer safety performance specification covers products primarily intended to provide sleeping accommodations for an infant up to approximately 5 months in age or when the child begins to push up on hands and knees, whichever comes first. Products used in conjunction with an inclined infant swing or stroller, or products that are intended to provide an inclined sleep surface (head-to-toe direction) of greater than 10° from horizontal while in the rest (non-rocking) position are not covered by this specification.

1.3.1 *Rationale*—The addition of developmental criteria was added to the 5-month age grade to accommodate varying motor skills in children.

NOTE 1—Cradle swings with an incline less than or equal to 10° from horizontal while in the rest (non-rocking) position are covered under the scope of this standard. A sleep product that only has inclined sleeping surfaces (intended to be greater than 10° from horizontal while in the rest (non-rocking) position) does not fall under the scope of this standard. If a product can be converted to a bassinet/cradle use mode and meets the definition of a bassinet/cradle found in 3.1.1 while in that mode, the product shall be included in the scope of this standard, when it is in the bassinet/cradle use mode. For example, strollers that have a carriage/bassinet feature are covered by the stroller/carriage standard when in the stroller use mode. Carriage baskets/bassinets that are removable from the stroller base are covered under the scope of this standard when the carriage basket/bassinet meets the definition of a bassinet/cradle found in 3.1.1. Bassinet/cradle attachments to cribs or play yards, as defined in 3.1.2 or 3.1.13, are included in the scope of the standard when in the bassinet/cradle use mode.

1.4 No bassinet or cradle produced after the approval date of this consumer safety performance specification shall, either by label or other means, indicate compliance with this specification unless it conforms to all requirements contained herein.

1.5 This consumer safety performance specification is not intended to address incidents and injuries resulting from alteration or unreasonable abuse or misuse of the product by a child or child care giver.

1.6 The values stated in inch-pound units are to be regarded as standard. The values given in parentheses are mathematical conversions to SI units that are provided for information only and are not considered standard.

¹ This specification is under the jurisdiction of ASTM Committee F15 on Consumer Products and is the direct responsibility of Subcommittee F15.18 on Cribs, Toddler Beds, Play Yards, Bassinets, Cradles and Changing Tables.

Current edition approved April 15, 2016. Published May 2016. Originally approved in 2002. Last previous edition approved in 2013 as F2194 – 13a. DOI: 10.1520/F2194-16-10.1520/F2194-16E01.

1.7 The following precautionary caveat pertains only to the test method portion Section 7 of this consumer safety performance specification. *This standard does not purport to address all of the safety concerns, if any, associated with its use. It is the responsibility of the user of this standard to establish appropriate safety and health practices and determine the applicability of regulatory requirements prior to use.*

2. Referenced Documents

2.1 ASTM Standards:²

D3359 Test Methods for Measuring Adhesion by Tape Test

F406 Consumer Safety Specification for Non-Full-Size Baby Cribs/Play Yards

F963 Consumer Safety Specification for Toy Safety

2.2 Federal Regulations:³

16 CFR 1220 Safety Standard for Non-Full-Size Baby Cribs

16 CFR 1303 Ban of Lead-Containing Paint and Certain Consumer Products Bearing Lead-Containing Paint

16 CFR 1500 Hazardous Substances Act Regulations Including Sections

16 CFR 1500.48 Technical Requirements for Determining a Sharp Point in Toys and Other Articles for Use by Children Under Eight Years of Age

16 CFR 1500.49 Technical Requirements for Determining a Sharp Metal or Glass Edge in Toys or Other Articles Intended for Use by Children Under Eight Years of Age

² For referenced ASTM standards, visit the ASTM website, www.astm.org, or contact ASTM Customer Service at service@astm.org. For *Annual Book of ASTM Standards* volume information, refer to the standard's Document Summary page on the ASTM website.

³ Available from U.S. Government Printing Office Superintendent of Documents, 732 N. Capitol St., NW, Mail Stop: SDE, Washington, DC 20401.



FIG. 1 CAMI Infant Dummy, Mark II 17.5 lb (7.9 kg)

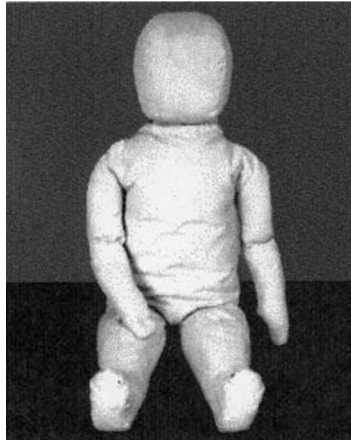

FIG. 12 CAMI Newborn Dummy 7.5 lb (3.4 kg)

16 CFR 1501 Method for Identifying Toys and Other Articles Intended for Use by Children Under Three Years of Age Which Present Choking, Aspiration, or Ingestion Hazards Because of Small Parts

2.3 Other References:

CAMI Dummy, MARK II (see Fig. 1)⁴

CAMI Newborn Dummy (See Fig. 12)⁵

3. Terminology

3.1 Definitions:

3.1.1 *bassinet/cradle, n*—small bed designed primarily to provide sleeping accommodations for infants, supported by free standing legs, a stationary base/stand, a wheeled base, a rocking base, or a base which can swing relative to a stationary base. While in a rest (non-rocking or swinging) position, a bassinet/cradle is intended to have a sleep surface less than or equal to 10° from horizontal.

3.1.1.1 *bassinet bed, n*—the sleeping area of the bassinet/cradle, containing the sleep surface and side walls.

3.1.1.2 *false latch/lock visual indicator, n*—a warning system using contrasting colors, lights, or other similar means designed to visually alert caregivers when a removable bassinet bed is not properly locked onto its base/stand.

3.1.1.3 *intended use orientation*—the bassinet bed orientation (that is, the position where the head and foot ends of the bassinet bed are located) with respect to the base/stand, as recommended by the manufacturer for intended use.

3.1.1.4 *removable bassinet bed, n*—a bassinet bed that is designed to separate from the base/stand without the use of tools. This definition does not include the play yard bassinet as defined in 3.1.13.

3.1.2 *bassinet/cradle accessory, n*—a supported sleep surface that attaches to a crib or play yard designed to convert the product into a bassinet/cradle intended to have a sleep surface less than or equal to 10° from horizontal while in a rest (non-rocking or swinging) position.

3.1.3 *conspicuous, adj*—describes a label that is visible, when the bassinet/cradle is in a manufacturer’s recommended use position, to a person standing near the bassinet/cradle at any one position around the bassinet/cradle but not necessarily visible from all other positions.

3.1.4 *double action release mechanism, n*—mechanism requiring either two consecutive actions, the first of which must be maintained while the second is carried out or two separate and independent single action locking mechanisms that must be activated simultaneously to fully release.

3.1.5 *fabric, n*—any woven, knit, coated, laminated, extruded, or calendared flexible material that is intended to be sewn, welded, heat sealed, or glued together as an assembly.

3.1.6 *manufacturer’s recommended use position, n*—any position that is presented as a normal, allowable, or acceptable configuration for the use of the product by the manufacturer in any descriptive or instructional literature. This specifically excludes positions that the manufacturer shows in a like manner in its literature to be unacceptable, unsafe, or not recommended.

⁴ Department of Transportation Memorandum Report AAC-119-74-14, Revision II, Drawing No. SA-1001 by Richard Chandler, July 2, 1974. Federal Aviation Administration, Civil Aeromedical Institute, Protection and Survival Laboratory, Aeromedical Center, Oklahoma City, OK 73125.

⁵ Drawing numbers 126-0000 through 126-0015 (sheets 1 through 3), 126-0017 through 126-0027, a parts list entitled “Parts List for CAMI Newborn Dummy,” and a construction manual entitled, “Construction of the Newborn Infant Dummy” (July 1992). Copies of the materials may be inspected at NHTSA’s Docket Section 400 Seventh Street, SW, Room 5109, Washington, DC, or at the Office of the Federal Register, 800 North Capitol Street, NW, Suite 700, Washington, DC.

3.1.7 *mattress support rods/bars*, *n*—component(s), typically rods or bars, that provide added support between the mattress support component and the mattress pad.

3.1.8 *maximum deflection angle*, *n*—the maximum rock/swing angle measurement allowed by the product design in the manufacturer's recommended use position in the manner normally associated with rocking/swinging as intended by the manufacturer.

3.1.9 *mesh*, *n*—mesh may be either a woven fabric in which the warp and filling yarns are interlaced, knitted fabric in which the wales and courses yarns are interlocked, or any other type of fabric that may be developed that provides openings therein.

3.1.10 *non-paper label*, *n*—any label material (such as plastic or metal) that either will not tear without the aid of tools or tears leaving a sharply defined edge.

3.1.11 *occupant*, *n*—that individual who is in a product that is set up in one of the manufacturer's recommended use positions.

3.1.12 *paper label*, *n*—any label material that tears without the aid of tools and leaves a fibrous edge.

3.1.13 *play yard bassinet*, *n*—bassinet accessory usually suspended in the upper portion of the play yard and typically has a folding or segmented mattress, or both.

3.1.14 *removable cover*, *n*—a fabric cover encompassing the recommended sleeping area for the occupant of the product, that uses snaps, zippers, hook and loop, buttons or other fasteners to attach to a bassinet/cribble frame that requires consumer action as a step for removal or adjustment.

3.1.15 *rest angle*, *n*—the resulting angle measurement of the bassinet/cribble sleeping surface after the maximum deflection angle is applied and released and the product has come to a complete rest.

3.1.16 *seam*, *n*—means for joining fabric components, such as sewing, welding, heat sealing, or gluing.

3.1.17 *static load*, *n*—vertically downward force applied by a calibrated force gauge or by dead weights.

4. Calibration and Standardization

4.1 All testing shall be conducted on a concrete floor that may be covered with 1/8-in. (3-mm) thick vinyl flooring cover, unless the test instructs differently.

4.2 The product shall be completely assembled, unless otherwise noted, in accordance with the manufacturer's instructions.

4.3 No testing shall be conducted within 48 h of manufacturing.

4.4 The product to be tested shall be in a room with ambient temperature of $73 \pm 9^\circ\text{F}$ ($23 \pm 5^\circ\text{C}$) for at least 1 h prior to testing. Testing then shall be conducted within this temperature range.

4.5 All testing required by this specification shall be conducted on the same unit.

4.6 Angle measurements shall be obtained using a digital inclinometer capable of 0.1° minimum resolution.

4.7 A force gauge with a minimum range of 0 to 25 lbf (110 N), accuracy of ± 0.25 lb.

5. General Requirements

5.1 *Lead in Paints*—The paint or surface coating on the product shall comply with 16 CFR 1303.

5.2 *Hazardous Sharp Edges or Points*—There shall be no hazardous sharp points or edges as defined by 16 CFR 1500.48 and 16 CFR 1500.49 before and after testing to this consumer safety specification.

5.3 *Small Parts*—There shall be no small parts as defined by 16 CFR 1501 before testing or liberated as a result of testing to this specification.

5.4 *Wood Parts*—Prior to testing, any exposed wood parts shall be smooth and free of splinters.

5.5 *Scissoring, Shearing, or Pinching*—A product, when in the manufacturer's recommended use position shall be designed and constructed so as to prevent injury to the occupant from scissoring, shearing, or pinching when members or components rotate about a common axis, or fastening points, slide, pivot, fold or otherwise move relative to one another. Scissoring, shearing, or pinching that may cause injury shall not be permissible when the edges of any rigid parts admit a probe that is greater than a 0.210-in. (5.33-mm) and less than a 0.375-in. (9.53-mm) diameter at any accessible point throughout the range of motion of such parts.

5.6 *Unintentional Folding*:

5.6.1 Products designed without latching or locking devices must remain in the manufacturer's recommended use position during and upon completion of the test, in accordance with 7.5.1.

5.6.2 Products designed with a single action release mechanism latching or locking devices must remain in the manufacturer's recommended use position during and upon completion of the test, in accordance with 7.5.2.

5.6.3 Products with a double action release mechanism latching or locking device shall require two distinct and separate actions for release of the mechanism.

5.7 *Openings*—Holes or slots that extend entirely through a wall section of any rigid material less than 0.375-in. (9.53-mm) thick and admit a 0.210-in. (5.33-mm) diameter rod shall also admit a 0.375-in. (9.53-mm) diameter rod. Holes or slots that are between 0.210-in. (5.33-mm) and 0.375-in. (9.53-mm) and have a wall thickness less than 0.375 in. (9.53 mm) but are limited in depth to 0.375-in. (9.53-mm) maximum by another rigid surface shall be permissible (see Fig. 23). The product shall be evaluated in all manufacturer’s recommended use positions.

5.8 *Labeling:*

5.8.1 Warning labels (whether paper or non-paper) shall be permanent when tested in accordance with 7.2.1 – 7.2.3.

5.8.2 Warning statements applied directly onto the surface of the product by hot stamping, heat transfer, printing, wood burning, etc. shall be permanent when tested in accordance with 7.2.4.1 – 7.2.4.3.

5.8.3 Non-paper labels shall not liberate small parts when tested in accordance with 7.2.5.

5.9 *Fasteners*—Woodscrews shall not be used in the assembly of any components that must be removed by the consumer in the normal disassembly of a bassinet/crible.

5.10 *Corner Posts:*

5.10.1 No corner post assembly shall extend more than 0.06 in. (1.5 mm) above the upper edge of an end or side panel, whichever is higher, when measured from the lowest point on the upper edge of the end panel within 3 in. (76 mm) from the outermost contour of the elbow (see Fig. 34).

5.10.2 The limitations in 5.10.1 do not apply to a corner post assembly that extends at least 16 in. (406 mm) above the uppermost surface of the side rail in its highest position.

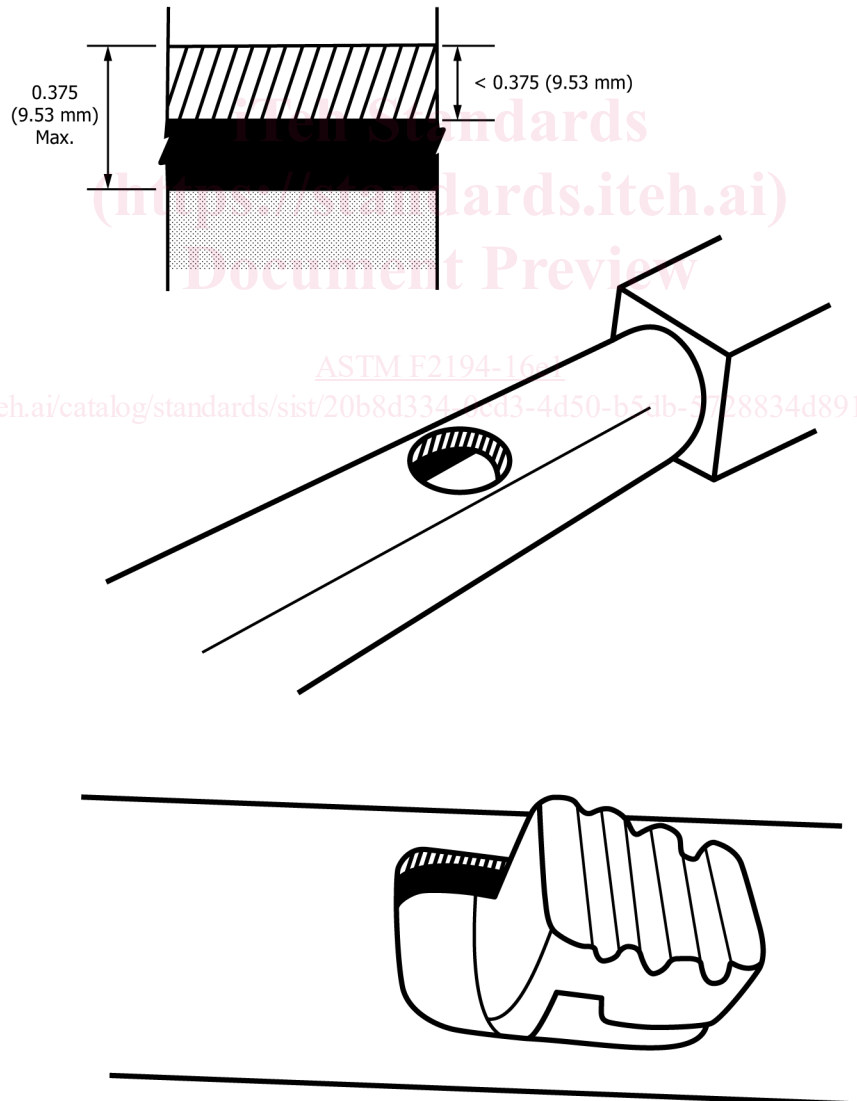

FIG. 23 Opening Example

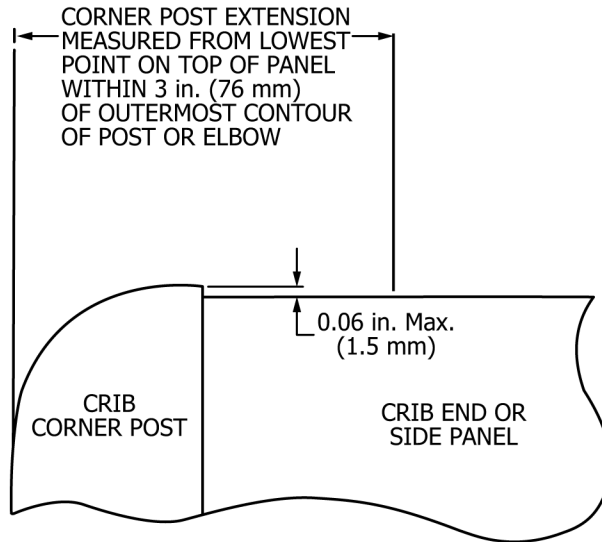

FIG. 34 Corner Post Extension

5.10.2.1 Corner posts intended to accept removable vertical extensions made up of two or more segments (such as canopy post extensions) shall not permit the attachment of individual segments such that the resultant vertical extension would be in violation of the dimensional requirements of 5.10.2.

5.11 Toys—Toy accessories attached to, removable from, or sold with a bassinet or cradle, as well as their means of attachment, must meet the applicable requirements of Consumer Safety Specification F963.

5.11.1 Toy mobiles that attach solely to a bassinet or cradle are not required to contain labeling as stated in Consumer Safety Specification F963, Section 5.6.2 (Safety Labeling Mobiles).

5.12 Bassinet/Cradle Accessory to Play Yard/Non-Full-Sized Crib—A bassinet accessory intended to be attached to, removable from, sold with or separately from a play yard or non-full-sized crib shall comply with the requirements of this specification and Consumer Safety Specification F406 when attached in the manufacturer’s recommended use position.

5.13 Occupant Restraint System—No product shall contain a restraint system in the occupant area when used in the bassinet/cradle mode.

6. Performance Requirements

6.1 Spacing of Rigid Sided Bassinet/Cradle Components—Spacing must comply with the applicable sections of 16 CFR 1220 when tested according to 7.1.

6.2 Openings for Mesh/Fabric Sided Bassinet/Cradle—Openings in the mesh shall be designed to prevent entrapment of fingers, toes, and snaring of buttons normally used on infant clothing. A mesh opening shall not fully accept the specified rod when tested in accordance with 7.6.

6.3 Static Load—A product shall support the static load without causing any hazardous conditions as identified within Section 5 of this consumer safety specification. This test shall be conducted in accordance with 7.3.

6.4 Stability—A product in all manufacturer’s recommended use positions, including positions where the locks are engaged for preventing rocking/swinging motion of the sleeping surface, shall not tip over and shall retain the CAMI dummy when subjected to the test described in 7.4.

6.5 Sleeping Pad:

6.5.1 Each product shall be sold with the sleeping pad included.

6.5.2 Pad Thickness for Fabric or Mesh Sided Products—The filling material of the uncompressed sleeping pad such as foam, fiberfill, etc. shall not exceed 1-in. (25-mm) in thickness. The total thickness of the uncompressed pad including all fabric or vinyl layers, filling material, and any structural members such as wood, hardboard, etc., shall not exceed 1½ in. (38 mm).

6.5.3 Pad Dimensions—The dimensions of the sleeping pad supplied with the product shall be such that the pad, when inserted in the center of the unit in a noncompressed state at any of the adjustable positions, shall not leave a gap of more than ½ in. (13 mm) at any point between the perimeter of the pad and the perimeter of the unit. When the pad is placed against the perimeter of the unit, the resulting gap shall not exceed 1 in. (25 mm).

6.5.4 Side Height—The upper surface of the non-compressed mattress of a bassinet/cradle, when the mattress support is in any position, must be at least 7.5 in. (191 mm) lower than the upper surface of the lowest side in all intended bassinet/cradle use positions as measured in accordance with 7.11.

6.6 *Protective Components*—If the occupant can grasp components between the thumb and forefinger or teeth (such as caps, sleeves, or plugs used for protection from sharp edges, points, or entrapment of fingers or toes), or if there is at least a 0.040-in. (1.00-mm) gap between the component and its adjacent parent component, such component shall not be removed when tested in accordance with 7.7.

6.7 *Bassinets with Segmented Mattresses: Flatness Test*—If the bassinet or bassinet accessory has a folding or segmented mattress, or both, any angle when measured in 7.8 less than or equal to 10° is an immediate pass. Any angle when measured in 7.8 greater than 10° is an immediate failure. Segmented bassinet mattresses that have seams (located between segments or where the mattress folds) that are less than 15 in. in length are excluded from this requirement.

6.7.1 *Rationale*—This test was created to address a suffocation hazard associated with “V” shapes formed in segmented mattresses seams and based on assessment of both newborn and infant anthropometric weights. The requirement was based on the 5th percentile newborn angle of 11°, on either side of a child’s nose, and subtracting 1° as a safety factor resulting in a maximum of 10°. The infant cylinder was selected for this test as it captured all failures encountered with a newborn cylinder but also captured failures undetected by the newborn cylinder. The infant test cylinder is a more stringent test given the allowable angle of a newborn is 10° maximum instead of the infant 14°.

6.8 *Fabric Sided Enclosed Openings*—For bassinets/cradles with fabric sides, a completely bounded opening shall not be created that allows the complete passage of the torso probe (Fig. 45) when tested in accordance with 7.9. This test does not apply to play yard bassinets as defined in 3.1.13 or bassinet/cradle accessories as defined in 3.1.2.

6.9 *Rock/Swing Angle*—Bassinets or cradles that incorporate a rock/swing feature shall meet the following:

6.9.1 The maximum deflection angle measurement on any reading shall not exceed 20° when tested in accordance with 7.10.

6.9.2 The arithmetic mean of the rest angle measurements shall not exceed 7° when calculated for each rock/swing direction independently, when tested in accordance with 7.10.

6.10 *Removable Bassinet Bed Attachment to Base/Stand*—Any product containing a removable bassinet bed with a latching or locking device intended to secure the removable bassinet bed to the base/stand shall comply with at least one of the following 6.10.1 – 6.10.5 when tested in accordance with 7.12.

6.10.1 The base/stand shall not support the removable bassinet bed (that is, the removable bassinet bed falls from the base/stand and contacts the floor or the base/stand collapses when the removable bassinet bed is not locked into the base/stand).

6.10.2 The lock/latch shall automatically engage under the weight of the removable bassinet bed (without any other force or action) in all lateral positions, as shown in Fig. 56.

6.10.3 The sleep surface of the removable bassinet bed shall be at an angle of at least 20° from a horizontal plane when the removable bassinet bed is in an unlocked position.

6.10.4 The removable bassinet bed or base stand, or both, shall provide a false latch/lock visual indicator(s) that are at a minimum visible from both of the long sides of the product. A visual indicator(s) shall be visible to a person standing at each of the long sides of the product but not necessarily visible from all other positions around the product.

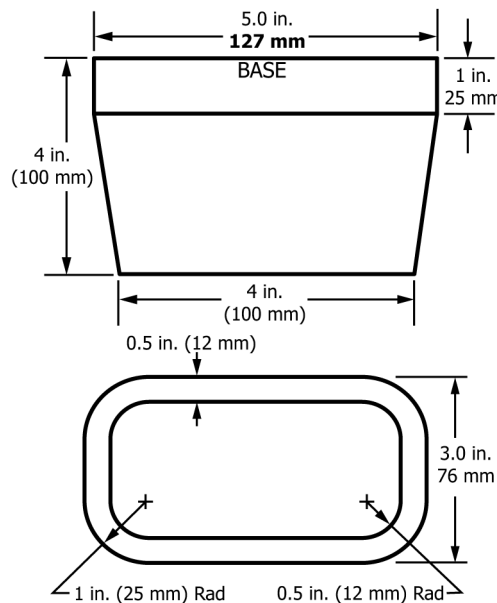

Material: Any rigid Material

NOTE 1—The probe dimensions represent the torso diameter of a 5th percentile 0 to 2-month-old infant.

FIG. 45 Torso Probe

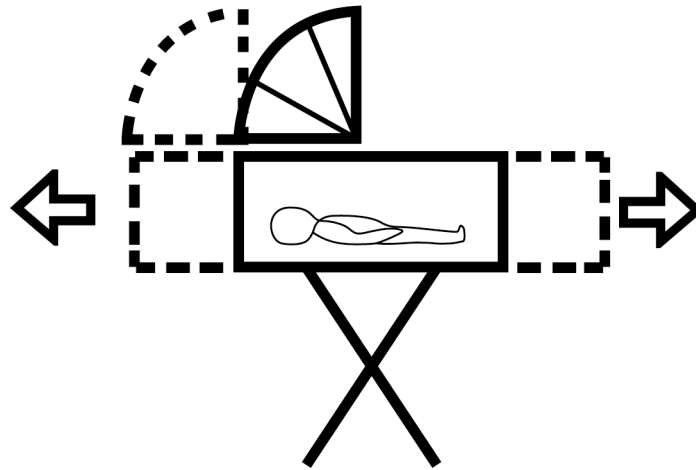

FIG. 56 Bassinet Bed Resting on Stand, Showing Possible Alternate Lateral Positions

6.10.5 The removable bassinet bed shall not tip over and shall retain the CAMI newborn dummy when tested in accordance with 7.12.5.3.

7. Test Methods

7.1 *Component Spacing*—For compliance with the spacing of components test requirement and procedures, the sections related to “Spacing of Unit Components” of the referenced Consumer Safety Specification F406 in 16 CFR 1220 shall be used.

7.2 *Permanency of Labels and Warnings:*

7.2.1 A paper label (excluding labels attached by a seam) shall be considered permanent if, during an attempt to remove it without the aid of tools or solvents, it cannot be removed, it tears upon removal, or such action damages the surface to which it is attached.

7.2.2 A non-paper label (excluding labels attached by a seam) shall be considered permanent if, during an attempt to remove it without the aid of tools or solvents, it cannot be removed or such action damages the surface to which it is attached.

7.2.3 A warning label attached by a seam shall be considered permanent if it does not detach when subjected to a 15-lbf (67-N) pull force applied in any direction most likely to cause failure using a clamp with a 3/4-in. (19-mm) diameter clamping surface. Apply the force evenly over 5 s and maintain for an additional 10 s.

7.2.4 *Adhesion Test for Warnings Applied Directly onto the Surface of the Product:*

7.2.4.1 Apply the tape test defined in Test Method B, Cross-Cut Tape Test of Test Methods D3359, eliminating the parallel cuts.

7.2.4.2 Perform this test once in each different location where warnings are applied.

7.2.4.3 The warning statements will be considered permanent if the printing in the area tested is still legible and attached after being subjected to this test.

7.2.5 A non-paper label, during an attempt to remove it without the aid of tools or solvents, shall not be removed or shall not fit entirely within the small parts cylinder defined in 16 CFR 1501 if it can be removed.

7.3 *Static Load:*

7.3.1 Assemble bassinet/cradle per manufacturer’s instructions.

7.3.2 Place a 6 by 6 by 3/8-in. (152 by 152 by 9.5-mm) nominal thickness aluminum block in the bassinet/cradle at the center of the sleeping pad. Gradually apply a weight of 54 lb (24 kg) or 3 times the manufacturer’s recommended weight (whichever is greater) within 5 s on the block and maintain for 60 s.

7.3.3 Test the unit in all manufacturer’s recommended use positions that could affect the sleeping surface’s ability to withstand the test weight.

7.3.4 For play yards bassinet, repeat 7.3.2 and 7.3.3, except apply the 54 lb weight or 3 times the manufacturer’s recommended weight (whichever is greater) at a corner of the bassinet portion in the play yard.

7.3.5 Repeat 7.3.4 at each of the other three corners.

7.3.5.1 *Rationale*—54 lb is 3 times the weight of the 95 percentile of a 3- to 5-month-old infant.

7.4 *Stability:*

7.4.1 Assemble bassinet/cradle in accordance with manufacturer’s instructions.

7.4.2 Establish a horizontal test plane with a piece of 1 in. (25.4 mm) high by 1 in. (25.4 mm) wide aluminum angle stop whose length is at least 6 in. (152 mm) longer than the length of the unit being tested as shown in (a), (b), and (c) of Fig. 67. For units with a rocking base as shown in (b) of Fig. 67, the height or position of the angle stop must be such that no part of the unit’s arched base will move on top of the angle stop when tilted.

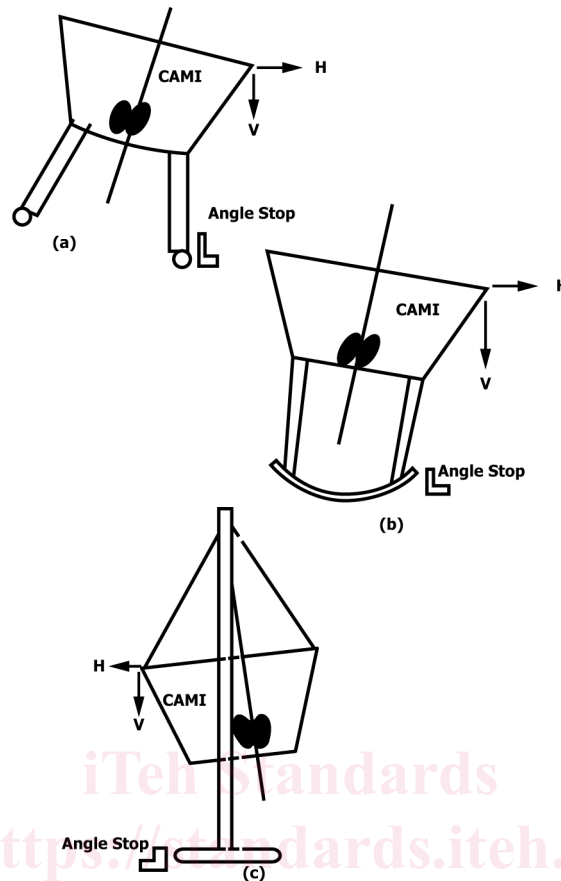

FIG. 67 Angle Stop

7.4.3 Position the unit on the floor and place against the angle stop.

7.4.4 Place the CAMI Newborn Dummy on the sleeping pad in the center of the product face up with the arms and legs straightened.

7.4.5 Apply a 23-lb (10.35-kg) static vertical load to the most onerous position along the upper side rail closer to the angle stop. Apply the static load over a 5 s period and maintain the static load during the application of the force specified in 7.4.6.

7.4.6 Gradually apply a horizontal force of 5 lb (22 N) within 5 s at the same location of the uppermost horizontal side rail where the vertical load is applied. The direction of the load is such that the unit is forced against the stop.

7.4.6.1 *Rationale*—The dual application of the horizontal and vertical forces will simulate an angled load tipping the unit over. The 23-lb load is the mean strength of a male 2-year-old pulling.⁶

7.4.7 Maintain the application of the static vertical load and horizontal force for 10 s.

7.4.8 Test the unit in all manufacturer's recommended use positions.

7.5 Unintentional Folding Test:

7.5.1 Products Designed Without Latching or Locking Devices:

7.5.1.1 Place the unit in the manufacturer's recommended use position.

7.5.1.2 Place a CAMI Infant Dummy, Mark II, in the center of the product face up with the arms and legs straightened.

7.5.1.3 Place a stop on the floor in a manner that would prevent the unit from sliding and tipping but will not prevent it from folding.

7.5.1.4 Position the unit against the stop in the orientation most likely to cause it to fold. Apply a 20-lbf (89-N) in direction most likely to fail to the top edge of the bassinet.

7.5.2 *Products designed with a single action release mechanism latching or locking devices*—With the product in the manufacturer's recommended use position, gradually apply a force of 10 lb (45 N) to the latching or locking mechanism in the direction tending to release it.

7.6 Mesh Opening Test:

⁶ Brown, W. C., Buchanan, C. J., and Mandel, J., A Study of the Strength Capabilities of Children Ages Two Through Six, Report No. NBSIR 73-156, U.S. Department of Commerce, Bureau of Standards, Washington, D.C., 1973.

7.6.1 *Equipment*—A steel rod of 0.250 in. (6.35 mm) in diameter with a 0.125-in. (3.18-mm) full radius tip.

7.6.2 *Procedure*—With the product in the fully erect position, gradually apply a force of 5 lb (22 N) perpendicular to the plane of the mesh opening using the rod specified above.

7.7 *Removal of Protective Components:*

7.7.1 Any protective component shall be tested in accordance with each of the following test methods in the sequence listed.

7.7.2 Secure the product so that it cannot move during the performance of the following test methods:

7.7.3 *Torque Test*—A torque of 2 lb-in. (0.23 N·m) shall be applied evenly within a period of 5 s in a clockwise direction until a rotation of 180° from the original position has been attained or 2 lb-in. (0.23 N·m) has been reached. The torque or maximum rotation shall be maintained for an additional 10 s. The torque shall be removed and the protective components permitted to return to a relaxed condition. The procedure shall be repeated in the counterclockwise direction.

7.7.4 *Tension Test:*

7.7.4.1 Attach a force gauge to the cap, sleeve, or plug by means of any suitable device. For protective components that cannot reasonably be expected to be grasped between thumb and forefinger or teeth on their outer diameter but have a gap of at least 0.040 in. (1.0 mm) between the rear surface of the component and the structural member of the bassinet/cradle to which it is attached, a clamp such as that shown in Fig. 78 may be a suitable device.

7.7.4.2 Be sure that the attachment device does not compress or expand the component hindering any possible removal.

7.7.4.3 Gradually apply 15 lbf (67 N) in the direction that would normally be associated with the removal of the protective component over a 5-s period and hold for an additional 10 s.

7.8 *Segmented Mattress Flatness Test:*

7.8.1 *Angle Measurement for Bassinets Intended For a Single Occupant:*

7.8.1.1 Establish a horizontal reference plane by placing an inclinometer, with an accuracy capable of 0.5° minimum resolution, on the floor of the testing area and zeroing it.

7.8.1.2 Assemble the product according to the manufacturer’s instructions. If the product has more than one mode, assemble in the bassinet mode(s). Disable the rocking/swinging feature if the product is equipped with such a feature.

iteh Standards
(http://www.iteh.ai)
Document Preview

15 lbf (67 N) MAX TENSION

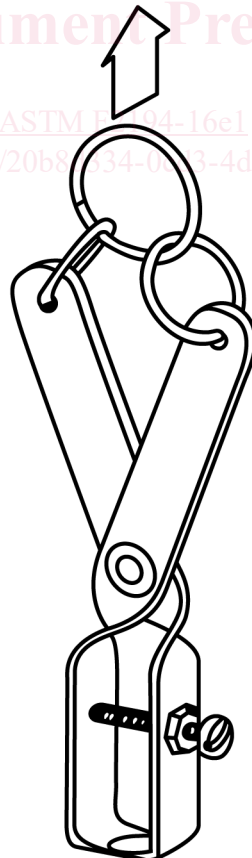

FIG. 78 Sketch of Clamping Device