



## Designation: **G133–05 (Reapproved 2010) G133 – 05 (Reapproved 2016)**

# Standard Test Method for Linearly Reciprocating Ball-on-Flat Sliding Wear<sup>1</sup>

This standard is issued under the fixed designation G133; the number immediately following the designation indicates the year of original adoption or, in the case of revision, the year of last revision. A number in parentheses indicates the year of last reapproval. A superscript epsilon ( $\epsilon$ ) indicates an editorial change since the last revision or reapproval.

## 1. Scope

1.1 This test method covers laboratory procedures for determining the sliding wear of ceramics, metals, and other candidate wear-resistant materials using a linear, reciprocating ball-on-flat plane geometry. The direction of the relative motion between sliding surfaces reverses in a periodic fashion such that the sliding occurs back and forth and in a straight line. The principal quantities of interest are the wear volumes of the contacting ball and flat specimen materials; however, the coefficient of kinetic friction may also be measured using the method described. This test method encompasses both unlubricated and lubricated testing procedures. The scope of this test method does not include testing in corrosive or chemically aggressive environments.

1.2 The values stated in SI units are to be regarded as the standard. The values given in parentheses are for information only.

1.3 *This standard does not purport to address all of the safety concerns, if any, associated with its use. It is the responsibility of the user of this standard to establish appropriate safety and health practices and determine the applicability of regulatory limitations prior to use.*

## 2. Referenced Documents

2.1 *ASTM Standards:*<sup>2</sup>

[E112 Test Methods for Determining Average Grain Size](#)

[E1181 Test Methods for Characterizing Duplex Grain Sizes](#)

[G40 Terminology Relating to Wear and Erosion](#)

[G99 Test Method for Wear Testing with a Pin-on-Disk Apparatus](#)

[G115 Guide for Measuring and Reporting Friction Coefficients](#)

[G117 Guide for Calculating and Reporting Measures of Precision Using Data from Interlaboratory Wear or Erosion Tests](#)

[G118 Guide for Recommended Format of Wear Test Data Suitable for Databases](#)

## 3. Terminology

3.1 *Definitions:*

3.1.1 Definitions used in this test method are given in Terminology [G40](#). The following definitions of important terms used in this test method are cited from Terminology [G40](#).

3.1.2 *friction force*—the resisting force tangential to the interface between two bodies when, under the action of an external force, one body moves or tends to move relative to the other.

3.1.3 *Hertzian contact pressure*—the magnitude of the pressure at any specified location in a Hertzian contact area, as calculated from Hertz's equations of elastic deformation.

3.1.4 *wear*—damage to a solid surface, generally involving the progressive loss of material due to relative motion between that surface and a contacting surface or surfaces.

3.1.5 *wear rate*—the rate of material removal or dimensional change due to wear per unit of exposure parameter, for example, quantity removed (mass, volume, thickness) in unit distance of sliding or unit time.

## 4. Summary of Test Method

4.1 This test method involves two specimens—a flat specimen and a spherically ended specimen (herein called the “ball” specimen) which slides against the flat specimen. These specimens move relative to one another in a linear, back and forth sliding motion, under a prescribed set of conditions.

<sup>1</sup> This test method is under the jurisdiction of ASTM Committee [G02](#) on Wear and Erosion and is the direct responsibility of Subcommittee [G02.40](#) on Non-Abrasive Wear. Current edition approved April 1, 2010; June 1, 2016. Published April 2010; June 2016. Originally approved in 1995. Last previous edition approved in 2005 as [G133G133 – 05 \(2010\)](#). DOI: [10.1520/G0133-05R10](#); [10.1520/G0133-05R16](#).

<sup>2</sup> For referenced ASTM standards, visit the ASTM website, [www.astm.org](#), or contact ASTM Customer Service at [service@astm.org](#). For *Annual Book of ASTM Standards* volume information, refer to the standard's Document Summary page on the ASTM website.

4.2 In this test method, the load is applied vertically downward through the ball specimen against the horizontally mounted flat specimen. The normal load, stroke length, frequency and type of oscillation, test temperature, lubricant (if any), test duration, and atmospheric environment (including relative humidity range) are selected from one of two procedures.

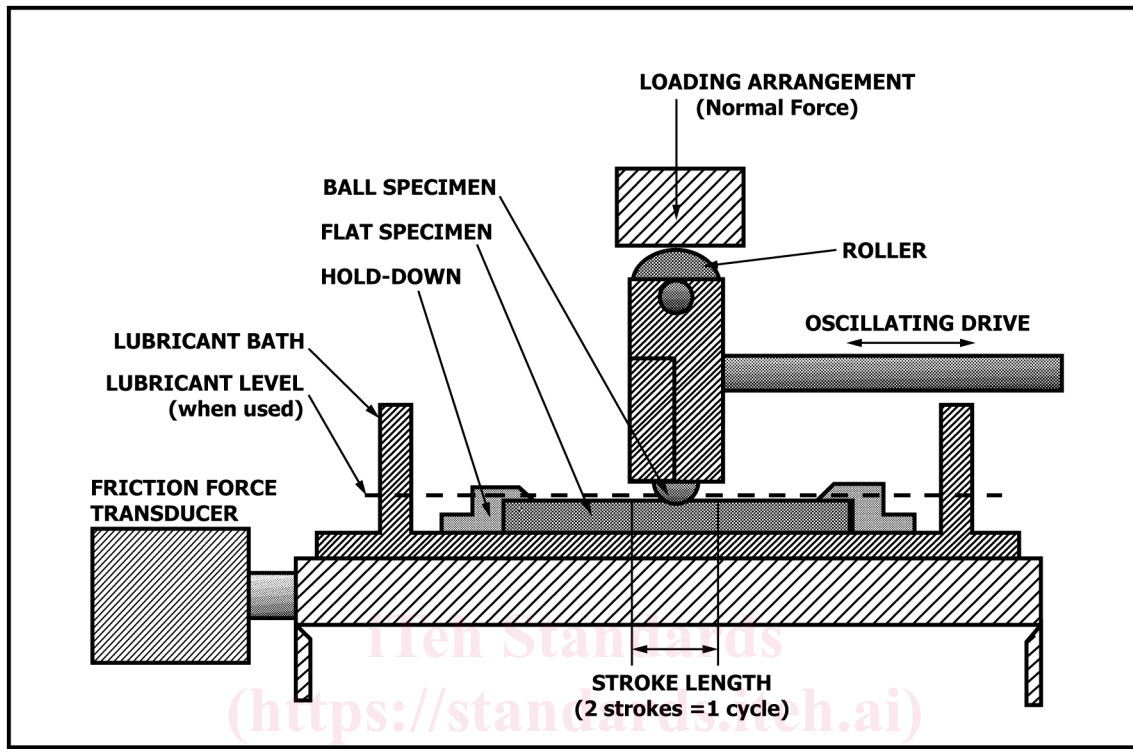

FIG. 1 Reciprocating Test—Schematic Diagram

4.3 Since this test method involves reciprocating sliding where changes in the sliding velocity and direction of motion occur during the test, constant velocity conditions are not maintained. The manner in which the velocity varies with time is determined by the design of the mechanism which drives the ball or flat specimen back and forth.

4.4 Dimensional changes for both ball and flat specimens are used to calculate wear volumes and wear rates.

4.5 Friction forces are measured during the test and may be used to assess changes in the contact conditions or the kinetic friction coefficient as a function of time.

## 5. Significance and Use

5.1 This test method is designed to simulate the geometry and motions that are experienced in many types of rubbing components whose normal operation results in periodic reversals in the direction of relative sliding. The wear resulting from this mode of movement may differ from that experienced by the same materials sliding continuously in only one direction (unidirectional sliding) even for comparable durations of contact. Test loads and speeds are to be determined by the severity of the proposed application or purpose of the testing. Either of two sets of testing conditions (designated Procedures A and B) may be used.

## 6. Apparatus

6.1 *General Description*—Fig. 1 shows the arrangement for the reciprocating ball-on-flat wear test available on a commercial machine. The ball is rigidly mounted and has a spherical tip which moves back and forth across the surface of a polished flat specimen. Use of a spherical tip alleviates the alignment problems associated with flat-ended balls sliding on flat surfaces. Alternate configurations in which the flat moves and the ball specimen is fixed may be used. A provision is made for applying a uniform normal force (load) to the contact between the ball and the flat. Temperature measurement and control capability is provided to heat and monitor the flat specimen which may either be immersed in a lubricant bath or tested without lubricant. The tangential force can be measured continuously during oscillating contact and used to obtain friction coefficient data.<sup>3</sup>

<sup>3</sup> Machines of this type are described in *A Catalogue of Friction and Wear Devices*, American Society of Lubrication Engineers (now STLE) 838 Busse Highway, Park Ridge, IL, 1973, pp. 50–72.

6.2 *Specimen Drive*—A drive train, capable of providing smooth, reciprocating motion to the ball and overcoming the frictional resistance of the specimens at maximum load, is required. For example, a Scotch yoke drive mechanism can provide a smooth, sinusoidal velocity profile for the ball specimen relative to the flat specimen without the need for the motor to stop and reverse direction periodically. Stepper-type motors may also be used provided that the motion is smooth and uniform.

6.3 *Ball and Ball Specimen Holder*—The ball specimen may be a fixed bearing ball or any spherically tipped specimen as long as the sliding contact is equivalent to a ball on a flat plane. If a bearing ball is used, it shall be clamped tightly enough to prevent slippage during the test. The ball holder should be rigid enough so that the periodic reversal in the sliding direction does not result in tilting or other misalignment of the contact.

6.4 *Flat Specimen Holder*—The flat specimen is secured to the base of the machine to prevent slippage or buckling during the test. A variety of shapes and configurations for the flat specimen are possible. The primary criterion is that the coupon present a flat, horizontal surface to the ball specimen.

#### 6.5 *Instrumentation:*

6.5.1 *Friction Force*—A tension-compression load cell or similar force-sensing device may be used to measure the friction forces generated during sliding. Calibration of the friction force (see subsection 7.1.3) in both forward and reverse sliding directions is required. Since the direction of the friction force changes rapidly during the test, traditional strip-chart-type recorders may be too slow to follow these changes at high frequencies of reciprocation. A commercial version of this machine is available with a signal conditioner to rectify, and output the root-mean-square friction force to a strip-chart-recorder or to a computerized data acquisition system. The method of sensing and recording friction force during the test shall be described in the testing report.

6.5.2 *Test Duration*—In this test method, test duration is specified in seconds. To compute the sliding distance in metres or number of cycles, use the following:

$$X = 0.002 \times t \times f \times L \quad (1)$$

or

$$N = t \times f \quad (2)$$

where:

- $X$  = total sliding distance of the ball, m,
- $N$  = number of cycles in the test,
- $t$  = test time, s,
- $f$  = oscillating frequency, Hz (cycles/s), and
- $L$  = length of stroke, mm.

A cycle is defined as two stroke lengths (up and back). Electronic timers can be used to terminate the test. If a cycle-counter is available, this may be used instead of the timer, in which case Eq 2 will be used.

6.5.3 *Humidity*—The wear and friction of many materials is significantly affected by the moisture in the air. It is therefore required that the relative humidity (to an accuracy of  $\pm 3\%$ ) be measured before and during the test. Humidity can vary with air flow and in different parts of the same room, so the humidity sensor should be located as close to the test specimens as reasonably possible, in such a way that the air movement conditions are the same for humidity sensor as for the test specimens.

6.5.4 *Temperature*—The ambient temperature, in degrees Celsius, shall be measured and reported during room temperature tests. In full immersion, liquid-lubricated tests, the bath temperature shall be measured and reported.

## 7. Calibration

7.1 The parts of the apparatus that require calibration are (1) the loading system, (2) the motion drive (speed and stroke length), and (3) the friction force sensor.

7.1.1 *Loading System*—The load (normal force) applied to the specimen shall be checked periodically. In machines which apply the load by a spring/lever arrangement and indicate the load on a dial gage, this can be done by substituting a previously calibrated compression load cell for the specimen and checking the applied load indicated on the loading dial against the calibrated load cell output. Statically applied loads shall be kept constant within a maximum deviation of  $\pm 2.0\%$  of the test load. For example, permitted static error of a 25.0-N normal force would be  $\pm 0.5$  N. During oscillating tests, the normal force may vary slightly about the mean value due to the dynamics of the machine. This variation is to be expected.

7.1.2 *Motion Drive*—The oscillating frequency of the moving specimen shall be checked periodically against the drive motor setting to ensure that the rate of oscillation is known. (**Warning**—Due to inertial effects, differences in the loading and fixturing method become more significant as the oscillating frequency of the test is increased, and harmonic frequencies characteristic of the test machine must be avoided when selecting the oscillating frequency.)

7.1.3 *Friction Force Sensor*—The friction force sensor shall be calibrated periodically in both directions of load application. Depending on the machine, a fixture which applies a calibrating load in line with the normal point of contact between the ball and flat should be used.

## 8. Procedure

8.1 *Specimen Preparation*—The ball specimen and flat specimen shall be used either in a polished condition, or in a specified condition consistent with the application of interest. In a polished condition, the surface should be as free as possible from preparation artifacts such as grinding-induced cracks, gross grinding marks, and grain pull-out. Surface roughnesses of 0.02 to 0.05- $\mu\text{m}$   $R_a$  (arithmetic roughness) are typical.

8.2 Clean the specimens using the following procedure:

8.2.1 Wash with a mild liquid laboratory glassware cleaner,

8.2.2 Hot air dry,

8.2.3 Ultrasonically clean in acetone (2 min),

8.2.4 Hot air dry,

8.2.5 Ultrasonically clean in methanol (2 min), and

8.2.6 Hot air dry.

8.2.7 If there is considerable porosity in the specimens, it is necessary that they be baked dry for 4 h at a temperature greater than 150°C in a clean oven.

NOTE 1—Certain materials could be adversely affected by cleaning in solvents. Deviations from the prescribed cleaning procedure are permitted, but they shall be described in the report.

8.3 Clean the specimens after they are secured in place in the test fixture by wiping with acetone and then with methanol-moistened cotton swabs. It is possible that during mounting, some contamination was inadvertently placed on them, and this final cleaning will help alleviate the problem. Inspect the ball tip with a hand lens after it is mounted to ensure that there are no defects in the contact area.

8.4 Gently lower the ball specimen upon the flat specimen, and ensure that the reciprocating drive shaft motion is horizontal and parallel to the surface of the flat specimen. The height of the specimen or mount may require adjustment to ensure that this condition is fulfilled. Apply the prescribed test load. Confirm that the desired oscillating speed has been set before turning on the motor.

8.5 Two possible testing procedures, one for unlubricated tests (Procedure A), and one for high-contact stress-lubricated tests at elevated temperature (Procedure B), are given in 8.5.1. The procedure appropriate for the given materials and test severity should be selected. If neither procedure in 8.5.1 is determined to be suitable, other conditions may be used, but testing will not be in compliance with this test method. See the reporting requirements in Section 10 for reporting exceptions to Procedures A and B.

8.5.1 The two testing procedures are as follows.

8.5.1.1 *Procedure A*—Unlubricated wear testing at room temperature.

(1) Pin tip radius, 4.76 mm ( $\frac{3}{16}$  in.),

(2) Normal force, 25.0 N,

(3) Stroke length, 10.0 mm,

(4) Oscillating frequency, 5.0 Hz,

(5) Test duration, 16 min 40 s (sliding distance 100 m),

(6) Ambient temperature,  $22 \pm 3^\circ\text{C}$ ,

(7) Relative humidity, 40 to 60 %, and

(8) Lubrication, none applied.

8.5.1.2 *Procedure B*—Lubricated wear testing at elevated temperature.

(1) Pin tip radius, 4.76 mm ( $\frac{3}{16}$  in.),

(2) Normal force, 200.0 N,

(3) Stroke length, 10.0 mm,

(4) Oscillating frequency, 10.0 Hz,

(5) Test duration, 33 min 20 s (sliding distance 400 m),

(6) Temperature,  $150 \pm 2^\circ\text{C}$ ,

(7) Relative humidity, 40 to 60 %, and

(8) Lubrication, full immersion under the selected lubricant (see Note 2).

NOTE 2—This procedure requires full-immersion lubrication. If other methods, such as a controlled drip feeding system, are used to simulate certain applications, the provisions of 8.6 will apply.

8.5.2 When heated, liquid-lubricated tests are being conducted, as in Procedure B, apply the lubricant and heat the specimens to the selected temperature allowing them to equilibrate for not less than 5 min before applying the load and starting the test. Bath temperature shall be controlled to within a maximum deviation of  $\pm 2.0^\circ\text{C}$  from the desired temperature. A fresh supply of lubricant shall be used for each test unless the objective is to evaluate the effects of used lubricants on friction and wear.

8.5.3 Set the timer (or cycle counter), if available, for the selected test duration.

8.5.4 Start the friction (and temperature) recording equipment and initiate the test.

8.5.5 After the prescribed duration, stop the motor. Remove the normal force to recheck the zero point on the friction force recording system.

8.5.6 Allow specimens to cool, if heated, then remove the test specimens. To measure the wear, it is necessary to clean the specimens in such a way that the surface features are not altered. For unlubricated tests, a concentrated jet of air may be used to dispel the debris from the worn area of the specimens. For liquid-lubricated specimens, ultrasonic cleaning in a suitable solvent may be used. Specimens shall be thoroughly dried.

8.5.7 Examine the tip of the ball specimen to ensure that no rolling or other slippage has taken place. Any ball movement within the holder during the test invalidates the test results. Similarly, any slippage of the flat specimen in its fixture invalidates the test results.

8.6 *Alternative Testing Procedures*—To achieve certain simulation conditions, or for other technical reasons, Procedures A and B may not be suitable for a given reciprocating wear testing project. Modifications to the specific test conditions prescribed in Procedures A and B may be used for conducting such tests; however, in reporting the results, the specific parameters which are not in compliance with one of the standard testing procedures shall be specifically noted. A statement such as the following may then be used: “These tests are not in full compliance with the provisions of Test Method G133, Procedure A, because the normal force in these tests was 50.0 N, instead of 25.0 N as prescribed by the standard, and the stroke length was 5.0 mm, instead of 10.0 mm as prescribed by the standard. All other provisions of Test Method G133 have been followed.”

**9. Measurement and Calculation of Wear**

9.1 Depending upon the relative wear of ball and flat specimens, various assumptions about the geometric irregularity of the wear scars can be made. Fig. 2 shows several possible wear conditions. In Fig. 2(a), the flat material is much more wear-resistant than the ball material. In Fig. 2(b), the ball material is much more wear-resistant than the flat material. In Fig. 2(c), measurable wear occurs on both ball and flat materials.

9.2 *Wear of the Ball Specimen*—Owing to the nature of this type of test, the wear scar on the ball specimen may not always be circular or flat. Refer to the following which applies.

9.2.1 If the end of the ball appears flat, but not circular, the average of the maximum and minimum dimensions of the scar shall be computed and this value used as the effective ball scar diameter (*D*). Pin scar measurements may be made by removing the ball specimen holder and placing the wear scar portion under a reflecting microscope. A calibrated ocular or a photomicrograph of known magnification may be used to measure scar dimensions.

9.2.1.1 The wear volume ( $V_p$ ) for a flat ball wear scar of effective diameter *D* (the case in Fig. 2(a)), is found from the same relationship given in Test Method G99, Appendix X1.1.1:

$$V_p = (\pi h/6)[3D^2/4 + h^2] \tag{3}$$

where:

*h* = height of material removed, mm.

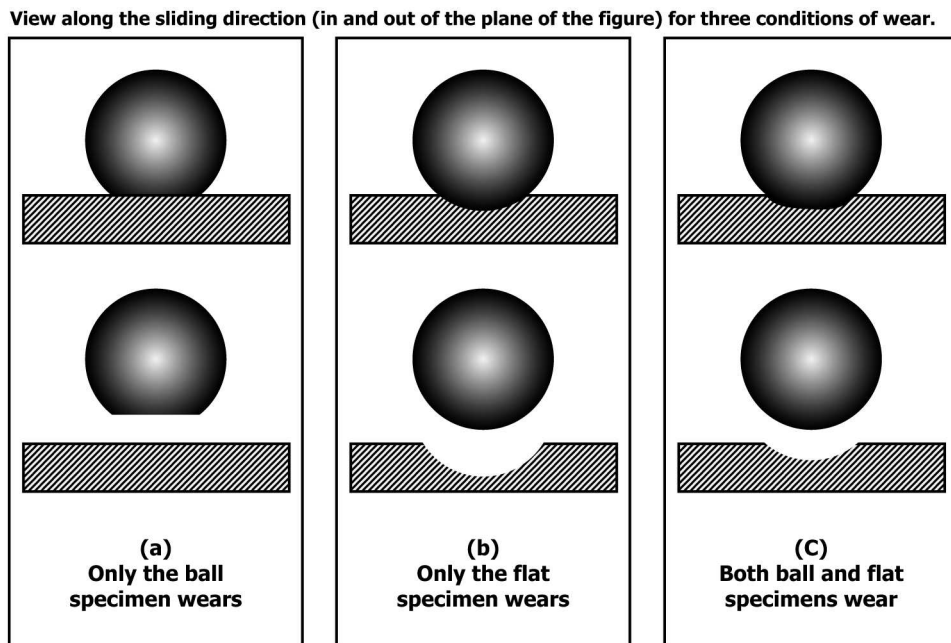

FIG. 2 Possible Situations for Differing Wear Resistance of Ball and Flat Specimens

Assuming a spherical wear volume, the height of material removed can be calculated from  $D$  as follows:

$$h = R - [R^2 - (D^2/4)]^{1/2} \quad (4)$$

where:

$R$  = original ball radius, mm.

**(Warning—**For lubricated tests in which there is minimal wear, it is possible to be misled in reading the apparent wear scar diameter of the ball tip optically because of elastic recovery. A small, shallow annulus surrounding the elastically deformed area may give the impression of wear, whereas little or no appreciable wear has actually occurred. Profilometry may be used to determine whether the wear scar is flat and consequently whether (Eq 3) and (Eq 4) can be used.)

9.2.2 If the ball tip is obviously worn, but the wear track profile on the flat specimen indicates that the ball is not entirely flat, as in Fig. 2(c), note those facts and either measure volume by an alternate method, fully describing the method used, or do not report wear volume.

NOTE 3—Various methods have been used to measure the wear volumes of non-flat ball tips.<sup>4</sup> These methods may be used and the results reported; however, a statement such as that given in 8.6 should be used to indicate that the calculation method is not in accordance with the provisions of this test method.

9.2.3 If there is only light abrasion or a few scratches on the ball specimen, the term “no measurable wear” may be used.

9.2.4 If the tip of the ball is obscured by an adherent deposit of wear debris, no measure of wear shall be reported, but the reason why the measurement cannot be made shall be reported.

9.3 *Wear of the Flat Specimen*—The wear volume of the flat specimen is computed from the length of the stroke and the average cross-sectional area of the wear track, as measured at locations equally spaced along its length. In most cases, the width and depth of the wear scar on the flat specimen will be relatively uniform throughout its length. If the areas of the three initial profiles differ by less than 25 %, three profiles will be sufficient. If wear is nonuniform, six cross-sectional profiles shall be obtained to compute the average track cross-sectional area. Generally, in calculating wear volume of the flat specimen, the minor geometric errors associated with the direction-reversal points at each end of the track can be neglected. **(Warning—**It is not recommended that continuous wear depth data obtained from position-sensing gages be used because of the possible complications arising from entrapped debris, thermal expansion due to frictional heating, hydrodynamic lift, and tribochemical films which can form in the wear interface under certain conditions.)

9.3.1 A cross section of the wear track is the area of the material removed from the original flat surface as viewed on a plane normal to the original surface and to the direction of sliding motion. Cross-sectional profiles may be obtained using a stylus-type instrument or its functional equivalent. On the printed profile made across the wear track, a straight line is drawn between the unworn areas on both sides of the wear scar and the cross-sectional area of the wear groove, below that reference line, is used to compute the wear volume. The cross-sectional area may be determined by planimetry, through the use of computerized digitizing tablet, or by importing the surface trace data directly into a computer program which permits the measurement of areas under profiles. Wear volume of the flat,  $V_f$  in mm<sup>3</sup>, is calculated from:

$$V_f = A \times L \quad (5)$$

where:

$A$  = average cross-sectional area of the track, mm<sup>2</sup>, and

$L$  = length of the stroke, mm.

## 10. Report

10.1 Report any unusual event such as noise, chattering, or excessive vibration which occurs during the test. Also, report any unusual frictional behavior, as indicated in 10.3.3. Test parameters to be reported should conform with either Procedure A or B. If procedures other than A or B are used, the report should explicitly state so, listing the conditions which are different than those described in 8.5.1.

10.2 Report the following:

10.2.1 Characterization of the ball and flat specimen materials. Information shall be sufficient to establish their source, chemical composition, processing history, surface treatment, and root-mean-square surface roughness. Commercial designations for materials should be given, if applicable. If a lubricant is used, provide its commercial name or other description, and any other properties needed to identify the source and traceability of the lubricant. Grain size and percent porosity of specimens may be reported, if applicable. If reporting grain size, indicate whether the grain size is nonuniform or duplex. See Test Methods E112 and E1181. Additional guidelines for reporting data are found in Guide G118.

NOTE 4—Quantities which have been measured on the same lot used for fabricating wear test specimens should be distinguished from those obtained on other lots of material (or handbook values) and assumed to apply to the given test specimens. Tests involving proprietary materials are specifically

<sup>4</sup>Whitenton, E. P., and Blau, P. J., “A Comparison of Methods for Determining Wear Volumes and Surface Parameters of Spherically-Tipped Sliders,” *Wear*, Vol 124, 1988, pp. 291–309.