



Designation: **F2613–16 F2613 – 16<sup>ε1</sup>**

## Standard Consumer Safety Specification for Children’s Chairs and Stools<sup>1</sup>

This standard is issued under the fixed designation F2613; the number immediately following the designation indicates the year of original adoption or, in the case of revision, the year of last revision. A number in parentheses indicates the year of last reappraisal. A superscript epsilon ( $\epsilon$ ) indicates an editorial change since the last revision or reappraisal.

---

<sup>ε1</sup> NOTE—Editorially corrected Fig. 4 and 6.8.1.1 in June 2016.

---

### INTRODUCTION

This consumer safety specification addresses incidents associated with children’s chairs and stools that were identified by the U.S. Consumer Product Safety Commission (CPSC). Incidents identified by the CPSC and addressed in this standard involve lacerations, fractures, pinches and amputations of children’s fingers in folding mechanisms. This specification also addresses structural integrity and labeling for the product. This specification is not intended to cover children’s chairs and stools that are either blatantly misused or abused. This specification is written within current state-of-the-art children’s chairs and stools and is intended to be updated if substantive information becomes available that necessitates additional requirements or justifies revision of existing requirements.

### 1. Scope

1.1 This consumer safety specification establishes testing requirements for structural integrity and performance requirements for children’s chairs and stools. It also provides requirements for labeling. The standard does not apply to products used in a commercial setting or to products that do not have a *rigid frame* such as bean bag chairs or foam chairs. This standard does not apply to seats with restraint systems. The term unit or product will refer to a child’s chair or stool.

1.2 This specification covers a chair or stool intended to be used by a single child who can get in and get out of the product unassisted and with a seat height 15 in. or less, with or without a rocking base.

1.3 No product produced after the approval date of this consumer safety specification shall, either by label or other means, indicate compliance with this specification unless it conforms to all applicable requirements contained herein, before and after all testing.

1.4 The values stated in inch-pound units are to be regarded as standard. The values given in parentheses are mathematical conversions to SI units that are provided for information only and are not considered standard.

1.5 *This standard does not purport to address all of the safety concerns, if any, associated with its use. It is the responsibility of the user of this standard to establish appropriate safety and health practices and determine the applicability of regulatory limitations prior to use.*

### 2. Referenced Documents

2.1 *ASTM Standards:*<sup>2</sup>

[D3359 Test Methods for Measuring Adhesion by Tape Test](#)

[F404 Consumer Safety Specification for High Chairs](#)

[F406 Consumer Safety Specification for Non-Full-Size Baby Cribs/Play Yards](#)

[F963 Consumer Safety Specification for Toy Safety](#)

[F1561 Performance Requirements for Plastic Chairs for Outdoor Use](#)

---

<sup>1</sup> This consumer safety specification is under the jurisdiction of ASTM Committee F15 on Consumer Products and is the direct responsibility of Subcommittee F15.59 on Children’s Folding Chairs.

Current edition approved May 1, 2016. Published May 2016. Originally approved in 2007. Last previous edition approved in 2014 as F2613 – 14. DOI: 10.1520/F2613-16-10.1520/F2613-16E01.

<sup>2</sup> For referenced ASTM standards, visit the ASTM website, [www.astm.org](http://www.astm.org), or contact ASTM Customer Service at [service@astm.org](mailto:service@astm.org). For *Annual Book of ASTM Standards* volume information, refer to the standard’s Document Summary page on the ASTM website.

## 2.2 Federal Regulations:<sup>3</sup>

16 CFR 1303 Ban of Lead-Containing Paint and Certain Consumer Products Bearing Lead-Containing Paint

16 CFR 1500.3 (c) (6) (vi) Definition of “Flammable Solid”

16 CFR 1500.48 Technical Requirements for Determining a Sharp Point In Toys and Other Articles Intended for Use By Children Under Eight Years of Age

16 CFR 1500.49 Technical Requirements for Determining a Sharp Metal or Glass Edge in Toys or Other Articles Intended for Use By Children Under Eight Years of Age

16 CFR 1501 Method for Identifying Toys and Other Articles Intended for Use By Children Under Three Years of Age Which Present Choking, Aspiration, or Ingestion Hazards Because of Small Parts

## 3. Terminology

### 3.1 Definitions of Terms Specific to This Standard:

3.1.1 *chairs with side containment*—a children’s chair or folding chair with armrests or otherwise designed in a shape which provides barriers in the vertical direction above the seating surface to the occupant’s left and right which can act like arms or other side structures.

3.1.2 *children’s chair, n*—seating furniture with a rigid frame that is intended to be used as a support for the body, limbs, or feet of a child when sitting or resting in an upright or reclining position.

3.1.3 *children’s stool, n*—children’s chair without back or armrests.

3.1.4 *conspicuous, adj*—describes a label that is visible, when the unit is in a manufacturer’s recommended use position, to a person standing near the unit at any one position around the unit but not necessarily visible from all positions.

3.1.5 *folding chair, folding stool, n*—a children’s chair or stool which can be folded for transport or storage.

3.1.6 *manufacturer’s recommended use position, n*—any position that is presented by the manufacturer in any descriptive or instructional literature as a normal, allowable, or acceptable configuration for use of the product. This specifically excludes positions that the manufacturer shows in a like manner in its literature to be unacceptable, unsafe, or not recommended.

3.1.7 *non-paper label, n*—label material (such as plastic or metal) that either will not tear without the aid of tools or tears leaving a sharply defined edge or labels made from fabric.

3.1.8 *occupant, n*—that individual who is in a product that is set up in one of the manufacturer’s recommended use positions.

3.1.9 *paper label, n*—any label material that tears without the aid of tools and leaves a fibrous edge.

3.1.10 *rigid frame, n*—a structure or support of stiff materials such as wood, plastic, or metal.

## 4. Calibration and Standardization

4.1 All testing shall be conducted on a concrete floor that may be covered with 1/8-in. (3-mm) thick vinyl flooring cover, unless test instructs differently.

4.2 The unit shall be completely assembled, unless otherwise noted, in accordance with the manufacturer’s instructions.

4.3 No testing shall be conducted within 48 h of manufacturing.

4.4 The product to be tested shall be preconditioned in a room with ambient temperature of 73 ± 9°F (23 ± 5°C) for at least 1 h prior to testing. Testing shall then be conducted within this temperature range.

4.5 All testing required by this specification shall be conducted on the same unit unless otherwise specified.

## 5. General Requirements

5.1 Prior to testing, any exposed wood parts shall be smooth and free of splinters.

5.2 There shall be no hazardous sharp points or edges as defined by 16 CFR 1500.48 and 16 CFR 1500.49 before or after testing to this specification.

5.3 There shall be no small parts, as defined by 16 CFR 1501, before testing or liberated as a result of testing in accordance with this specification.

5.4 The paint and surface coating on the product shall comply with 16 CFR 1303.

5.5 There shall be no flammable solids as defined in 16 CFR 1500.3 (c) (6) (vi) before or after testing in accordance with this specification.

5.6 Toy accessories attached to, removable from, or sold with a product, as well as their means of attachment, must meet applicable requirements of Consumer Safety Specification F963.

<sup>3</sup> Available from U.S. Government Printing Office Superintendent of Documents, 732 N. Capitol St., NW, Mail Stop: SDE, Washington, DC 20401, <http://www.access.gpo.gov>.

5.7 *Scissoring, Shearing, or Pinching (for folding chairs and folding stools only)*—A product, when folded, when being unfolded, or when in the manufacturer’s recommended use position, shall be designed and constructed to prevent injury to the occupant from any scissoring, shearing, or pinching when members or components rotate about a common axis or fastening point, slide, pivot, fold, or otherwise move relative to one another. Scissoring, shearing, or pinching that may cause injury shall not be permissible when the edges of the rigid parts admit a probe that is greater than 0.210 in. (5.30 mm) and less than 0.375 in. (9.50 mm) diameter at any accessible point throughout the range of motion of such parts.

5.7.1 Products with locking mechanisms that meet the requirements of 5.8.3, to prevent folding and unfolding by a child, shall only be evaluated in the manufacturer’s recommended use position.

5.8 *Folding Mechanisms and Hinges (for folding chairs and folding stools only)*—These requirements are intended to eliminate possible crushing, laceration, or pinching hazards that might occur in folding mechanisms and hinges. Examples are the sudden collapse or unexpected motion of a folding mechanism or hinge that produces a scissor action; and the changing clearances at the hinge line between two hinged portions, such that the gap will admit fingers at one position of the hinge but not at all positions.

5.8.1 *Folding Mechanisms*—Products shall have a locking device or other means to prevent unexpected or sudden movement or collapse of the product, or have adequate clearance to provide protection for the fingers, hands, and toes from crushing or laceration in the event of sudden movement or collapse of the product.

5.8.2 Locking devices and other means to prevent unexpected or sudden movement or collapse of the product shall engage automatically when the product is placed in any manufacturer’s recommended use position. Latches may be manually activated to allow placement into the use position but must engage automatically when released. During and upon completion of the testing in 6.1, the unit shall remain in its recommended use position.

5.8.3 If a unit is designed with a locking device:

5.8.3.1 Each single action device shall require a minimum force of 10 lbf (45 N) to activate the release mechanism when tested in accordance with 6.2.

5.8.3.2 Each double action locking device shall require either two consecutive actions, the first of which must be maintained while the second is carried out, or two separate and independent single action locking mechanisms that must be activated simultaneously to fully release. There are no force requirements for locking devices that are double action or are single action that are activated simultaneously.

5.8.4 *Hinge Line Clearance*—Products having a gap or clearance along the hinge line between a stationary portion and a movable portion shall be so constructed that, if the accessible gap at the hinge line will admit a 3/16-in. (5-mm) diameter rod, it will also admit a 1/2-in. (13-mm) diameter rod at all positions of the hinge.

5.8.5 No product shall give the appearance of being in any manufacturer’s recommended use position unless the locking device is fully engaged.

5.9 *Circular Holes in Rigid Materials*—This requirement is intended to prevent finger entrapment (which may cut off blood circulation) in accessible holes in sheet metal and other rigid materials (non-circular holes are believed to present no significant hazard of cutting off blood circulation in entrapped fingers). If an accessible, circular hole in any rigid material less than 0.062 in. (1.58 mm) in thickness can admit a 1/4-in. (6-mm) diameter rod to a depth of 3/8 in. (10 mm) or greater, it shall also admit a 1/2-in. (13-mm) diameter rod. The product shall be evaluated in all manufacturer’s recommended use positions.

5.9.1 *Rationale*—Based on requirements for toys from Consumer Safety Specification F963, since the age range of children using chairs and stools is similar to that for children using toys.

5.10 *Labeling:*

5.10.1 Warning labels (whether paper or non-paper) shall be permanent when tested in accordance with 6.3.

5.10.2 Warning statements applied directly onto the surface of the product by hot stamping, heat transfer, printing, wood burning, and so forth shall be permanent when tested in accordance with 6.4.

5.10.3 Non-paper labels shall not liberate small parts when tested in accordance with 6.5.

5.11 *Protective Components*—If the child can grasp components between the thumb and forefinger or teeth (such as caps, sleeves, or plugs used for protection from sharp edges, points, or entrapment of fingers or toes), or if there is at least a 0.040-in. (1.00-mm) gap between the component and its adjacent parent component, such component shall not be removed when tested in accordance with 6.6.

5.12 *Strength Requirements*—Products shall be tested in accordance with 6.7, and shall not generate any sharp edges, sharp corners, sharp points, or any scissoring, shearing or pinch points. The product shall remain functional upon completion of the testing. Some deformation of the product is permissible provided that the preceding requirements are met. These requirements shall apply to products with either rigid seating surfaces or sling-type flexible seating surfaces suspended from a frame (for example, director’s chairs) regardless of whether the available seating width of the product is limited by a structure such as arm rests.

5.13 *Stability*—All products shall not tip over backwards when tested in accordance with 6.8.1 and 6.8.2. Chairs with Side Containment shall not tip over sideways when tested in accordance with 6.8.1 and 6.8.3. Tip over occurs when the product moves past equilibrium and begins to overturn.

## 6. Test Methods

### 6.1 Locking Mechanisms (for folding chairs and folding stools only):

- 6.1.1 Erect the product in accordance with any manufacturer's instructions.
- 6.1.2 Secure the product so that the normal folding motion is not impeded.
- 6.1.3 Apply a force of 45 lbf (200 N) to the product in the direction normally associated with folding. Apply the force gradually over a 5-s period and maintain for an additional 10 s before releasing the force.
- 6.1.4 Perform this procedure five times within a 2-min period.

6.2 *Locking Test Method (for folding chairs and folding stools only)*—With the product in each of the manufacturer's recommended use positions, gradually apply a force of 10 lbf (45 N) to the locking mechanism in the direction tending to unlock it. The locking mechanism shall not unlock until a minimum force of 10 lbf (45 N) has been achieved.

### 6.3 Permanency of Labels and Warnings:

6.3.1 A paper label (excluding labels attached by a seam) shall be considered permanent if, during an attempt to remove it without the aid of tools or solvents, it cannot be removed, it tears into pieces upon removal, or such action damages the surface to which it is attached.

6.3.2 A non-paper label (excluding labels attached by a seam) shall be considered permanent if, during an attempt to remove it without the aid of tools or solvents, it cannot be removed or such action damages the surface to which it is attached.

6.3.3 A warning label attached by a seam shall be considered permanent if it does not detach when subjected to a 15-lbf (67-N) pull force applied in any direction most likely to cause failure using a 3/4-in. (19-mm) diameter clamp surface (see Fig. 1). Gradually apply the force over 5 s and maintain for an additional 10 s.

### 6.4 Adhesion test for warnings applied directly onto the surface of the product.

- 6.4.1 Apply the tape test defined in Test Method B—Cross-Cut Tape Test of Test Methods D3359, eliminating parallel cuts.
- 6.4.2 Perform this test once in each different location where warnings are applied.
- 6.4.3 The warning statements shall be considered permanent if the printing in the area tested is still legible and attached after being subjected to this test.

6.5 A non-paper label, during an attempt to remove it without the aid of tools or solvents, shall not be removed or shall not fit entirely within the small parts cylinder defined in 16 CFR 1501 if it can be removed.

### 6.6 Removal of Protective Components:

- 6.6.1 Test components in accordance with each of the following methods in the sequence listed:
- 6.6.2 Secure the unit so that it cannot move during the performance of the following tests.
- 6.6.3 *Torque Test*—Apply a torque of 3 lbf-in. (0.5-Nm) gradually within a period of 5 s in a clockwise direction until a rotation of 180° from the original position has been attained or 3 lbf-in. (0.5-Nm) has been reached. Maintain the torque or maximum rotation for an additional 10 s. Maintain, then remove the torque and permit the test components to return to a relaxed condition, then repeat this procedure in the counterclockwise direction.

#### 6.6.4 Tension Test:

6.6.4.1 Attach a force gauge to the component cap, sleeve, or plug by any suitable device. For components having a gap of 0.040 in. (1.0 mm) or more between the rear surface of the component and the structural member of the unit to which they are attached, a clamp such as shown in Fig. 1 may be a suitable device.

6.6.4.2 Be sure the attachment device does not compress or expand the component to hinder removal of the component.

6.6.4.3 Gradually apply a 15-lbf (67-N) force in the direction that would normally be associated with the removal of the component. Apply the force within 5 s and maintain for an additional 10 s.

### 6.7 Static Load and Fatigue Testing:

6.7.1 Each product will be erected in the manufacturer's recommended use position for testing. If more than one position is recommended, the product will be tested in each recommended use position.

6.7.2 Determine the available seat width of the product. The seat width shall be measured in a plane 2.0 in. (5.1 cm) above the seating surface at the widest point parallel to the front of the chair. For products with seating surfaces that are limited by a structure, use a gauge similar to that shown in Fig. 2 and Fig. 3 to determine the available seat width.

6.7.3 Index the available seat width as determined in 6.7.2 to the maximum seated hip breadth in Table 1 to determine the corresponding weight.

6.7.4 The test load for the fatigue test shall be the greater of: (1) the weight indicated in Table 1 as determined in 6.7.3; or, (2) the manufacturer's maximum recommended weight. The test load for the static load test shall be three times the weight used in the fatigue test.

6.7.5 Place the product on a horizontal plane.

6.7.6 Each test load shall be distributed through an 8-in. diameter wood block positioned in the center of the seating surface.

6.7.6.1 *Static Load Test*—The load shall be applied vertically down to the seating surface over a period of 10 s and shall remain in place for 60 s. It is permissible to use a fixture to apply the load to avoid cantilevering of the load to the product. The static load shall be applied once.

15 lbf (67 N) MAX TENSION

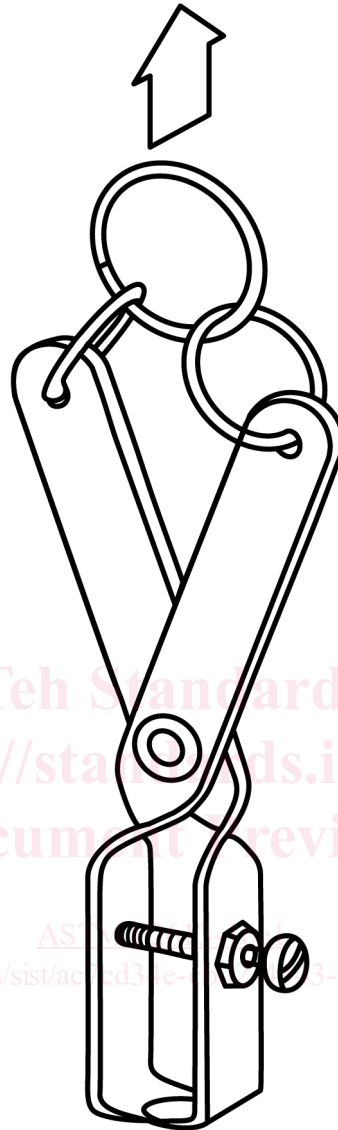
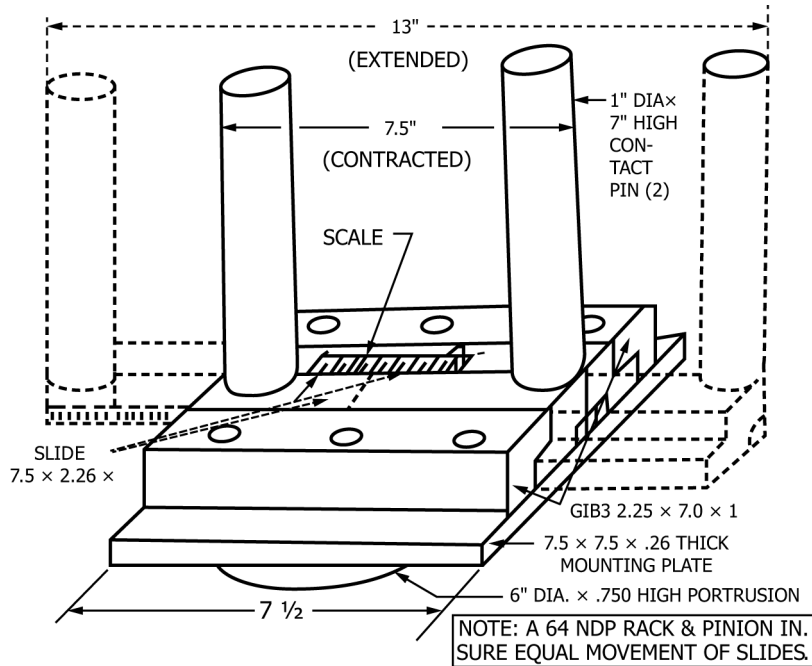

FIG. 1 Tension Test Adapter/Clamp

6.7.6.2 *Fatigue Test (Performed on a Separate Sample)*—The load shall be applied vertically down to the seating surface over a period of 2 s, held for a period of 5 s, and then be totally removed from the product. This cycle shall be repeated for 500 cycles at a rate of 6 cycles per minute.



- NOTE:
1. EACH SLIDE MOVES EQUALLY 2.75 IN FROM THE CONTRACTED POSITION.
  2. GAGE IS PLACED IN CENTER OF SEATING POSITION
  3. EXTENSION SLIDES ARE MOVED OUT UNTIL THEY CONTACT THE ARMREST OR UNTIL THEY REACH 14 INCHES.
  4. THE DIMENSION OF SPACE BETWEEN THE ARMS IS THEN INDEXED TO TABLE "N" FOR LOAD VALUE.

FIG. 2 Chair Seating Width Gauge

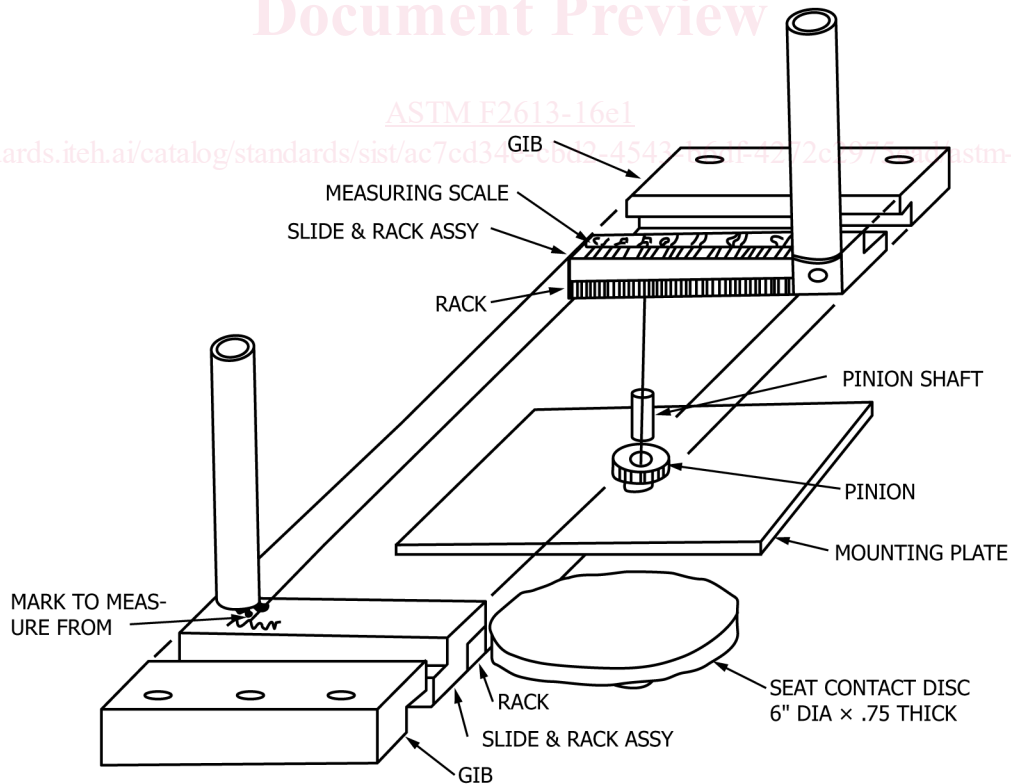

FIG. 3 Chair Seating Width Gauge—Exploded View

6.8 Stability Test Method: