



Designation: **D1084—08 D1084 – 16**

Standard Test Methods for Viscosity of Adhesives¹

This standard is issued under the fixed designation D1084; the number immediately following the designation indicates the year of original adoption or, in the case of revision, the year of last revision. A number in parentheses indicates the year of last reappraisal. A superscript epsilon (ϵ) indicates an editorial change since the last revision or reappraisal.

This standard has been approved for use by agencies of the U.S. Department of Defense.

1. Scope

1.1 These test methods cover the determination of the viscosity of free-flowing adhesives.

1.1.1 The limitation of this test method to self-leveling adhesives eliminates thixotropic and plastic materials whose viscosity is a function of the rate of stirring and previous history of the adhesive.

1.2 The values stated in SI units are to be regarded as the standard. The values in parentheses are for information only.

1.3 *This standard does not purport to address all of the safety concerns, if any, associated with its use. It is the responsibility of the user of this standard to establish appropriate safety and health practices and determine the applicability of regulatory limitations prior to use.*

2. Referenced Documents

2.1 *ASTM Standards:*²

[D88 Test Method for Saybolt Viscosity](#)

[D115 Test Methods for Testing Solvent Containing Varnishes Used for Electrical Insulation](#)

[D562 Test Method for Consistency of Paints Measuring Krebs Unit \(KU\) Viscosity Using a Stormer-Type Viscometer](#)

[D907 Terminology of Adhesives](#)

[D1200 Test Method for Viscosity by Ford Viscosity Cup](#)

[D1545 Test Method for Viscosity of Transparent Liquids by Bubble Time Method](#)

[D1601 Test Method for Dilute Solution Viscosity of Ethylene Polymers](#)

[D2556 Test Method for Apparent Viscosity of Adhesives Having Shear-Rate-Dependent Flow Properties Using Rotational Viscometry](#)

2.2 *ISO Document:*³

[ISO 2555 Plastics — Resins in the Liquid State or as Emulsions or Dispersions — Determination of Apparent Viscosity by the Brookfield Test Method](#)

3. Terminology

3.1 *Definitions:*

3.1.1 Many terms in these test methods are defined in Terminology [D907](#).

3.1.2 *viscosity, n—of a liquid*, the resistance to flow expressed as the ratio of the applied stress to the resulting rate of shearing strain (see Newtonian behavior and thixotropy). (Compare consistency.)

3.2 *Definitions of Terms Specific to This Standard:*

3.2.1 *viscosity, n*—the ratio of shear stress to shear rate. The viscosity of a liquid is a measure of the internal friction of the liquid in motion. The unit of dynamic viscosity is the ~~poise~~, Pascal (poise), which is expressed as dyne-seconds per square centimetre. For a Newtonian liquid, the viscosity is constant at all shear rates. For a non-Newtonian liquid, viscosity will vary depending on shear rate.

¹ These test methods are under the jurisdiction of ASTM Committee [D14](#) on Adhesives and are the direct responsibility of Subcommittee [D14.10](#) on Working Properties. Current edition approved ~~Feb. 1, 2008~~ ~~May 1, 2016~~, February 2008, June 2016. Originally approved in 1950. Last previous edition approved in ~~2005~~ ~~2008~~ as ~~D1084—97 (2005)~~ ~~D1084 – 08~~, DOI: ~~10.1520/D1084-08-10.1520/D1084-16~~.

² For referenced ASTM standards, visit the ASTM website, www.astm.org, or contact ASTM Customer Service at service@astm.org. For *Annual Book of ASTM Standards* volume information, refer to the standard's Document Summary page on the ASTM website.

³ Available from American National Standards Institute (ANSI), 25 W. 43rd St., 4th Floor, New York, NY 10036, <http://www.ansi.org>.

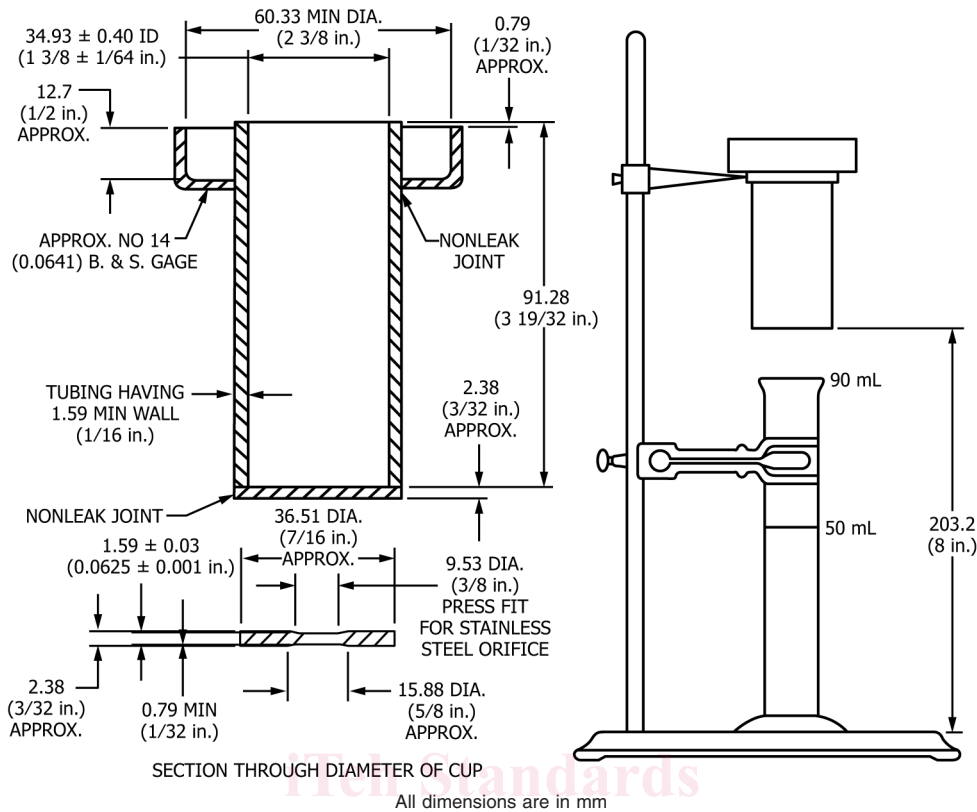

FIG. 1 Consistency Cups and Apparatus Assembly (Test Method A)

4. Significance and Use

4.1 Several test methods are noted for viscosity determination of Newtonian and near Newtonian flow characteristics. (For adhesives not fitting into this category, Test Method D2556 should be considered.) Four test methods are covered as follows:

4.1.1 *Method A* is applicable only to adhesives that will deliver 50 mL in a steady uninterrupted stream from one of the cups described in Section 5.

4.1.2 *Method B* is intended for measuring the viscosity of adhesives covering a range from 0.05 Pa · s to 200 Pa · s (50 to 200 000 cP) and is limited to materials that have or approach Newtonian flow characteristics.

4.1.3 *Method C* is intended primarily as a control method for determining the viscosity of adhesives that have or approach Newtonian flow characteristics.

4.1.4 *Method D* is intended primarily as a control method for determining the viscosity of materials that have an equivalent viscosity no greater than approximately 3000 eP-mPa · s (cP) and is limited to materials that have or approach Newtonian flow characteristics.

TEST METHOD A

5. Apparatus

5.1 The apparatus (Fig. 1) consists of a set of four viscosity cups so designed as to deliver 50 mL of the sample in from 30 to 100 s at a temperature of 23 ± 0.5°C (73.4 ± 0.9°F).

5.1.1 Four consistency cups constitute a set as follows:

	Diameter of Orifice, in.
First Cup	0.07 ± 0.0001
Second cup	0.10 ± 0.0001
Third cup	0.15 ± 0.0001
Fourth cup	0.25 ± 0.0001

5.1.2 Cups made of brass or bronze. Orifice disks made of 18 % Chromium, 8 % Nickel stainless steel. The diameter of the Orifice pressed in the cup shall be stamped on the cup.

5.1.3 Fractional dimensions subject to permissible variations of ±0.01 in., unless otherwise specified.

6. Procedure

6.1 Bring the sample to be tested and the viscosity cup to a temperature of $23 \pm 0.5^{\circ}\text{C}$ ($73.4 \pm 0.9^{\circ}\text{F}$) (preferably in a constant-temperature room). Then mount the consistency cup in the clamp provided for the purpose and place the receiving cylinder in position. With the outlet of the cup closed by means of the finger, pour the sample into the cup until it is filled to overflowing. Strike off the excess with a straightedge, and then remove the finger from over the outlet and allow the sample to flow into the receiving cylinder. Determine the number of seconds from the time the finger is removed from the orifice until the top of the meniscus reaches to 50-mL mark on the cylinder by a stop watch and record as the viscosity of the material.

7. Report

7.1 Report the following:

7.1.1 Complete identification of the adhesive tested, including type, source, manufacturer's code numbers, form, date of test, date of manufacture, etc.,

7.1.2 Conditioning procedure used for samples prior to testing,

7.1.3 Number of tests made, and

7.1.4 Average consistency in seconds and the number of the viscosity cup used.

TEST METHOD B

8. Procedure

8.1 Refer to ISO 2555 for this test method.

TEST METHOD C

9. Apparatus

9.1 *Viscometer*—A Stormer viscosimeter with double flag paddle-type rotor as specified in Test Method **D562**, or an equivalent apparatus, in good repair and a spindle that spins freely when started without the paddle.

9.2 *Containers*—Round friction-top metal cans having a capacity of 1 qt (0.9 L). Nonstandard containers may be used by mutual agreement, when necessary to prevent corrosion or other deleterious effects of metal cans.

9.3 *Thermometer*—A precision thermometer with graduations not greater than 0.2°C (0.36°F) divisions.

9.4 *Timer*—A stop watch or suitable timer measuring to 0.2 s.

10. Procedure

10.1 *Conditioning*—Bring the containers holding the samples to be tested and the paddle to be used to a temperature of $23 \pm 0.5^{\circ}\text{C}$ (73.4°F) (preferably in a constant-temperature room), and maintain the sample uniformly at this standard temperature throughout the test. Protect adhesives containing volatile solvents from evaporation during conditioning. If special conditioning methods are necessary, such as the use of a circulating water bath. Report this in **11.1.2**.

10.2 *Adjustment*—Prepare the instrument for use by raising the weight to the top by winding up the cord with the ratchet provided for that purpose. Set the revolution counter at 10 revolutions below the zero mark. Use a falling weight of such magnitude that a minimum time of 20 s is required for 100 revolutions of the paddle when the test is conducted as specified in **10.2**. Choose the weight from the series 50, 100, 200, 500, and 1000 g. Fasten the paddle securely on the shaft, place the container on the platform, and raise until the surface of the adhesive just reaches the mark on the stem of the paddle. This ensures uniform depth of immersion of the paddle.

10.3 *Determination*—Release the brake on the large cog wheel, and start the timing device when the needle on the revolution counter passes the zero mark. Note the time for 100 revolutions accurately to the closest 0.2 s. Make a minimum of three determinations.

11. Report

11.1 Report the following:

11.1.1 Complete identification of the adhesive tested, including type, source, ~~manufacturer's~~ manufacturer's code numbers, form, date of test, date of manufacture, etc.,

11.1.2 Conditioning procedure employed, including time elapsed between various operations used in the preparation of the adhesive mix,

11.1.3 Details of nonstandard containers, if used,

11.1.4 Temperature of the sample at the conclusion of the test,

11.1.5 Weight used,