

INTERNATIONAL STANDARD

**ISO
3875**

Second edition
1990-07-01

Acceptance conditions for external cylindrical centreless grinding machines — Testing of the accuracy

iTeh **STANDARD PREVIEW**

*Conditions de réception des machines à rectifier les surfaces de révolution
extérieures, sans centres — Contrôle de la précision*
(standards.iteh.ai)

ISO 3875:1990

[https://standards.iteh.ai/catalog/standards/sist/5b4ce775-5c0b-48a1-a0fc-
e47104375926/iso-3875-1990](https://standards.iteh.ai/catalog/standards/sist/5b4ce775-5c0b-48a1-a0fc-e47104375926/iso-3875-1990)



Reference number
ISO 3875 : 1990 (E)

Foreword

ISO (the International Organization for Standardization) is a worldwide federation of national standards bodies (ISO member bodies). The work of preparing International Standards is normally carried out through ISO technical committees. Each member body interested in a subject for which a technical committee has been established has the right to be represented on that committee. International organizations, governmental and non-governmental, in liaison with ISO, also take part in the work. ISO collaborates closely with the International Electrotechnical Commission (IEC) on all matters of electrotechnical standardization.

Draft International Standards adopted by the technical committees are circulated to the member bodies for voting. Publication as an International Standard requires approval by at least 75 % of the member bodies casting a vote.

International Standard ISO 3875 was prepared by Technical Committee ISO/TC 39, *Machine tools*.

This second edition cancels and replaces the first edition (ISO 3875 : 1980), of which it constitutes a technical revision.

© ISO 1990

All rights reserved. No part of this publication may be reproduced or utilized in any form or by any means, electronic or mechanical, including photocopying and microfilm, without permission in writing from the publisher.

International Organization for Standardization

Case postale 56 • CH-1211 Genève 20 • Switzerland

Printed in Switzerland

Acceptance conditions for external cylindrical centreless grinding machines — Testing of the accuracy

1 Scope

This International Standard describes, with reference to ISO 230-1, both geometrical and practical tests on general purpose and normal accuracy external cylindrical centreless grinding machines and gives the corresponding permissible deviations which apply.

It deals only with the verification of accuracy of the machine. It does not apply to the testing of the running of the machine (vibrations, abnormal noises, stick-slip motion of components etc.), or to its characteristics (speeds, feeds etc.) which should generally be checked before the accuracy is tested.

This International Standard also gives the nomenclature used for the principal parts of the machine.

NOTE — In addition to terms used in the three official ISO languages (English, French and Russian), this International Standard gives the equivalent terms in the German language; these are published under the responsibility of the member body for Germany, F.R. (DIN). However, only the terms given in the official languages can be considered as ISO terms.

2 Normative references

The following standards contain provisions which, through reference in this text, constitute provisions of this International Standard. At the time of publication, the editions indicated were valid. All standards are subject to revision, and parties to agreements based on this International Standard are encouraged to investigate the possibility of applying the most recent editions of the standards indicated below. Members of IEC and ISO maintain registers of currently valid International Standards.

ISO 230-1 : 1986, *Acceptance code for machine tools — Part 1: Geometric accuracy of machines operating under no-load or finishing conditions.*

ISO 1101 : 1983, *Technical drawings — Geometrical tolerancing — Tolerancing of form, orientation, location and run-out — Generalities, definitions, symbols, indications on drawings.*

3 Preliminary remarks

3.1 In this International Standard, all the dimensions and permissible deviations are expressed in millimetres and in inches.

3.2 To apply this International Standard, reference should be made to ISO 230-1 especially for the installation of the machine before testing, the warming up of spindles and other moving parts, the description of measuring methods and the recommended accuracy of testing equipment.

3.3 The sequence in which the geometrical tests are given is related to the sub-assemblies of the machine, and this in no way defines the practical order of testing. In order to make the mounting of instruments or gauging easier, tests may be applied in any order.

3.4 When inspecting a machine, it is not always necessary to carry out all the tests described in this International Standard. It is up to the user to choose, in agreement with the manufacturer, those relating to the properties which are of interest, but these tests are to be clearly stated when ordering a machine.

3.5 Practical tests shall be made with finishing cuts and not with roughing cuts which are liable to generate appreciable cutting forces.

3.6 When the tolerance is established for a measuring range different from that given in this International Standard (see ISO 230-1 : 1986, 2.311) it should be taken into consideration that the minimum value of tolerance is 0,002 mm (0,000 08 in).

4 Nomenclature

See figure 1 and table 1.

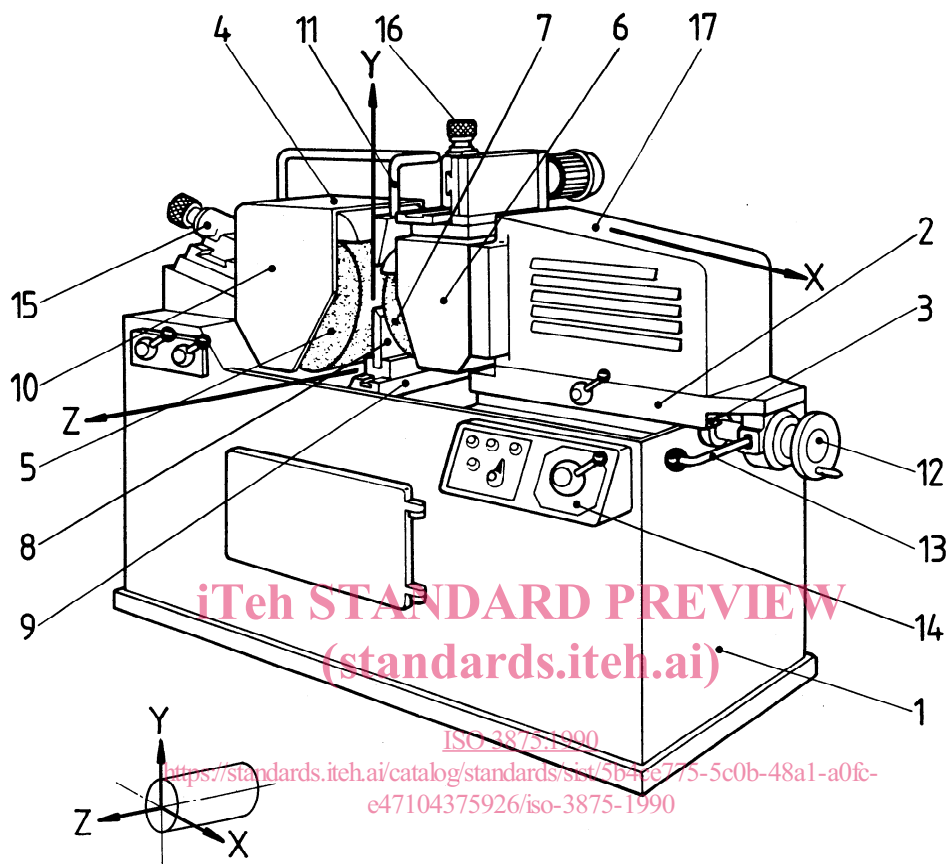

Figure 1

Table 1

Reference	Designation			
	English	French	Russian	German
1	Bed	Banc	Станина	Bett
2	Saddle, slide	Chariot	Салазки	Schlitten
3	Saddle guideway	Guidage de chariot	Направляющие салазок	Schlittenführung
4	Grinding spindle head	Poupée porte-meule de travail	Шлифовальная бабка	Schleifspindelstock
5	Grinding wheel	Meule de travail	Шлифовальный круг	Schleifscheibe
6	Regulating wheel spindle head	Poupée porte-meule d'entraînement	Бабка ведущего круга	Regelscheibenspindelstock
7	Regulating wheel	Meule d'entraînement	Ведущий круг	Regelscheibe
8	Work rest	Appui porte-pièce	Опорный нож	Werkstückauflage
9	Work rest support	Support d'appui porte-pièce	Стойка опорного ножа	Werkstückauflagehalterung
10	Wheel guard	Capot de sécurité	Защитный кожух шлифовального круга	Sicherheitsschutzhaube
11	Coolant pipe	Tuyau de réfrigérant	Трубопровод охлаждающей жидкости	Kühlmittelleitung
12	Infeed handwheel	Volant d'approche	Маховичок врезной подачи	Zustellhandrad
13	Adjusting lever	Levier de déplacement	Установочный рычаг	Verstellhebel
14	Control panel	Tableau de commande	Пульт управления	Steuertafel
15	Dressing attachment for grinding wheel	Dispositif de dressage pour meule de travail	Прибор правки шлифовального круга	Abrichtgerät für Schleifscheibe
16	Dressing attachment for regulating wheel	Dispositif de dressage pour meule d'entraînement	Прибор правки ведущего круга	Abrichtgerät für Regelscheibe
17	Angular housing = Bearing angle	Capot de chariot	Поворотный корпус (для регулирования подачи)	Winkelgehäuse = Lagerwinkel

5 Acceptance conditions and permissible deviations

5.1 Geometrical tests

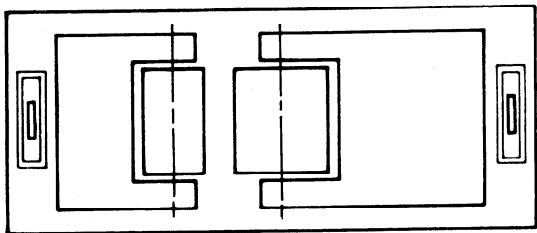
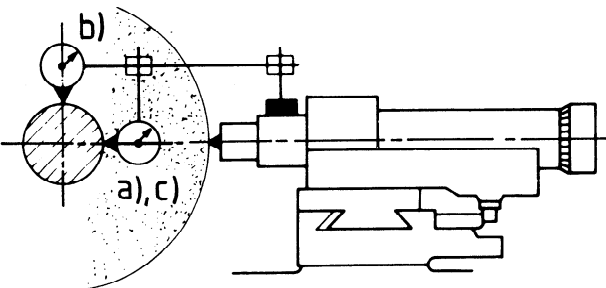
No.	Diagram	Object
G0		<p>Levelling of the machine.</p>
G1	<p style="text-align: center; color: red;">iTeh STANDARD PREVIEW (standards.iteh.ai)</p> <p style="text-align: center; color: red;">ISO 3875:1990 https://standards.iteh.ai/catalog/standards/sist/5b4ce775-5c0b-48a1-a0fc-e47104375926/iso-3875-1990</p> <p style="text-align: center; color: red;">A – Grinding wheel dresser</p> 	<p>Checking of movement of the dressing tool for</p> <ul style="list-style-type: none"> a) straightness of movement in the plane of action; b) parallelism of movement to the grinding spindle axis in a plane perpendicular to the plane of action; c) parallelism of movement to the grinding spindle axis in the plane of action. <p>NOTE – Test c) applies only for machines with fixed dresser and non-adjustable template.</p>

Permissible deviation		Measuring instruments	Observations and references to the ISO 230-1 : 1986 acceptance code
mm	in		
0,1/1 000	0,004/40	Precision levels	Subclause 3.1 This test should be carried out only when instructions on levelling have not been provided by the manufacturer.
<p>iTeh STANDARD PREVIEW (standards.iteh.ai)</p> <p>ISO 3875:1990 https://standards.iteh.ai/catalog/standards/sist/5b4ce775-5c0b-48a1-a0ff-e47104375926/iso-3875-1990</p>		Dial gauge, test mandrel and master straightedge	Subclauses 5.231, 5.233 and 5.422.3 The dial gauges shall be mounted on the dressing tool holder with their styli contacting the test mandrel, which is inserted in the grinding wheel spindle, in the plane of action and in a plane perpendicular to the plane of action. The dressing slide shall be moved with a normal working feed. The measuring distance shall be equal to the maximum width of the grinding wheel. If the machine is provided with a copying mechanism, the copying pin should be engaged with a normal working pressure (stated by the manufacturer) against the master straightedge. Indicated permissible deviations relate to the position of the diamond point. The measuring method gives the sum of errors from the dressing mechanism.
a) 0,003 for any measuring length of 300	a) 0,000 12 12		
b) 0,05 for any measuring length of 300	b) 0,002 12		
c) 0,03 for any measuring length of 300	c) 0,001 2 12		

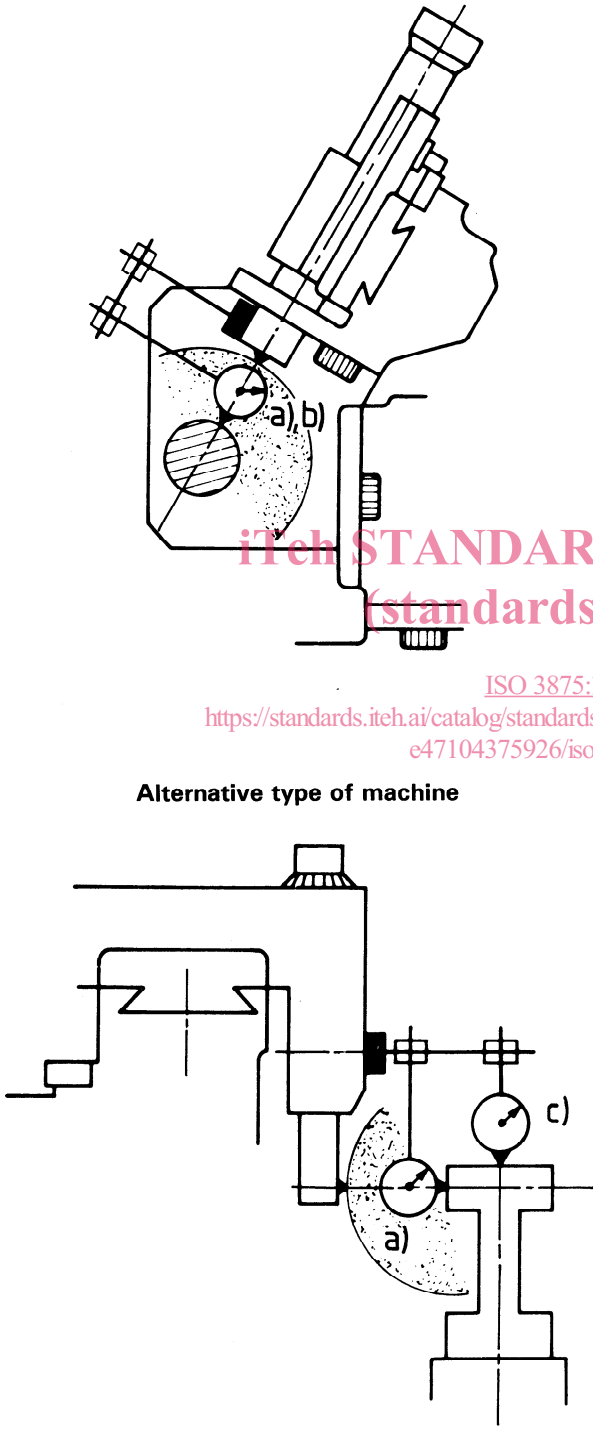
No.	Diagram	Object
G2	 <p style="text-align: center;">ISO 3875:1990 https://standards.iteh.ai/catalog/standards/sist/5b4de775-5c0b-48a1-a0fc-e47104375926/iso-3875-1990</p> <p style="text-align: center;">Alternative type of machine</p>	<p style="text-align: center;">B – Regulating wheel dresser</p> <p>Checking of movement of the dressing tool for</p> <p>a) straightness of movement in the plane of action;</p> <p>b) parallelism of movement relative to the regulating spindle axis in the plane of action;</p> <p>NOTE – Test b) refers only to machines with fixed dresser and non-adjustable template.</p> <p>c) parallelism of movement relative to the work support plane.</p> <p>NOTE – Test c) refers only to machines with a non-gradient slide in the vertical plane.</p>

Permissible deviation		Measuring instruments	Observations and references to the ISO 230-1 : 1986 acceptance code
mm	in		
			Subclauses 5.231, 5.233 and 5.422.3
a) 0,003 for any measuring length of 300	a) 0,000 12 12	Dial gauge, test mandrel, master straightedge and test straightedge	The dial gauges shall be mounted on the dressing tool holder with their styli contacting the test mandrel or straightedge.
b) 0,03 for any measuring length of 300	b) 0,001 2 12		The dressing slide shall be moved with a normal working feed. The measuring distance shall be equal to the maximum width of the regulating wheel.
c) 0,05 for any measuring length of 300	c) 0,002 12		If the machine is provided with a copying mechanism, the copying pin shall be engaged with a normal working pressure against the master straightedge.
			Indicated permissible deviations relate to the position of the diamond point.
			The measuring method gives the sum of errors from the dressing mechanism.

iTeH STANDARD PREVIEW
(standards.iteh.ai)
ISO 3875:1990
<https://standards.iteh.ai/catalog/standards/sist/51515-5c08-41a0-47104375926/iso-3875-1990>

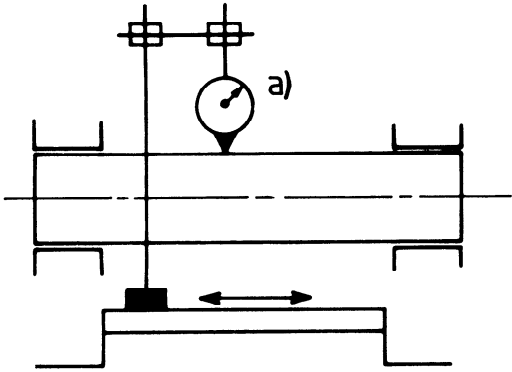
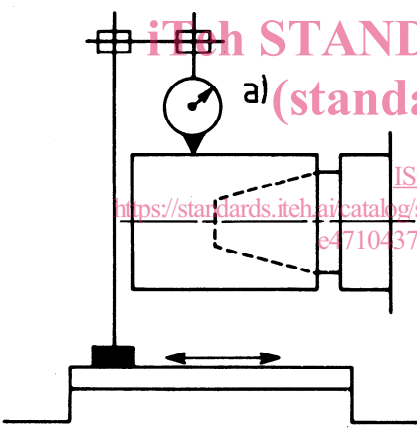
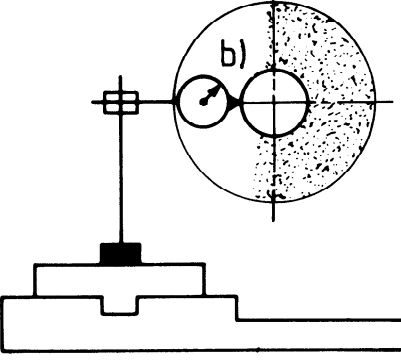
No.	Diagram	Object
G3	 <p data-bbox="367 907 694 940">Alternative type of machine</p>	<p data-bbox="1005 873 1348 907">C – Work rest blade location</p>
		<p data-bbox="933 974 1420 1064">a) Checking of parallelism of the work support plane to the grinding spindle axis in the vertical plane.</p>
		<p data-bbox="933 1624 1420 1736">b) Checking of parallelism of the vertical datum face to the regulating spindle axis or the grinding spindle axis in the horizontal plane.</p> <p data-bbox="933 1758 1420 1848">NOTE – Test b) applies only for machines with fixed work rest blade, fixed dresser and non-adjustable template.</p>

Permissible deviation		Measuring instruments	Observations and references to the ISO 230-1 : 1986 acceptance code
mm	in		
a) 0,05 for any measuring length of 300	a) 0,002 12	Dial gauge and test mandrel	Subclauses 5.412.1 and 5.412.4 The dial gauge shall be mounted on the work rest blade location surfaces with the stylus contacting the test mandrel.
b) 0,03 for any measuring length of 300	b) 0,001 2 12		

iTeH STANDARD PREVIEW
(standards.iteh.ai)
ISO 3875:1990
<https://standards.iteh.ai/catalog/standards/sist/5b4ce775-5c06-48a1-a0fc-e47104375926/iso-3875-1990>