



Designation: **D93—15a D93 – 16**



Designation: **34/99**

Standard Test Methods for Flash Point by Pensky-Martens Closed Cup Tester¹

This standard is issued under the fixed designation D93; the number immediately following the designation indicates the year of original adoption or, in the case of revision, the year of last revision. A number in parentheses indicates the year of last reappraisal. A superscript epsilon (ϵ) indicates an editorial change since the last revision or reappraisal.

This standard has been approved for use by agencies of the U.S. Department of Defense.

INTRODUCTION

This flash point test method is a dynamic test method which depends on specified rates of heating to be able to meet the precision of the test method. The rate of heating may not in all cases give the precision quoted in the test method because of the low thermal conductivity of some materials. There are flash point test methods with slower heating rates available, such as Test Method **D3941** (for paints, resins, and related products, and high viscosity products in the range of 0 °C to 110 °C), where the test conditions are closer to equilibrium.

Flash point values are a function of the apparatus design, the condition of the apparatus used, and the operational procedure carried out. Flash point can therefore only be defined in terms of a standard test method, and no general valid correlation can be guaranteed between results obtained by different test methods, or with test apparatus different from that specified.

1. Scope*

1.1 These test methods cover the determination of the flash point of petroleum products in the temperature range from 40 °C to 370 °C by a manual Pensky-Martens closed-cup apparatus or an automated Pensky-Martens closed-cup apparatus, and the determination of the flash point of biodiesel in the temperature range of 60 °C to 190 °C by an automated Pensky-Martens closed cup apparatus.

NOTE 1—Flash point determinations above 250 °C can be performed, however, the precision has not been determined above this temperature. For residual fuels, precision has not been determined for flash points above 100 °C. The precision of in-use lubricating oils has not been determined. Some specifications state a D93 minimum flash point below 40 °C, however, the precision has not been determined below this temperature.

1.2 Procedure A is applicable to distillate fuels (diesel, biodiesel blends, kerosine, heating oil, turbine fuels), new and in-use lubricating oils, and other homogeneous petroleum liquids not included in the scope of Procedure B or Procedure C.

1.3 Procedure B is applicable to residual fuel oils, cutback residua, used lubricating oils, mixtures of petroleum liquids with solids, petroleum liquids that tend to form a surface film under test conditions, or are petroleum liquids of such kinematic viscosity that they are not uniformly heated under the stirring and heating conditions of Procedure A.

1.4 Procedure C is applicable to biodiesel (B100). Since a flash point of residual alcohol in biodiesel is difficult to observe by manual flash point techniques, automated apparatus with electronic flash point detection have been found suitable.

1.5 These test methods are applicable for the detection of contamination of relatively nonvolatile or nonflammable materials with volatile or flammable materials.

1.6 The values stated in SI units are to be regarded as the standard. ~~The values given in parentheses are for information only.~~

NOTE 2—It has been common practice in flash point standards for many decades to alternately use a C-scale or an F-scale thermometer for temperature measurement. Although the scales are close in increments, they are not equivalent. Because the F-scale thermometer used in this procedure is graduated in 5 °F increments, it is not possible to read it to the 2 °C equivalent increment of 3.6 °F. Therefore, for the purposes of application of the procedure of the test method for the separate temperature scale thermometers, different increments must be used. In this test method, the following protocol has been

¹ These test methods are under the joint jurisdiction of ASTM Committee **D02** on Petroleum Products, Liquid Fuels, and Lubricants and are the direct responsibility of Subcommittee **D02.08** on Volatility. In the IP, these test methods are under the jurisdiction of the Standardization Committee.

Current edition approved Oct. 15, 2015; June 1, 2016. Published November 2015/July 2016. Originally approved in 1921. Last previous edition approved in 2015 as **D93—15: D93 – 15a**. DOI: 10.1520/D0093-15A-10.1520/D0093-16.

*A Summary of Changes section appears at the end of this standard

adopted: When a temperature is intended to be a converted equivalent, it will appear in parentheses following the SI unit, for example 370 °C (698 °F). When a temperature is intended to be a rationalized unit for the alternate scale, it will appear after “or,” for example, 2 °C or 5 °F.

1.6.1 *Exception*—The values given in parentheses are for information only.

NOTE 2—It has been common practice in flash point standards for many decades to alternately use a C-scale or an F-scale thermometer for temperature measurement. Although the scales are close in increments, they are not equivalent. Because the F-scale thermometer used in this procedure is graduated in 5 °F increments, it is not possible to read it to the 2 °C equivalent increment of 3.6 °F. Therefore, for the purposes of application of the procedure of the test method for the separate temperature scale thermometers, different increments must be used. In this test method, the following protocol has been adopted: When a temperature is intended to be a converted equivalent, it will appear in parentheses following the SI unit, for example 370 °C (698 °F). When a temperature is intended to be a rationalized unit for the alternate scale, it will appear after “or,” for example, 2 °C or 5 °F.

1.7 *This standard does not purport to address all of the safety concerns, if any, associated with its use. It is the responsibility of the user of this standard to establish appropriate safety and health practices and determine the applicability of regulatory limitations prior to use.* For specific warning statements, see 6.4, 7.1, 9.3, 9.4, 11.1.2, 11.1.4, 11.1.8, 11.2.2, and 12.1.2.

2. Referenced Documents

2.1 ASTM Standards:²

D56 Test Method for Flash Point by Tag Closed Cup Tester

D3941 Test Method for Flash Point by the Equilibrium Method With a Closed-Cup Apparatus

D4057 Practice for Manual Sampling of Petroleum and Petroleum Products

D4177 Practice for Automatic Sampling of Petroleum and Petroleum Products

E1 Specification for ASTM Liquid-in-Glass Thermometers

E300 Practice for Sampling Industrial Chemicals

E502 Test Method for Selection and Use of ASTM Standards for the Determination of Flash Point of Chemicals by Closed Cup Methods

2.2 ISO Standards³

Guide 34 Quality Systems Guidelines for the Production of Reference Materials

Guide 35 Certification of Reference Material—General and Statistical Principles

3. Terminology

3.1 Definitions:

3.1.1 *biodiesel, n*—a fuel comprised of mono-alkyl esters of long chain fatty acids derived from vegetable oils or animal fats, designated B100.

3.1.2 *biodiesel blends, n*—a blend of biodiesel fuel with petroleum-based diesel fuel.

3.1.3 *dynamic, adj—in petroleum products—in petroleum product flash point test methods*—the condition where the vapor above the test specimen and the test specimen are not in temperature equilibrium at the time that the ignition source is applied.

<https://standards.iteh.ai/catalog/standards/sist/13189e47-3a44-4a65-8777-94f18b200cfe/astm-d93-16>

² For referenced ASTM standards, visit the ASTM website, www.astm.org, or contact ASTM Customer Service at service@astm.org. For *Annual Book of ASTM Standards* volume information, refer to the standard’s Document Summary page on the ASTM website.

³ Available from American National Standards Institute (ANSI), 25 W. 43rd St., 4th Floor, New York, NY 10036, <http://www.ansi.org>.

3.1.3.1 Discussion—

This is primarily caused by the heating of the test specimen at the constant prescribed rate with the vapor temperature lagging behind the test specimen temperature.

3.1.4 *equilibrium, n—in petroleum products—in petroleum product flash point test methods*—the condition where the vapor above the test specimen and the test specimen are at the same temperature at the time the ignition source is applied.

3.1.4.1 Discussion—

This condition may not be fully achieved in practice, since the temperature may not be uniform throughout the test specimen, and the test cover and shutter on the apparatus can be cooler.

3.1.5 *flash point, n—in petroleum products, flash point test methods*, the lowest temperature corrected to a barometric pressure of 101.3 kPa (760 mm Hg), of the test specimen, adjusted to account for variations in atmospheric pressure from 101.3 kPa, at which application of an ignition source causes the vapors of a specimen of the test sample to ignite under specified conditions of test.

4. Summary of Test Method

4.1 A brass test cup of specified dimensions, filled to the inside mark with test specimen and fitted with a cover of specified dimensions, is heated and the specimen stirred at specified rates, using one of three defined procedures (A, B, or C). An ignition source is directed into the test cup at regular intervals with simultaneous interruption of the stirring, until a flash is detected (see 11.1.8). The flash point is reported as defined in 3.1.5.

5. Significance and Use

5.1 The flash point temperature is one measure of the tendency of the test specimen to form a flammable mixture with air under controlled laboratory conditions. It is only one of a number of properties which must be considered in assessing the overall flammability hazard of a material.

5.2 Flash point is used in shipping and safety regulations to define *flammable* and *combustible* materials. One should consult the particular regulation involved for precise definitions of these classifications.

5.3 These test methods should be used to measure and describe the properties of materials, products, or assemblies in response to heat and an ignition source under controlled laboratory conditions and should not be used to describe or appraise the fire hazard or fire risk of materials, products, or assemblies under actual fire conditions. However, results of these test methods may be used as elements of a fire risk assessment which takes into account all of the factors which are pertinent to an assessment of the fire hazard of a particular end use.

5.4 These test methods provide the only closed cup flash point test procedures for temperatures up to 370 °C (698 °F).

6. Apparatus

6.1 *Pensky-Martens Closed Cup Apparatus (manual)*—This apparatus consists of the test cup, test cover and shutter, stirring device, heating source, ignition source device, air bath, and top plate described in detail in Annex A1. The assembled manual apparatus, test cup, test cup cover, and test cup assembly are illustrated in Figs. A1.1-A1.4, respectively. Dimensions are listed respectively.

6.2 *Pensky-Martens Closed Cup Apparatus (Automated)*⁴—This apparatus is an automated flash point instrument that is capable of performing the test in accordance with Section 11 (Procedure A), Section 12 (Procedure B), and 13 (Procedure C) of these test methods. The apparatus shall use the test cup, test cover and shutter, stirring device, heating source, and ignition source device described in detail in Annex A1.

6.3 *Temperature Measuring Device*—Thermometer having a range as shown in Table 1 and conforming to the requirements prescribed in Specification E1 or in Annex A3, or an electronic temperature measuring device, such as resistance thermometers or thermocouples. The device shall exhibit the same temperature response as the mercury thermometers.

6.4 *Ignition Source*—Natural gas flame, bottled gas flame, and electric ignitors (hot wire) have been found acceptable for use as the ignition source. The gas flame device described in detailed in Fig. A1.4 requires the use of the pilot flame described in A1.1.2.3. The electric ignitors shall be of the hot-wire type and shall position the heated section of the ignitor in the aperture of the test cover in the same manner as the gas flame device. (**Warning**—Gas pressure supplied to the apparatus should not be allowed to exceed 3 kPa (12 in.) of water pressure.)

6.5 *Barometer*—With accuracy of ±0.5 kPa.

NOTE 3—The barometric pressure used in this calculation is the ambient pressure for the laboratory at the time of the test. Many aneroid barometers, such as those used at weather stations and airports, are precorrected to give sea level readings and would not give the correct reading for this test.

7. Reagents and Materials

7.1 *Cleaning Solvents*—Use suitable solvent capable of cleaning out the specimen from the test cup and drying the test cup and cover. Some commonly used solvents are toluene and acetone. (**Warning**—Toluene, acetone, and many solvents are flammable and a health hazard. Dispose of solvents and waste material in accordance with local regulations.)

⁴ Supporting data regarding a variant of the cover locking mechanism have been filed at ASTM International Headquarters and may be obtained by requesting Research Report RR:D02-1706.

TABLE 1 Temperature Measuring Device

Temperature Range	Thermometer Number	Temperature Range	Thermometer Number
	ASTM		IP
–5 °C to 110 °C (20 °F to 230 °F)	9C (9F)	–5 °C to 110 °C	15C
+10 °C to 200 °C (50 °F to 392 °F)	88C (88F)	+20 °C to 150 °C	101C
+90 °C to 370 °C (200 °F to 700 °F)	10C (10F)	+90 °C to 370 °C	16C

8. Sampling

8.1 Obtain a sample in accordance with instructions given in Practices **D4057**, **D4177**, or **E300**.

8.2 At least 75 mL of sample is required for each test. Refer to Practice **D4057**. When obtaining a sample of residual fuel oil, the sample container shall be from 85 % to 95 % full. For other types of samples, the size of the container shall be chosen such that the container is not more than 85 % full or less than 50 % full prior to any sample aliquot being taken. For biodiesel (B100) samples, a typical one liter container filled to 85 % volume is recommended.

8.3 Successive test specimens can be taken from the same sample container. Repeat tests have been shown to be within the precisions of the method when the second specimen is taken with the sample container at least 50 % filled. The results of flash point determinations can be affected if the sample volume is less than 50 % of sample container capacity.

8.4 Erroneously high flash points may be obtained if precautions are not taken to avoid the loss of volatile material. Do not open containers unnecessarily, to prevent loss of volatile material or possible introduction of moisture, or both. Avoid storage of samples at temperatures in excess of 35 °C or 95 °F. Samples for storage shall be capped tightly with inner seals. Do not make a transfer unless the sample temperature is at least the equivalent of 18 °C or 32 °F below the expected flash point.

8.5 Do not store samples in gas-permeable containers, since volatile material may diffuse through the walls of the enclosure. Samples in leaky containers are suspect and not a source of valid results.

8.6 Samples of very viscous materials shall be heated in their containers, with lid/cap slightly loosened to avoid buildup of dangerous pressure, at the lowest temperature adequate to liquefy any solids, not exceeding 28 °C or 50 °F below the expected flash point, for 30 min. If the sample is then not completely liquefied, extend the heating period for additional 30 min periods as necessary. Then gently agitate the sample to provide mixing, such as orbiting the container horizontally, before transferring to the specimen cup. No sample shall be heated and transferred unless its temperature is more than 18 °C or 32 °F below its expected flash point. When the sample has been heated above this temperature, allow the sample to cool until its temperature is at least 18 °C or 32 °F below the expected flash point before transferring.

NOTE 4—Volatile vapors can escape during heating when the sample container is not properly sealed.

NOTE 5—Some viscous samples may not completely liquefy even after prolonged periods of heating. Care should be exercised when increasing the heating temperature to avoid unnecessary loss of volatile vapors, or heating the sample too close to the flash point.

8.7 Samples containing dissolved or free water may be dehydrated with calcium chloride or by filtering through a qualitative filter paper or a loose plug of dry absorbent cotton. Warming the sample is permitted, but it shall not be heated for prolonged periods or greater than a temperature of 18 °C or 32 °F below its expected flash point.

NOTE 6—If the sample is suspected of containing volatile contaminants, the treatment described in **8.6** and **8.7** should be omitted.

9. Preparation of Apparatus

9.1 Support the manual or automated apparatus on a level steady surface, such as a table.

9.2 Tests are to be performed in a draft-free room or compartment. Tests made in a laboratory hood or in any location where drafts occur are not reliable.

NOTE 7—A shield, of the approximate dimensions 460 mm (18 in.) square and 610 mm (24 in.) high, or other suitable dimensions, and having an open front is recommended to prevent drafts from disturbing the vapors above the test cup.

NOTE 8—With some samples whose vapors or products of pyrolysis are objectionable, it is permissible to place the apparatus along with a draft shield in a ventilation hood, the draft of which is adjustable so that vapors can be withdrawn without causing air currents over the test cup during the ignition source application period.

9.3 Prepare the manual apparatus or the automated apparatus for operation in accordance with the manufacturer's instructions for calibrating, checking, and operating the equipment. (**Warning**—Gas pressure should not be allowed to exceed 3 kPa (12 in.) of water pressure.)

9.4 Thoroughly clean and dry all parts of the test cup and its accessories before starting the test, to ensure the removal of any solvent which had been used to clean the apparatus. Use suitable solvent capable of removing all of the specimen from the test cup and drying the test cup and cover. Some commonly used solvents are toluene and acetone. (**Warning**—Toluene, acetone, and many solvents are flammable. Health hazard. Dispose of solvents and waste material in accordance with local regulations.)

10. Verification of Apparatus

10.1 Adjust the automated flash point detection system (when used) in accordance with the manufacturer's instructions.

10.2 Verify that the temperature measuring device is in accordance with **6.3**.

10.3 Verify the performance of the manual apparatus or the automated apparatus at least once per year by determining the flash point of a certified reference material (CRM) such as those listed in **Annex A4**, which is reasonably close to the expected temperature range of the samples to be tested. The material shall be tested according to Procedure A of these test methods and the

observed flash point obtained in 11.1.8 or 11.2.2 shall be corrected for barometric pressure (see Section 14). The flash point obtained shall be within the limits stated in Table A4.1 for the identified CRM or within the limits calculated for an unlisted CRM (see Annex A4).

10.4 Once the performance of the apparatus has been verified, the flash point of secondary working standards (SWSs) can be determined along with their control limits. These secondary materials can then be utilized for more frequent performance checks (see Annex A4).

10.5 When the flash point obtained is not within the limits stated in 10.3 or 10.4, check the condition and operation of the apparatus to ensure conformity with the details listed in Annex A1, especially with regard to tightness of the lid (A1.1.2.2), the action of the shutter, the position of the ignition source (A1.1.2.3), and the angle and position of the temperature measuring device (A1.1.2.4). After any adjustment, repeat the test in 10.3 using a fresh test specimen, with special attention to the procedural details prescribed in these test methods.

10.6 The numerical values obtained during the verification check (10.3) shall not be used to provide a bias statement, nor shall they be used to make any correction to the flash points subsequently determined using the apparatus.

PROCEDURE A

11. Procedure

11.1 Manual Apparatus:

11.1.1 Ensure that the sample container is filled to the volume capacity requirement specified in 8.2. Fill the test cup with the test specimen to the filling mark inside of the test cup. The temperature of the test cup and test specimen shall be at least 18 °C or 32 °F below the expected flash point. If too much test specimen has been added to the test cup, remove the excess using a syringe or similar device for withdrawal of fluid. Place the test cover on the test cup and place the assembly into the apparatus. Be sure the locating or locking device is properly engaged. If the temperature measuring device is not already in place, insert the device into its holder.

11.1.2 Light the test flame, and adjust it to a diameter of 3.2 mm to 4.8 mm (0.126 in. to 0.189 in.), or switch on the electric igniter and adjust the intensity in accordance with the manufacturer's instructions. (**Warning**—Gas pressure should not be allowed to exceed 3 kPa (12 in.) of water pressure.) (**Warning**—Exercise care when using a gas test flame. If it should be extinguished it will not ignite the vapors in the test cup, and the gas for the test flame that then enters the vapor space can influence the result.) (**Warning**—The operator should exercise and take appropriate safety precautions during the initial application of the ignition source, since test specimens containing low-flash material can give an abnormally strong flash when the ignition source is first applied.) (**Warning**—The operator should exercise and take appropriate safety precautions during the performance of these test methods. The temperatures attained during these test methods, up to 370 °C (698 °F), are considered hazardous.) (**Warning**—As a safety practice, when using automated or manual apparatus, it is strongly advised, before heating the test cup and specimen, to dip the ignitor to check for the presence of unexpected volatile material.)

11.1.3 Apply the heat at such a rate that the temperature, as indicated by the temperature measuring device, increases 5 °C to 6 °C (9 °F to 11 °F)/min.

11.1.4 Turn the stirring device at 90 r/min to 120 r/min, stirring in a downward direction. (**Warning**—Meticulous attention to all details relating to the ignition source, size of test flame or intensity of the electric ignitor, rate of temperature increase, and rate of dipping the ignition source into the vapor of the test specimen is desirable for good results.)

11.1.5 Application of Ignition Source:

11.1.5.1 If the test specimen is expected to have a flash point of 110 °C or 230 °F or below, apply the ignition source when the temperature of the test specimen is 23 °C ± 5 °C or 41 °F ± 9 °F below the expected flash point and each time thereafter at a temperature reading that is a multiple of 1 °C or 2 °F. Discontinue the stirring of the test specimen and apply the ignition source by operating the mechanism on the test cover which controls the shutter so that the ignition source is lowered into the vapor space of the test cup in 0.5 s, left in its lowered position for 1 s, and quickly raised to its upward position.

11.1.5.2 If the test specimen is expected to have a flash point above 110 °C or 230 °F, apply the ignition source in the manner described in 11.1.5.1 at each temperature increase of 2 °C or 5 °F, beginning at a temperature of 23 °C ± 5 °C or 41 °F ± 9 °F below the expected flash point. (**Warning**—As a safety practice, when using automated or manual apparatus, it is strongly advised that, for an expected flash point above 130 °C, to dip the ignitor every 10 °C throughout the test until the sample temperature reaches 28 °C below the expected flash point and then follow the prescribed dipping procedure. This practice has been shown to reduce the possibility of a fire, and, on average, not to significantly affect the result. A limited study⁵ has shown that this dipping practice has no observable effect on test method repeatability.)

11.1.6 When testing materials to determine if volatile material contamination is present, it is not necessary to adhere to the temperature limits for initial ignition source application as stated in 11.1.5.

⁵ Supporting data have been filed at ASTM International Headquarters and may be obtained by requesting Research Report RR:D02-1652.

11.1.7 When testing materials where the expected flash point temperature is not known, bring the material to be tested and the tester to a temperature of $15\text{ }^{\circ}\text{C} \pm 5\text{ }^{\circ}\text{C}$ or $60\text{ }^{\circ}\text{F} \pm 10\text{ }^{\circ}\text{F}$. When the material is known to be very viscous at this temperature, heat the specimen to a starting temperature as described in 8.6. Apply the ignition source, in the manner described in 11.1.5.1, beginning at least $5\text{ }^{\circ}\text{C}$ or $10\text{ }^{\circ}\text{F}$ higher than the starting temperature.

NOTE 9—Flash Point results determined in an “unknown expected flash point mode” should be considered approximate. This value can be used as the expected flash point when a fresh specimen is tested in the standard mode of operation.

11.1.8 Record as the observed flash point the reading on the temperature measuring device at the time ignition source application causes a distinct flash in the interior of the test cup. The sample is deemed to have flashed when a large flame appears and instantaneously propagates itself over the entire surface of the test specimen. (**Warning**—For certain mixtures containing halogenated hydrocarbons, such as, methylene chloride or trichloroethylene, no distinct flash, as defined, is observed. Instead a significant enlargement of the test flame (not halo effect) and change in color of the test flame from blue to yellowish-orange occurs. Continued heating and testing of these samples above ambient temperature can result in significant burning of vapors outside the test cup, and can be a potential fire hazard. See Appendix X1 and Appendix X2 for more information.)

11.1.9 When the ignition source is a test flame, the application of the test flame can cause a blue halo or an enlarged flame prior to the actual flash point. This is not a flash and shall be ignored.

11.1.10 When a flash point is detected on the first application, the test shall be discontinued, the result discarded, and the test repeated with a fresh test specimen. The first application of the ignition source with the fresh test specimen shall be $23\text{ }^{\circ}\text{C} \pm 5\text{ }^{\circ}\text{C}$ or $41\text{ }^{\circ}\text{F} \pm 9\text{ }^{\circ}\text{F}$ below the temperature at which a flash point was detected on the first application.

11.1.11 When a flash point is detected at a temperature which is greater than $28\text{ }^{\circ}\text{C}$ or $50\text{ }^{\circ}\text{F}$ above the temperature of the first application of the ignition source, or when a flash point is detected at a temperature which is less than $18\text{ }^{\circ}\text{C}$ or $32\text{ }^{\circ}\text{F}$ above the temperature of the first application of the ignition source, the result shall be considered approximate, and the test repeated with a fresh test specimen. Adjust the expected flash point for this next test to the temperature of the approximate result. The first application of the ignition source with the fresh test specimen shall be $23\text{ }^{\circ}\text{C} \pm 5\text{ }^{\circ}\text{C}$ or $41\text{ }^{\circ}\text{F} \pm 9\text{ }^{\circ}\text{F}$ below the temperature at which the approximate result was found.

11.1.12 When the apparatus has cooled down to a safe handling temperature, less than $55\text{ }^{\circ}\text{C}$ ($130\text{ }^{\circ}\text{F}$), remove the test cover and the test cup and clean the apparatus as recommended by the manufacturer.

NOTE 10—Exercise care when cleaning and positioning the lid assembly so not to damage or dislocate the flash detection system or temperature measuring device. See the manufacturer’s instructions for proper care and maintenance.

11.2 Automated Apparatus:

11.2.1 The automated apparatus shall be capable of performing the procedure as described in 11.1, including control of the heating rate, stirring of the test specimen, application of the ignition source, detection of the flash point, and recording the flash point.

11.2.2 Start the automated apparatus in accordance with the manufacturer’s instructions. (**Warning**—Failure to install the sample temperature measuring device correctly, when using automated apparatus, can result in uncontrolled heating of the test portion and potentially a fire. Some automated apparatus include provisions to avoid this occurrence.) The apparatus shall follow the procedural details described in 11.1.3 through 11.1.8.

PROCEDURE B

12. Procedure

12.1 Manual Apparatus:

12.1.1 Ensure that the sample container is filled to the volume capacity requirement specified in 8.2. Fill the test cup with the test specimen to the filling mark inside of the test cup. The temperature of the test cup and test specimen shall be at least $18\text{ }^{\circ}\text{C}$ or $32\text{ }^{\circ}\text{F}$ below the expected flash point. If too much test specimen has been added to the test cup, remove the excess using a syringe or similar device for withdrawal of fluid. Place the test cover on the test cup and place the assembly into the apparatus. Be sure the locating or locking device is properly engaged. If the temperature measuring device is not already in place, insert the device into its holder.

12.1.2 Light the test flame and adjust it to a diameter of 3.2 mm to 4.8 mm (0.126 in. to 0.189 in.), or switch on the electric igniter and adjust the intensity in accordance with the manufacturer’s instructions. (**Warning**—Gas pressure should not be allowed to exceed 3 kPa (12 in.) of water pressure.) (**Warning**—Exercise care when using a gas test flame. If it should be extinguished it will not ignite the vapors in the test cup and the gas for the test flame that then enters the vapor space can influence the result.) (**Warning**—The operator should exercise and take appropriate safety precautions during the initial application of the ignition source, since test specimens containing low-flash material may give an abnormally strong flash when the ignition source is first applied.) (**Warning**—The operator should exercise and take appropriate safety precautions during the performance of these test methods. The temperatures attained during these test methods, up to $370\text{ }^{\circ}\text{C}$ ($698\text{ }^{\circ}\text{F}$), are considered hazardous.)

12.1.3 Turn the stirring device at $250\text{ r/min} \pm 10\text{ r/min}$, stirring in a downward direction.

12.1.4 Apply the heat at such a rate that the temperature as indicated by the temperature measuring device increases $1\text{ }^{\circ}\text{C}$ to $1.6\text{ }^{\circ}\text{C}$ ($2\text{ }^{\circ}\text{F}$ to $3\text{ }^{\circ}\text{F}$)/min.

12.1.5 Proceed as prescribed in Section 11, with the exception of the preceding requirements for rates of stirring and heating.

12.2 *Automated Apparatus:*

12.2.1 The automated apparatus shall be capable of performing the procedure as described in 12.1, including control of the heating rate, stirring of the test specimen, application of the ignition source, detection of the flash point, and recording the flash point.

12.2.2 Start the automated apparatus in accordance with the manufacturer's instructions. The apparatus shall follow the procedural details in accordance with 12.1.3 through 12.1.5.

Procedure C

13. Procedure

13.1 *Automated Apparatus*—Ensure that the apparatus is equipped with an electronic measuring system for the detection of the flash point.

13.2 Ensure that the sample container is filled to the volume capacity requirement specified in 8.2. Fill the test cup with the test specimen to the filling mark inside of the test cup. The temperature of the test cup and test specimen shall be at least 24 °C below the expected flash point. If too much test specimen has been added to the test cup, remove the excess using a syringe or similar device for withdrawal of fluid. Place the test cover on the test cup and place the assembly into the apparatus. Be sure the locating or locking device is properly engaged. If the temperature measuring device is not already in place, insert the device into its holder.

13.3 Light the test flame, and adjust it to a diameter of 3.2 mm to 4.8 mm (0.126 in. to 0.189 in.) or switch on the electric igniter and adjust the intensity in accordance with the manufacturer's instructions. (**Warning**—Gas pressure should not be allowed to exceed 3 kPa (12 in. of water pressure.) (**Warning**—Exercise care when using a gas test flame. If it should be extinguished it will not ignite the vapors in the test cup, and the gas for the test flame that then enters the vapor space can influence the result.) (**Warning**—The operator should exercise and take appropriate safety precautions during the initial application of the ignition source, since test specimens containing low-flash material can give an abnormally strong flash when the ignition source is first applied.) (**Warning**—The operator should exercise and take appropriate safety precautions during the performance of these test methods. The temperatures attained during these test methods, up to 370 °C (698 °F), are considered hazardous.)

13.4 Apply the heat at such a rate that the temperature as indicated by the temperature measuring device increases 3.0 °C/min ± 0.5 °C/min.

13.5 Turn the stirring device at 90 r/min to 120 r/min, stirring in a downward direction. (**Warning**—Meticulous attention to all details relating to the ignition source, size of test flame, rate of temperature increase, and rate of dipping the ignition source into the vapor of the test specimen is desirable for good results.)

13.6 *Application of Ignition Source*—The first test on the sample shall use an expected flash point of 100 °C.

13.7 Apply the ignition source when the temperature of the test specimen is approximately 24 °C below the expected flash point and each time thereafter at a temperature reading that is a multiple of 2 °C. Discontinue the stirring of the test specimen and apply the ignition source by operating the mechanism on the test cover which controls the shutter so that the ignition source is lowered into the vapor space of the test cup in 0.5 s, left in its lowered position for 1 s, and quickly raised to its upward position.

13.8 Record as the flash point the reading on the temperature measuring device at the time the ignition source application causes a distinct flash in the interior of the test cup which is detected by the electronic device.

13.9 The application of the test flame can cause a blue halo or an enlarged flame prior to the actual flash point. This is not a flash and shall be ignored.

13.10 When a flash point is detected on the first application, the test shall be discontinued, the result discarded, and the test repeated with a fresh test specimen. The first application of the ignition source with the fresh test specimen shall be approximately 24 °C below the temperature at which a flash point was detected on the first application.

13.11 When a flash point is detected at a temperature which is greater than 30 °C above the temperature of the first application of the ignition source, or when a flash point is detected at a temperature which is less than 16 °C above the temperature of the first application of the ignition source, the result shall be considered approximate, and the test repeated with a fresh test specimen. Adjust the expected flash point for this next test to the temperature of the approximate result. The first application of the ignition source with the fresh test specimen shall be approximately 24 °C below the temperature at which the approximate result was found.

13.12 When the apparatus has cooled down to a safe handling temperature, less than 55 °C, remove the test cover and the test cup and clean the apparatus as recommended by the manufacturer.

NOTE 11—Exercise care when cleaning and positioning the lid assembly so not to damage or dislocate the flash detection system or temperature measuring device. See the manufacturer's instructions for proper care and maintenance.

PRECISION, CALCULATION, AND REPORT FOR PROCEDURES A, B, OR C

14. Calculation

14.1 Observe and record the ambient barometric pressure (see **Note 3**) at the time of the test. When the pressure differs from 101.3 kPa (760 mm Hg), correct the flash point as follows:

$$\text{Corrected flash point} = C + 0.25 (101.3 - K) \quad (1)$$

$$\text{Corrected flash point} = F + 0.06 (760 - P) \quad (2)$$

$$\text{Corrected flash point} = C + 0.033 (760 - P) \quad (3)$$

where:

C = observed flash point, °C,

F = observed flash point, °F,

P = ambient barometric pressure, mm Hg, and

K = ambient barometric pressure, kPa.

14.2 After correction for barometric pressure, round the temperature to the nearest 0.5 °C (1 °F) and record.

15. Report

15.1 Report the corrected flash point as the ASTM D93, Procedure A or Procedure B or Procedure C Pensky-Martens Closed Cup Flash Point of the test specimen.

16. Precision and Bias (Procedure A)

16.1 *Precision*—The precision of this procedure as determined by the statistical examination of the interlaboratory test results, is as follows:

16.1.1 *Repeatability*—The difference between successive results, obtained by the same operator with the same apparatus under constant operating conditions on identical test material, would in the long run, in the normal and correct operation of the test method, exceed the following values in 1 case in 20.

$$r = AX, \quad (4)$$

$$A = 0.029,$$

X = mean result in °C, and

r = repeatability.⁶

16.1.2 *Reproducibility*—The difference between two single and independent results, obtained by different operators working in different laboratories on identical material, would in the long run, in the normal and correct operation of the test method, exceed the following values only in 1 case in 20.

$$R = BX, \quad (5)$$

$$B = 0.071,$$

X = mean result in °C, and

R = reproducibility.

16.1.3 *Bias*—Since there is no accepted reference material suitable for determining the bias for the procedure in these test methods, bias has not been determined.

16.1.4 *Relative Bias*—Statistical evaluation of the data did not detect any significant difference between the reproducibility variances of manual and automated Pensky-Martens flash point results for the samples studied. Evaluation of the data did not detect any significant difference between averages of manual and automated Pensky-Martens flash point for the samples studied with the exception of cycle oil and fuel oil which showed some bias. In any case of dispute, the manual procedure shall be considered the referee test.

NOTE 12—The precision statements were derived on clear liquids only. Refer to the research report⁶ for information regarding relative bias and types of samples. Additional studies are in progress concerning relative bias.

16.1.5 The precision data were developed from a combined 1991 ASTM cooperative test program⁶ using 5 samples of fuel and lubricating oils (Twelve laboratories participated with the manual apparatus and 21 laboratories participated with the automated

⁶ Supporting data (the results of the 1991 interlaboratory cooperative test program) have been filed at ASTM International Headquarters and may be obtained by requesting Research Report RR:S15-1008.

equipment) and a 1994 IP cooperative test program using 12 fuel samples and 4 pure chemicals. (Twenty-six laboratories participated with manual and automated equipment. The apparatus used either a gas test flame or an electric resistance (hot wire) device for the ignition source. Information on the type of samples and their average flash point are in the research report.⁶

17. Precision and Bias (Procedure B)

17.1 *Precision*—The precision of this procedure, as determined by the statistical examination of the interlaboratory test results, is as follows:

17.1.1 *Repeatability*—The difference between successive results obtained by the same operator with the same apparatus under constant operating conditions on identical test materials would, in the long run, in the normal and correct operation of the test method, exceed the following value in 1 case in 20:

Residual fuel oil 2 °C
Other types 5 °C

17.1.2 *Reproducibility*—The difference between two single and independent results obtained by different operators working in different laboratories on identical material would, in the long run, exceed the following value only in 1 case in 20:

Residual fuel oil 6 °C
Other types 10 °C

NOTE 13—The precisions of these standards were derived from interlaboratory studies conducted in degrees Celsius.

17.1.3 *Bias*—Since there is no accepted reference material suitable for determining the bias for the procedure in these test methods, bias has not been determined.

17.1.4 The precision data for residual fuel oils were developed in a 1996 cooperative test program conducted by the IP using 12 samples of residual fuel and 40 laboratories worldwide using both the manual and automated apparatus. Information on the type of samples and their average flash point are in the research report.

17.1.5 The precision data for other sample types in Procedure B is not known to have been developed in accordance with RR:D02-1007.

NOTE 14—Procedure B was not tested in the 1991 interlaboratory program.

18. Precision and Bias (Procedure C)⁷

18.1 *Precision*—The precision of this procedure, as determined by the statistical examination of the interlaboratory test results, is as follows:

18.1.1 *Repeatability*—The difference between successive results obtained by the same operator with the same apparatus under constant operating conditions on identical test materials would, in the long run, in the normal and correct operation of the test method, exceed the following value in 1 case in 20:

8.4 °C

18.1.2 *Reproducibility*—The difference between two single and independent results obtained by different operators working in different laboratories on identical material would, in the long run, in the normal and correct operation of the test method, exceed the following value only in 1 case in 20:

14.7 °C

NOTE 15—The precisions of these standards were derived from interlaboratory studies conducted in degrees Celsius.

18.1.3 *Bias*—Since there is no accepted reference material suitable for determining the bias for the procedure in these test methods, bias has not been determined.

18.1.4 The precision data for biodiesel were developed in a 2008 cooperative interlaboratory test program⁷ using 9 samples of biodiesel (B100) of various source and 17 samples of the same biodiesel dosed with concentrations of alcohol from 0.1 % to 0.3 %. Various automated apparatus in 11 laboratories participated. The precision was calculated on the flash point range from 60 °C to 190 °C. The alcohol concentrations were verified in separate laboratories using EN 14110. Information on the type of samples and their average flash point are in the research report.

19. Keywords

19.1 automated flash point; automated Pensky-Martens closed cup; flammability; flash point; Pensky-Martens closed cup

⁷ Supporting data (the results of the 2008 interlaboratory cooperative test program) have been filed at ASTM International Headquarters and may be obtained by requesting Research Report RR:D02-1683.

ANNEXES

(Mandatory Information)

A1. APPARATUS SPECIFICATIONS⁴

A1.1 A typical assembly of the apparatus, gas heated, is shown in Fig. A1.1. The apparatus shall consist of a test cup, cover, and stove conforming to the following requirements:

A1.1.1 *Cup*—The cup shall be of brass, or other nonrusting metal of equivalent heat conductivity, and shall conform to the

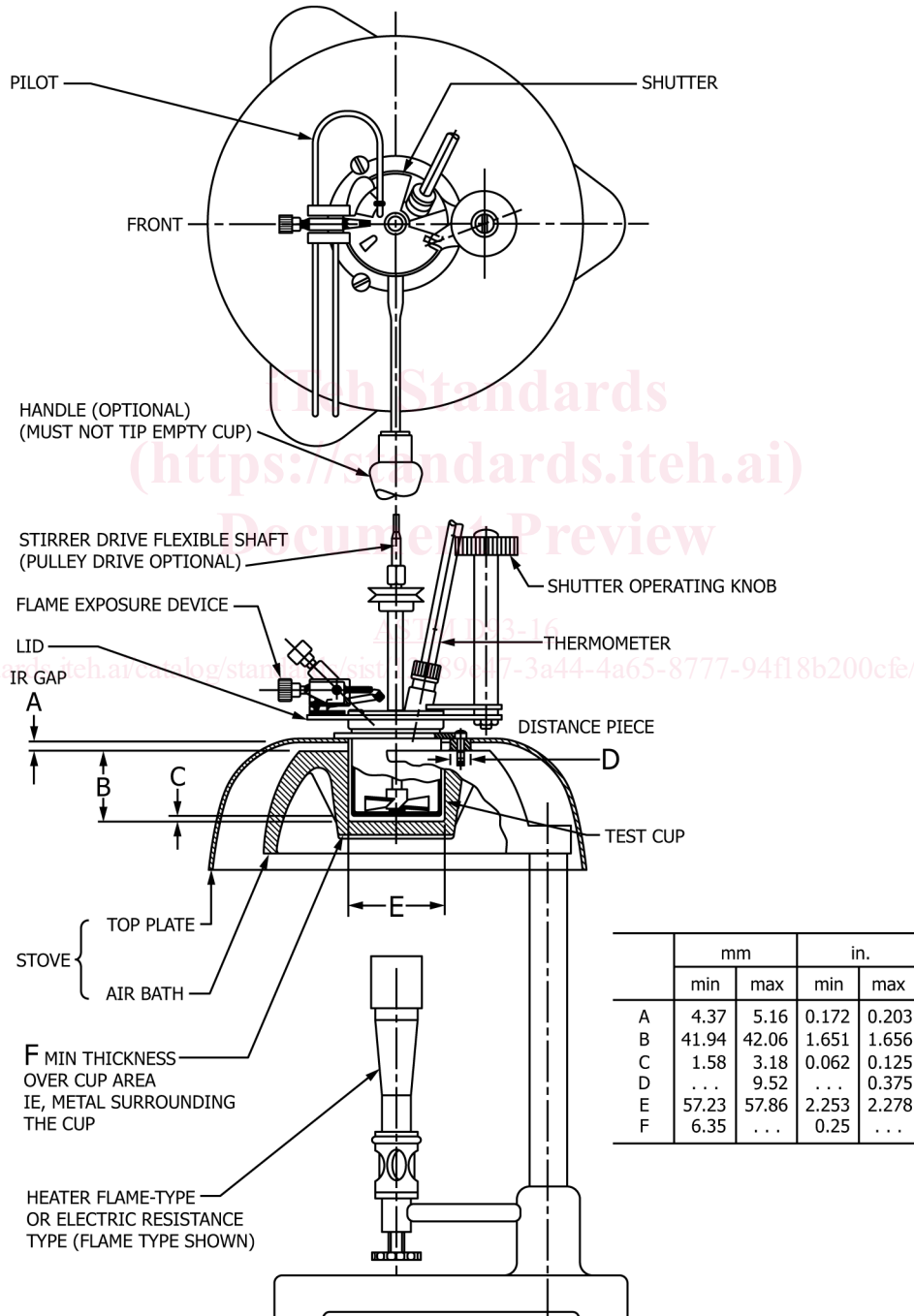

NOTE 1—Lid assembly can be positioned either right or left-handed.

FIG. A1.1 Pensky-Martens Closed Flash Tester