



Designation: D3828 – 16

Standard Test Methods for Flash Point by Small Scale Closed Cup Tester¹

This standard is issued under the fixed designation D3828; the number immediately following the designation indicates the year of original adoption or, in the case of revision, the year of last revision. A number in parentheses indicates the year of last reapproval. A superscript epsilon (ϵ) indicates an editorial change since the last revision or reapproval.

This standard has been approved for use by agencies of the U.S. Department of Defense.

INTRODUCTION

These small scale flash point methods are generally used for testing a sample at a specific temperature where the specimen being tested and the air–vapor mixture above it are close to thermal equilibrium. Test Method D3941 covers other flash point equipment operated at a specific temperature.

Flash point values are a function of the apparatus design, the condition of the apparatus used, and the operational procedure carried out. Flash point can therefore only be defined in terms of a standard test method, and no general valid correlation can be guaranteed between results obtained by different test methods, or with test apparatus different from that specified.

1. Scope*

1.1 These test methods cover procedures for flash point tests, within the range of $-30\text{ }^{\circ}\text{C}$ to $300\text{ }^{\circ}\text{C}$, of petroleum products and biodiesel liquid fuels, using a small scale closed cup tester. The procedures may be used to determine, whether a product will or will not flash at a specified temperature (flash/no flash Method A) or the flash point of a sample (Method B). When used in conjunction with an electronic thermal flash detector, these test methods are also suitable for flash point tests on biodiesels such as fatty acid methyl esters (FAME).

1.2 The values stated in SI units are to be regarded as the standard. The values given in parentheses are for information only.

1.3 *This standard should be used to measure and describe the properties of materials, products, or assemblies in response to heat and flame under controlled laboratory conditions and should not be used to describe or appraise the fire hazard or fire risk of materials, products, or assemblies under actual fire conditions. However, results of this test may be used as elements of a fire risk assessment which takes into account all of the factors which are pertinent to an assessment of the fire hazard of a particular end use.*

1.4 *This standard does not purport to address all of the safety concerns, if any, associated with its use. It is the*

responsibility of the user of this standard to establish appropriate safety and health practices and determine the applicability of regulatory limitations prior to use. Warning statements appear throughout. See also the Material Safety Data Sheets for the product being tested.

2. Referenced Documents

2.1 ASTM Standards:²

D3941 Test Method for Flash Point by the Equilibrium Method With a Closed-Cup Apparatus

D4057 Practice for Manual Sampling of Petroleum and Petroleum Products

D4177 Practice for Automatic Sampling of Petroleum and Petroleum Products

D6299 Practice for Applying Statistical Quality Assurance and Control Charting Techniques to Evaluate Analytical Measurement System Performance

D6708 Practice for Statistical Assessment and Improvement of Expected Agreement Between Two Test Methods that Purport to Measure the Same Property of a Material

E300 Practice for Sampling Industrial Chemicals

E1137/E1137M Specification for Industrial Platinum Resistance Thermometers

2.2 ISO Standards:³

Guide 34 Quality Systems Guidelines for the Production of Reference Materials

¹ These test methods are under the jurisdiction of ASTM Committee D02 on Petroleum Products, Liquid Fuels, and Lubricants and is the direct responsibility of Subcommittee D02.08 on Volatility.

Current edition approved June 1, 2016. Published July 2016. Originally approved in 1979. Last previous edition approved in 2012 as D3828 – 12a. DOI: 10.1520/D3828-16.

² For referenced ASTM standards, visit the ASTM website, www.astm.org, or contact ASTM Customer Service at service@astm.org. For *Annual Book of ASTM Standards* volume information, refer to the standard's Document Summary page on the ASTM website.

³ Available from American National Standards Institute (ANSI), 25 W. 43rd St., 4th Floor, New York, NY 10036, <http://www.ansi.org>.

*A Summary of Changes section appears at the end of this standard

Guide 35 Certification of Reference Materials—General and Statistical Principles

EN ISO 3679 Determination of Flash Point—Rapid Equilibrium Closed Cup Method

EN ISO 3680 Determination of Flash/No Flash—Rapid Equilibrium Closed Cup Method

ISO 60751 Industrial Platinum Resistance Thermometers and Platinum Temperature Sensors

2.3 *Energy Institute Standards*.⁴

IP 523 Determination of Flash Point—Rapid Equilibrium Closed Cup Method

IP 524 Determination of Flash/No Flash—Rapid Equilibrium Closed Cup Method

3. Terminology

3.1 Definitions:

3.1.1 *equilibrium, n—in flash point test methods*, the condition where the vapor above the test specimen, and the test specimen are at the same temperature at the time the ignition source is applied.

3.1.1.1 *Discussion*—This condition may not be fully achieved in practice, since the temperature may not be uniform throughout the test specimen, and the test cover and shutter on the apparatus can be cooler or warmer.

3.1.2 *flash point, n—in flash point test methods*, the lowest temperature of the test specimen, adjusted to account for variations in atmospheric pressure from 101.3 kPa, at which application of an ignition source causes the vapors of the test specimen to ignite under specified conditions of test.

4. Summary of Test Methods

4.1 *Method A—Flash/No Flash Test*—A test specimen is introduced, by a syringe, into the test cup of the selected apparatus that is set and maintained at the specified temperature. After a specific time an ignition source is applied and a determination made as to whether or not a flash occurred.

4.2 *Method B—Finite (or Actual) Flash Point*—This method essentially repeats Method A a number of times, and by changing the test temperature and test specimen a number of times, determines the flash point.

4.2.1 A test specimen is introduced into the test cup of the selected apparatus that is maintained at the expected flash point. After a specified time an ignition source is applied and a determination made whether or not a flash occurred.

4.2.2 The test specimen is removed from the test cup; the test cup and cover are cleaned, and the test temperature adjusted 5 °C (9 °F) lower or higher depending on whether or not a flash occurred previously. A fresh test specimen is introduced and tested. This procedure is repeated until the flash point is established within 5 °C (9 °F).

4.2.3 The procedure is then repeated at 1 °C (2 °F) intervals until the flash point is determined to the nearest 1 °C (2 °F).

4.2.4 If improved accuracy is desired the procedure is repeated at 0.5 °C (1 °F) intervals until the flash point is determined to the nearest 0.5 °C (1 °F).

4.3 Test Time and Specimen Volume:

4.3.1 For all products, except biodiesel; for test temperatures up to and including 100 °C (212 °F), the test time is 1 min and the specimen volume is 2 mL.

4.3.2 For all products, except biodiesel; for test temperatures over 100 °C (212 °F), the test time is 2 min and the specimen volume is 4 mL.

4.3.3 For biodiesel; for all test temperatures, the test time is 1 min and the specimen volume is 2 mL.

5. Significance and Use

5.1 Flash point measures the response of the test specimen to heat and ignition source under controlled laboratory conditions. It is only one of a number of properties that must be considered in assessing the overall flammability hazard of a material.

5.2 Flash point is used in shipping and safety regulations to define *flammable* and *combustible* materials and classify them. Consult the particular regulation involved for precise definitions of these classes.

5.3 Flash point can indicate the possible presence of highly volatile and flammable materials in a relatively nonvolatile or nonflammable material.

5.4 These test methods use a smaller sample (2 mL to 4 mL) and a shorter test time (1 min to 2 min) than traditional test methods.

5.5 Method A, IP 524 and EN ISO 3680 are similar methods for flash no-flash tests. Method B, IP 523 and EN ISO 3679 are similar methods for flash point determination.

6. Apparatus

6.1 *Test Cup and Cover Assembly*—The essential dimensions and requirements of the apparatus are shown in **Fig. A1.1** and **Table A1.1** of **Annex A1**. The apparatus and accessories are described in detail in **Annex A1**. The temperature range is from –30 °C to 300 °C. Some versions of the apparatus may not cover the full temperature range.

6.2 *Barometer*; accurate to 0.5 kPa. Barometers that have been pre-corrected for use at weather stations or airports are not suitable.

6.3 *Draft Shield*—A shield located at the back and on two sides of the instrument, for use in circumstances where protection from drafts does not exist.

7. Reagents and Materials

7.1 *Cleaning Solvent*—Use only non-corrosive solvents capable of cleaning the test cup and cover. Two commonly used solvents are toluene and acetone. (**Warning**—Toluene, acetone and many other solvents are flammable and a health hazard. Dispose of solvents and waste material in accordance with local regulations.)

7.2 *Butane, Propane and Natural Gas*—For use as a pilot and ignition source (not required if an electric ignitor is used). (**Warning**—Butane, propane and natural gases are flammable and a health hazard.)

⁴ Available from Energy Institute, 61 New Cavendish St., London, WIG 7AR, U.K., <http://www.energyinst.org.uk>.

8. Sampling

8.1 Obtain at least a 50 mL sample from a bulk test site in accordance with Practices [D4057](#), [D4177](#), [E300](#) or other comparable sampling practices.

8.2 Store samples in clean, tightly sealed containers at normal room temperature (20 °C to 25 °C) or colder.

8.3 Do not store samples for an extended period of time in gas permeable containers, such as those made of plastic, because volatile material can diffuse through the walls of the container. Samples in leaky containers are suspect and not a source of valid results.

8.4 Erroneously high flash points can be obtained when precautions are not taken to avoid loss of volatile materials. Do not open containers unnecessarily. Do not make a transfer unless the sample temperature is at least 10 °C below the expected flash point. Where possible perform the flash point as the first test on the sample.

8.5 Samples containing dissolved or free water may be dehydrated with calcium chloride. (**Warning**—If the sample is expected of containing volatile components, the treatment as described in [8.5](#) should be omitted.)

8.6 Cool, or adjust the temperature of the sample and its container to at least 10 °C below the expected flash point before opening to remove the test specimen. If an aliquot of the original sample is to be stored prior to testing, ensure that the container is filled to between 85 % and 95 % of its capacity.

NOTE 1—Results of flash point tests can be affected if the sample volume falls below 50 % of the container's capacity.

8.7 If sufficiently fluid, mix samples by gently shaking by hand prior to removal of the test specimen, taking care to minimize the loss of volatile components. If the sample is too viscous at ambient temperature, gently warm the sample in its container to a temperature not warmer than 10 °C below the test temperature, such that the sample can be mixed by gentle shaking. Ensure that high pressures do not develop in the container when warming.

8.8 If the sample cannot be made sufficiently fluid to be introduced into the test cup through the orifice by heating in accordance with [8.7](#), transfer the test specimen with a solids dispenser or spatula while the cover is open. The specimen size can be the mass equivalent of the required volume and the specimen should be spread over the bottom of the test cup as evenly as possible. Precision has not been determined for solid samples.

9. Preparation of Apparatus

9.1 Place the apparatus on a level, stable surface. Unless tests are made in a draft-free area, surround the tester on three sides with a draft shield (see [6.3](#)) for protection. Do not rely on tests made in a laboratory draft hood unless the extracted air and vapors can be withdrawn without causing air currents over the test cup during the ignition source application period.

9.2 Read the manufacturer's instructions on the care and servicing of the instrument and for the correct operation of any controls.

9.3 Prepare the apparatus for operation in accordance with the manufacturers' instructions for calibrating, checking and operating the equipment, especially the operation of the ignition source. (**Warning**—An incorrectly set test flame size or setting of an electric ignitor can significantly affect the test result.)

9.4 Clean the test cup, cover and its accessories with an appropriate solvent ([7.1](#)) to remove any traces of gum or residue from the previous test. Wipe dry with absorbent paper. A stream of dry clean air may be used to remove the last traces of solvent used. A pipe cleaner may be used to clean the filler orifice.

9.5 Measure and record the barometric pressure ([6.2](#)) before commencing a test.

9.6 Use an electronic thermal flash detector for flash point tests on biodiesels such as fatty acid methyl esters (FAME) (see [A1.7](#)). The flash detector may be used for other test materials.

9.7 For sub-ambient test temperatures see [Annex A4](#), unless the apparatus has integral test cup cooling facilities.

10. Verification of Apparatus

10.1 Verify and correct, if necessary, the readings on the temperature measuring device at least every 12 months, according to the manufacturer's instructions and that the temperature measuring device is in accordance with [A1.2.2](#) and [Annex A5](#).

10.2 Verify the performance of the apparatus at least once per year by determining the flash point of a certified reference material (CRM) such as those listed in [Annex A2](#), which is reasonably close to the expected temperature range of the samples to be tested. The material shall be tested according to Method B, Section [12](#) and the detected flash point determined in [12.1.6](#) and [12.1.6.1](#) shall be corrected for barometric pressure (see Section [13](#)). The flash point obtained shall be within the limits stated in [Table A2.1](#) for the identified CRM or within the limits calculated for an unlisted CRM (see [Annex A2](#)).

10.3 Once the performance of the apparatus has been verified, the flash point of secondary working standards (SWS) can be determined along with their control limits. These secondary materials can then be utilized for more frequent performance checks (see [Annex A2](#)).

10.4 When the flash point obtained is not within the limits stated in [10.2](#) or [10.3](#), check the condition and operation of the apparatus to ensure conformity with the details listed in [Annex A1](#), especially with regard to tightness of the cover ([A1.2.1](#)), the action of the shutter, the size or intensity of the ignition source, the position of the ignition source ([A1.3](#)), the operation of the flash detector (if fitted) and correct reading of the

temperature measuring device. After any adjustment, repeat the test in 10.2 or 10.3 using a fresh test specimen, with special attention to the procedural details prescribed in the test method.

METHOD A—FLASH/NO FLASH TEST

11. Procedure

11.1 For specification purposes carry out a flash/no flash test at a temperature (actual) that allows for a correction due to the ambient atmospheric pressure at the time of the test. Use the following equations to convert a specification flash point test requirement to the actual test temperature required for the test and then round to the nearest 0.5 °C (1 °F).

$$\text{Actual test temperature, } ^\circ\text{C} = S_c - 0.25(101.3 - A) \quad (1)$$

$$\text{Actual test temperature, } ^\circ\text{C} = S_c - 0.03(760 - B) \quad (2)$$

$$\text{Actual test temperature, } ^\circ\text{F} = S_f - 0.06(760 - B) \quad (3)$$

where:

S_c = specification, or uncorrected target test temperature, °C,

S_f = specification, or uncorrected target test temperature, °F,

B = ambient barometric pressure, mm Hg, and

A = ambient barometric pressure, kPa.

11.2 Inspect the test cup and cover for cleanliness and correct operation, especially with regard to tightness of the cover (A1.2.1), the action of the shutter, the size or intensity of the ignition source and the position of the ignition source (A1.3). Clean if necessary (9.3). Put the cover in place and close securely.

11.3 Follow the manufacturer's instructions to set the test temperature and the test time, and select the test specimen volume in accordance with Table 1.

11.4 When the test cup is at the test temperature, fill the appropriate syringe (A1.5, A1.6) with the sample to be tested; transfer the syringe to the filling orifice, taking care not to lose any sample; discharge the test specimen into the test cup by fully depressing the syringe plunger; remove the syringe.

11.5 Start the test timer; light the pilot light and adjust the test flame (if used) to conform to the 4 mm ($\frac{5}{32}$ in.) gauge.

11.6 When the end of the test time is indicated, apply the ignition source by slowly and uniformly opening the shutter and closing it completely over a period of 2½ s. Watch closely for a flash at the test cup openings if a flash detector is not used.

11.6.1 The test specimen is deemed to have flashed when a large flame appears and instantaneously propagates itself over the surface of the test specimen (see 3.1.2). Occasionally, particularly near the actual flash point, application of a gas

ignition source can cause a blue halo or an enlarged flame; this is not a flash and should be ignored.

11.7 Record the test result as flash (or no flash) and the test temperature.

11.8 Turn off the pilot and test flames (if used). Remove the test specimen and clean the test cup and cover. It may be necessary to allow the test cup temperature to fall to a safe level before cleaning.

METHOD B—FLASH POINT DETERMINATION

12. Procedure

12.1 This procedure repeats the procedures of Method A (11.3 through 11.8) a number of times. Each test uses a fresh test specimen and a different temperature. The change of temperature allows the determination of two temperatures 1 °C (2 °F) or 0.5 °C (1 °F) apart for which the lower temperature did not result in a flash while the higher temperature resulted in a flash (the flash point).

12.1.1 Select the expected flash point of the sample as the initial test temperature and follow the procedure 11.3 to 11.8.

12.1.2 If a flash is detected, repeat the procedure given in 11.3 to 11.8 testing a fresh specimen at a temperature 5 °C (9 °F) lower each time until no flash is detected.

12.1.2.1 Proceed to 12.1.4.

12.1.3 When no flash was detected, repeat the procedure given in 11.3 to 11.8 testing a fresh specimen at a temperature 5 °C (9 °F) higher each time until a flash is detected.

12.1.4 Having established a flash within two temperatures 5 °C (9 °F) apart, repeat the procedure at 1 °C (2 °F) intervals from the lower of the two temperatures until a flash is detected.

12.1.5 Record the temperature of the test when this flash occurs as the flash point, allowing for any known thermometer correction.

12.1.6 The flash point determined in 12.1.4 will be to the nearest 1 °C (2 °F).

12.1.6.1 If improved accuracy is desired (that is, to the nearest 0.5 °C (1 °F)) test a fresh test specimen at a temperature 0.5 °C (1 °F) below that at which the flash was detected in 12.1.4. If no flash is detected, the temperature recorded in 12.1.4 is the flash point to the nearest 0.5 °C (1 °F). If a flash is detected at the lower temperature (12.1.6), record this latter temperature as the flash point.

12.1.7 Turn off the pilot and test flames, if used. When the cup temperature falls to a safe level, remove the test specimen and clean the cup and cover.

13. Calculation

13.1 *Method A*—No further calculations are required as the effects of barometric pressure were corrected for in Eq 1-3 in 11.1.

13.1.1 If the effects of barometric pressure were not corrected before the flash/no flash test, Eq 4-6 shall be used to calculate the corrected test temperature.

$$\text{Corrected (specification) test temperature (} ^\circ\text{C)} = C + 0.25(101.3 - A) \quad (4)$$

TABLE 1 Test Conditions

Sample	Test Temperatures	Specimen Volume	Test Time
All except biodiesel	≤ 100 °C (212 °F)	2 mL	1 min
All except biodiesel	> 100 °C (212 °F)	4 mL	2 min
Biodiesel	≤ 300 °C (572 °F)	2 mL	1 min

$$\text{Corrected (specification) test temperature (}^\circ\text{F)} = F + 0.06(760 - B) \quad (5)$$

$$\text{Corrected (specification) test temperature (}^\circ\text{C)} = C + 0.03(760 - B) \quad (6)$$

where:

- C = actual test temperature, $^\circ\text{C}$,
- F = actual test temperature, $^\circ\text{F}$,
- A = ambient barometric pressure, kPa, and
- B = ambient barometric pressure, mm Hg.

13.2 *Method B*—If the ambient barometric pressure (9.5) differs from 101.3 kPa (760 mm Hg) correct the flash point as follows:

$$\text{Corrected flash point (}^\circ\text{C)} = C + 0.25(101.3 - A) \quad (7)$$

$$\text{Corrected flash point (}^\circ\text{F)} = F + 0.06(760 - B) \quad (8)$$

$$\text{Corrected flash point (}^\circ\text{C)} = C + 0.03(760 - B) \quad (9)$$

where:

- C = detected flash point, $^\circ\text{C}$,
- F = detected flash point, $^\circ\text{F}$,
- A = ambient barometric pressure, kPa, and
- B = ambient barometric pressure, mm Hg.

14. Report

14.1 Method A (flash/no flash), report flash (or no flash) at the specification (corrected) temperature (report temperature) rounded to the nearest 0.5 $^\circ\text{C}$ (1 $^\circ\text{F}$), and that Method A was used.

14.2 Method B (flash point determination), report the corrected flash point rounded to the nearest 0.5 $^\circ\text{C}$ (1 $^\circ\text{F}$), and that Method B was used.

14.3 Report the identification of the material tested, the test date and any deviation, by agreement or not, from the procedures specified.

15. Precision and Bias⁵

15.1 *Precision*—The precision for Procedure B of this test method for petroleum and related products as determined by statistical examination of interlaboratory results is given in 15.1.1, 15.1.2, and Table 2. See Annex A3 for precision of fatty acid methyl esters (FAME).

15.1.1 *Repeatability*—The difference between the two test results, obtained by the same operator with the same apparatus

under constant operating conditions on identical test material, would, in the long run, in the normal and correct operation of this test method, exceed the following values only in 1 case in 20. For examples of precision, see Table 2; valid range 20 $^\circ\text{C}$ to 210 $^\circ\text{C}$.

$$r = 0.01520(x + 110)^\circ\text{C} \quad (10)$$

where:

x = the mean of two results.

15.1.2 *Reproducibility*—The difference between two single and independent results obtained by different operators working in different laboratories using different apparatus on identical test material, would, in the long run, in the normal and correct operation of this test method, exceed the following values only in 1 case in 20. For examples of precision, see Table 2; valid range 20 $^\circ\text{C}$ to 210 $^\circ\text{C}$.

$$R = 0.02561(x + 110)^\circ\text{C} \quad (11)$$

where:

x = the mean of two results.

15.2 *Bias*—The procedure in this test method has no bias because flash point can be defined only in terms of a test method.

15.2.1 *Relative Bias*—A relative bias assessment⁵ was carried out in accordance with Practice D6708 methodology between instruments using gas or electric ignitors. The statistical evaluation outcome did show a relative bias. The precision as reported in 15.1.1 and 15.1.2 represents a combination of gas and electric ignitors. In any case of dispute, the use of gas ignition shall be considered the referee.

15.3 *Precision ILS*—The precision data as shown in 15.1.1 and 15.1.2 were developed from a 2010 joint Energy Institute and ASTM interlaboratory study. Nineteen (19) laboratories (11 gas and 8 electric ignitors) tested 15 samples in duplicate covering a wide range of petroleum and related products with a flash point temperature range of 20 $^\circ\text{C}$ to 210 $^\circ\text{C}$. Full details of the study are given in the research report.⁵

NOTE 2—The three technical bodies, ASTM D02.08.B0 TG D3828 Revision, EI SC-B-4 Flammability, and ISO TC28 WG9 JWG Flash Point Test Methods, involved in the revision of D3828, IP 523, and EN ISO 3679, respectively, were all presented with the ILS Research Report and results of the ILS, and all three bodies agreed that a combination of gas and electric data should be used for the precision used in the test methods.

16. Keywords

16.1 combustible; fire risk; flammable; flash point; volatile

TABLE 2 Calculated Repeatability and Reproducibility for Petroleum and Related Products

Temperature, $^\circ\text{C}$	20	40	60	80	100	120	140	160	180	200	210
Repeatability, $^\circ\text{C}$	2.0	2.3	2.6	2.9	3.2	3.5	3.8	4.1	4.4	4.7	4.9
Reproducibility, $^\circ\text{C}$	3.3	3.8	4.4	4.9	5.4	5.9	6.4	6.9	7.4	7.9	8.2

⁵ Supporting data have been filed at the Energy Institute, 61 New Cavendish Street, London W1G 7AR, UK. <http://www.energyinst.org> and may be obtained by requesting Research Report IP 523/10.

ANNEXES

(Mandatory Information)

A1. FLASH TEST APPARATUS

A1.1 *Flash Test Apparatus*, see Fig. A1.1 and Table A1.1.

A1.2 *Test Cup*, consisting of an aluminum alloy or nonrusting metal block of suitable conductivity with a cylindrical depression over which is fitted a cover. A temperature measuring device is inserted in the block.

A1.2.1 The cover comprises a lid fitted with an opening shutter and a device capable of inserting an ignition source into the test cup when the shutter is open. When inserted, the nozzle

of the ignition source shall intersect the plane of the underside of the cover. The cover is also provided with an orifice extending into the sample well for insertion of the test specimen and also a suitable clamping device for securing the cover tightly to the metal block. The three openings in the cover shall be within the diameter of the sample well. When the shutter is in the open position, the two openings in the shutter shall coincide with the two corresponding openings in the cover.

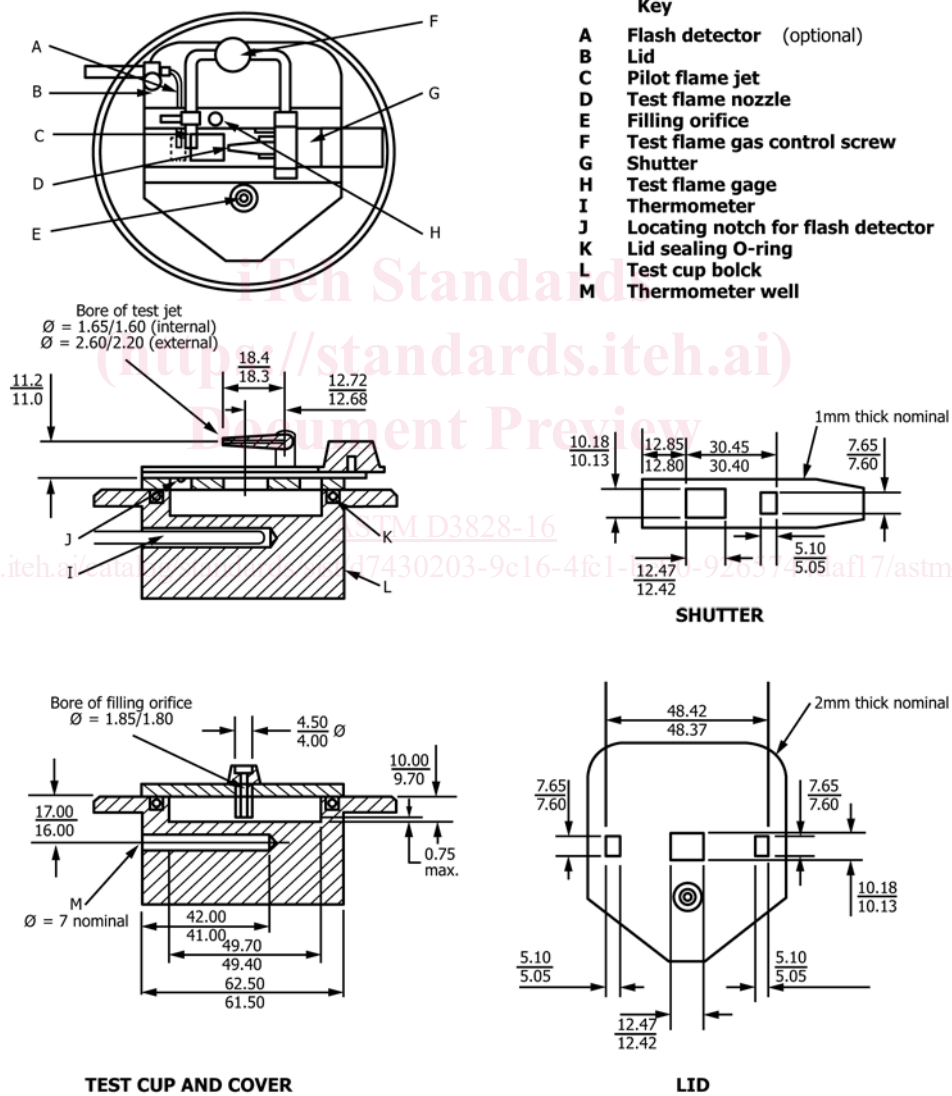

NOTE 1—All dimensions are in millimetres.

FIG. A1.1 Test Cup and Cover Assembly