



Designation: E454 – 12 (Reapproved 2016)

# Standard Specification for Industrial Perforated Plate and Screens (Square Opening Series)<sup>1</sup>

This standard is issued under the fixed designation E454; the number immediately following the designation indicates the year of original adoption or, in the case of revision, the year of last revision. A number in parentheses indicates the year of last reapproval. A superscript epsilon ( $\epsilon$ ) indicates an editorial change since the last revision or reapproval.

## INTRODUCTION

Industrial perforated plate can be produced in many thousands of combinations of size and shape of opening, bar size, thickness of material, and type of metal. Such variety is often confusing and, to the vast majority of perforated plate users, unnecessary, since each usually requires only a very few specifications.

The purpose of this specification is to simplify this problem by a condensed table of recommended specifications covering a wide range of openings in which industrial perforated plate is made, with several recommended bar sizes and thicknesses of plate for each opening, for use in various grades of service.

By making selections from this standard, the user will be guided to specifications that are being regularly produced, thus avoiding inadvertent selection of specifications that, because of little or no demand, are unobtainable, except on special order (usually quite expensive unless the quantity ordered is sufficient to justify the cost of special tooling).

If a user has a specific application for industrial perforated plate that can not be solved by a selection from this standard, it is recommended that he consult his perforated plate supplier on the availability of an acceptable alternative specification.

## 1. Scope

1.1 This specification covers the sizes of square opening perforated plate and screens for general industrial uses, including the separating or grading of materials according to designated nominal particle size, and lists standards for openings from 5 in. (125 mm) to 0.127 ( $\frac{1}{8}$ ) in. (3.35 mm) punched with bar sizes and thicknesses of plate for various grades of service. Methods of checking industrial perforated plate and screens are included as information in **Annex A3**.

1.2 This specification does not apply to perforated plate or screens with round, hexagon, slotted, or other shaped openings.

1.3 The values stated in inch-pound units are to be regarded as standard. The values given in parentheses are mathematical conversions to SI units that are provided for information only and are not considered standard.

1.4 *This standard does not purport to address all of the safety concerns, if any, associated with its use. It is the*

*responsibility of the user of this standard to establish appropriate safety and health practices and determine the applicability of regulatory limitations prior to use.*

## 2. Referenced Documents

2.1 *ASTM Standards:*<sup>2</sup>

**E323 Specification for Perforated-Plate Sieves for Testing Purposes**

**E1638 Terminology Relating to Sieves, Sieving Methods, and Screening Media**

2.2 *ISO Standards:*<sup>3</sup>

**ISO 2194 Industrial screens — Woven wire cloth, perforated plate and electroformed sheet — Designation and nominal sizes of openings**

<sup>1</sup> This specification is under the jurisdiction of ASTM Committee E29 on Particle and Spray Characterization and is the direct responsibility of Subcommittee E29.01 on Sieves, Sieving Methods, and Screening Media.

Current edition approved July 1, 2016. Published July 2016. Originally approved in 1972. Last previous edition approved in 2012 as E454 – 12. DOI: 10.1520/E0454-12R16.

<sup>2</sup> For referenced ASTM standards, visit the ASTM website, www.astm.org, or contact ASTM Customer Service at service@astm.org. For *Annual Book of ASTM Standards* volume information, refer to the standard's Document Summary page on the ASTM website.

<sup>3</sup> Available from International Organization for Standardization (ISO), 1, ch. de la Voie-Creuse, Case postale 56, CH-1211, Geneva 20, Switzerland, http://www.iso.ch.

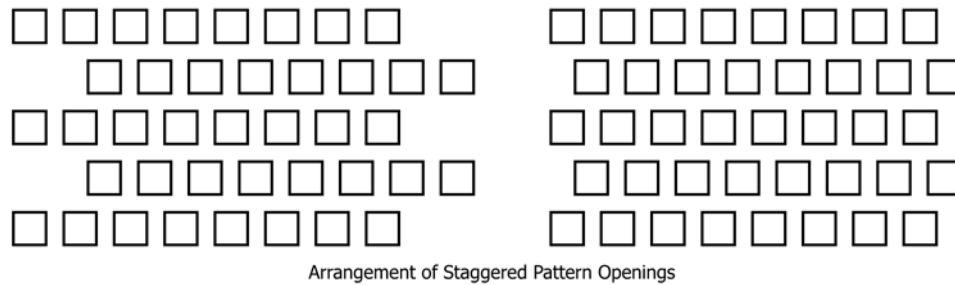
**FIG. 1 Unfinished End Pattern**
**Finished End Pattern**

### 2.3 Other Documents:

Fed. Std. No. 123 Marking for Shipment (Civil Agencies)<sup>4</sup>  
 Mil-Std-129 Marking for Shipment and Storage<sup>4</sup>

## 3. Terminology

### 3.1 Definitions:

3.1.1 For general terms related to sieves, sieving methods, and screening media, see Terminology E1638.

### 3.2 Definitions of Terms Specific to This Standard:

3.2.1 *aperture, n*—the opening in a screening or sieving medium.

3.2.2 *bar, n*—the metal between perforations.

3.2.3 *blank, n*—unperforated area located other than along the perimeter of a plate.

3.2.4 *break-out, n*—term applied to the action that occurs ahead of the punch in its going through the plate.

3.2.4.1 *Discussion*—The fracturing of the material results in a tapered hole with the small dimensions on the punch side.

3.2.5 *centers, n*—dimensional sum of one perforation and one bar or the dimensional distance from the center of one perforation to the center of an adjacent perforation.

3.2.6 *die side, n*—surface of the plate that was against the die during the punching operation.

3.2.7 *finished end pattern, n*—condition that occurs with some specifications of staggered pattern perforations as a result of tool design in which the pattern is completed on both ends of the plate (Fig. 1).

3.2.8 *gage* (also *gauge*), *n*—a number designating a specific thickness of metal sheet tabulated in a standardized series, each of which represents a decimal fraction of an inch.

3.2.9 *margin* or *border, n*—unperforated area located along the perimeter of a plate.

3.2.10 *percent open area, n*—the ratio of the total area of the apertures to the total area expressed in percentage.

3.2.11 *perforated pattern, n*—the patterns that the perforations are arranged in, usually in a staggered pattern with midpoints nominally at the vertices of isosceles triangles or square patterns arranged in line with their midpoints nominally at the vertices of squares.

3.2.12 *screen, n*—(1) surface provided with apertures of uniform size and shape; (2) another term used interchangeably for woven wire cloth; (3) machine provided with one or more screen surfaces.

3.2.13 *screening, v*—process of separating a mixture of different sizes by means of one or more screen surfaces.

3.2.14 *smooth side* or *punch side, n*—surface of the plate that was uppermost during the punching operation and through which the punch entered the plate.

3.2.15 *unfinished end pattern, n*—condition that occurs with some specifications of staggered pattern perforations as a result of tool design.

3.2.15.1 *Discussion*—On one end of the plate, the pattern will appear to be incomplete as a result of unperforated holes in the even numbered rows, while on the other end of the same plate, the pattern will appear to be incomplete because of unperforated holes in the odd numbered rows (Fig. 1).

## 4. Standard Specifications

4.1 Standard specifications for industrial perforated plate and screens are listed in Table 1.

4.2 *Openings*—The series of standard openings listed in Table 1 include those of the USA Standard Sieve Series, Specification E323, and those of the ISO apertures for industrial plate screens, ISO 2194, with the addition of those openings in common usage.

4.3 *Relationship of Grades*—The purpose of the several grades is to provide combinations of opening and bar size for various types of service, from medium-light to heavy. Since it is possible to vary the bar size independently from the plate thickness, each of the service grades lists up to three combinations of bar and gage for each opening. The entire standard series has been designed for a logical relationship of bar size to opening in each grade and between grades with the capability of also being able to vary the plate thickness.

<sup>4</sup> Available from Standardization Documents Order Desk, DODSSP, Bldg. 4, Section D, 700 Robbins Ave., Philadelphia, PA 19111-5098, <http://dodssp.daps.dla.mil>.

**TABLE 1 USA Standard Specifications for Industrial Perforated Plate and Screens (Square Opening Series)—(U.S. Customary Units)**

Perforated Opening			Medium Light				Medium				Medium Heavy				Heavy			
Standard (metric), mm	USA Industrial Standard, in.	Opening, in.	Bar, in.	Gage-Steel, in.	Open Area, percent	Opening, in.	Bar, in.	Gage-Steel, in.	Open Area, percent	Opening, in.	Bar, in.	Gage-Steel, in.	Open Area, percent	Opening, in.	Bar, in.	Gage-Steel, in.	Open Area, percent	
125	5	5	1/2	1/2	82.6	5	5/8	5/8	79.0	5	3/4	3/4	75.6	5	1	1	69.4	
125	5	5	5/8	5/8	79.0	5	3/4	1/2	75.6	5	7/8	5/8	72.4	5	1 1/8	7/8	66.6	
125	5	5	5/8	1/2	79.0	5	3/4	5/8	75.6	5	7/8	3/4	72.4	5	1 1/8	1	66.6	
...	...	4 1/2	1/2	1/2	81.0	4 1/2	5/8	5/8	77.1	4 1/2	3/4	3/4	73.4	4 1/2	1	1	66.9	
...	...	4 1/2	5/8	3/8	77.1	4 1/2	3/4	1/2	73.4	4 1/2	7/8	5/8	70.1	4 1/2	1 1/8	7/8	64.0	
...	...	4 1/2	5/8	1/2	77.1	4 1/2	3/4	5/8	73.4	4 1/2	7/8	3/4	70.1	4 1/2	1 1/8	1	64.0	
106	4 1/4	4 1/4	1/2	1/2	80.1	4 1/4	5/8	5/8	76.0	4 1/4	3/4	3/4	72.3	4 1/4	1	1	65.5	
106	4 1/4	4 1/4	5/8	3/8	76.0	4 1/4	3/4	1/2	72.3	4 1/4	7/8	5/8	68.8	4 1/4	1 1/8	7/8	62.5	
106	4 1/4	4 1/4	5/8	1/2	76.0	4 1/4	3/4	5/8	72.3	4 1/4	7/8	3/4	68.8	4 1/4	1 1/8	1	62.5	
100	4	4	1/2	1/2	79.0	4	5/8	5/8	74.8	4	3/4	3/4	70.9	4	1	1	64.0	
100	4	4	5/8	3/8	74.8	4	3/4	1/2	70.9	4	7/8	5/8	67.3	4	1 1/8	7/8	60.9	
100	4	4	5/8	1/2	74.8	4	3/4	5/8	70.9	4	7/8	3/4	67.3	4	1 1/8	1	60.9	
...	...	3 3/4	1/2	1/2	77.9	3 3/4	5/8	5/8	73.5	3 3/4	3/4	3/4	69.4	3 3/4	7/8	7/8	65.7	
...	...	3 3/4	5/8	3/8	73.5	3 3/4	3/4	1/2	69.4	3 3/4	7/8	5/8	65.7	3 3/4	1	3/4	62.3	
...	...	3 3/4	5/8	1/2	73.5	3 3/4	3/4	5/8	69.4	3 3/4	7/8	3/4	65.7	3 3/4	1	7/8	62.3	
90	3 1/2	3 1/2	1/2	1/2	76.6	3 1/2	5/8	5/8	72.0	3 1/2	3/4	3/4	67.8	3 1/2	7/8	7/8	64.0	
90	3 1/2	3 1/2	5/8	3/8	72.0	3 1/2	3/4	1/2	67.8	3 1/2	7/8	5/8	64.0	3 1/2	1	3/4	60.5	
90	3 1/2	3 1/2	5/8	1/2	72.0	3 1/2	3/4	5/8	67.8	3 1/2	7/8	3/4	64.0	3 1/2	1	7/8	60.5	
...	...	3 1/4	3/8	3/8	80.4	3 1/4	1/2	1/2	75.1	3 1/4	5/8	5/8	70.3	3 1/4	3/4	3/4	66.0	
...	...	3 1/4	1/2	5/16	75.1	3 1/4	5/8	3/8	70.3	3 1/4	3/4	1/2	66.0	3 1/4	7/8	5/8	62.1	
...	...	3 1/4	1/2	3/8	75.1	3 1/4	5/8	1/2	70.3	3 1/4	3/4	5/8	66.0	3 1/4	7/8	3/4	62.1	
75	3	3	3/8	3/8	79.0	3	1/2	1/2	73.5	3	5/8	5/8	68.5	3	3/4	3/4	64.0	
75	3	3	1/2	5/16	73.5	3	5/8	3/8	68.5	3	3/4	1/2	64.0	3	7/8	5/8	59.9	
75	3	3	1/2	3/8	73.5	3	5/8	1/2	68.5	3	3/4	5/8	64.0	3	7/8	3/4	59.9	
...	...	2 3/4	3/8	3/8	77.4	2 3/4	1/2	1/2	71.6	2 3/4	5/8	5/8	66.4	2 3/4	3/4	3/4	61.7	
...	...	2 3/4	1/2	5/16	71.6	2 3/4	5/8	3/8	66.4	2 3/4	3/4	1/2	61.7	2 3/4	7/8	5/8	57.6	
...	...	2 3/4	1/2	3/8	71.6	2 3/4	5/8	1/2	66.4	2 3/4	3/4	5/8	61.7	2 3/4	7/8	3/4	57.6	
63	2 1/2	2 1/2	3/8	3/8	75.6	2 1/2	1/2	1/2	69.4	2 1/2	5/8	5/8	64.0	2 1/2	3/4	3/4	59.2	
63	2 1/2	2 1/2	1/2	5/16	69.4	2 1/2	5/8	3/8	64.0	2 1/2	3/4	1/2	59.2	2 1/2	7/8	5/8	54.9	
63	2 1/2	2 1/2	1/2	3/8	69.4	2 1/2	5/8	1/2	64.0	2 1/2	3/4	5/8	59.2	2 1/2	7/8	3/4	54.9	
...	...	2 1/4	3/8	3/8	73.5	2 1/4	1/2	1/2	66.9	2 1/4	5/8	5/8	61.2	2 1/4	3/4	3/4	56.3	
...	...	2 1/4	1/2	5/16	66.9	2 1/4	5/8	3/8	61.2	2 1/4	3/4	1/2	56.3	2 1/4	7/8	5/8	51.8	
...	...	2 1/4	1/2	3/8	66.9	2 1/4	5/8	1/2	61.2	2 1/4	3/4	5/8	56.3	2 1/4	7/8	3/4	51.8	
53	2 1/8	2 1/8	5/16	5/16	76.0	2 1/8	3/8	3/8	72.3	2 1/8	1/2	1/2	65.5	2 1/8	5/8	5/8	59.7	
53	2 1/8	2 1/8	3/8	1/4	72.3	2 1/8	1/2	5/16	59.7	2 1/8	5/8	3/8	59.7	2 1/8	3/4	1/2	54.6	
53	2 1/8	2 1/8	3/8	5/16	72.3	2 1/8	1/2	3/8	59.7	2 1/8	5/8	1/2	59.7	2 1/8	3/4	5/8	54.6	
50	2	2	5/16	5/16	74.8	2	3/8	3/8	70.9	2	1/2	1/2	64.0	2	5/8	5/8	58.0	
50	2	2	3/8	1/4	70.9	2	1/2	5/16	64.0	2	5/8	3/8	58.0	2	3/4	1/2	52.9	
50	2	2	3/8	5/16	70.9	2	1/2	3/8	64.0	2	5/8	1/2	58.0	2	3/4	5/8	52.9	
...	...	1 7/8	5/16	5/16	73.5	1 7/8	3/8	3/8	69.4	1 7/8	1/2	1/2	62.3	1 7/8	5/8	5/8	56.3	
...	...	1 7/8	3/8	1/4	69.4	1 7/8	1/2	5/16	62.3	1 7/8	5/8	3/8	56.3	1 7/8	3/4	1/2	51.0	
...	...	1 7/8	3/8	5/16	69.4	1 7/8	1/2	3/8	62.3	1 7/8	5/8	1/2	56.3	1 7/8	3/4	5/8	51.0	
45	1 3/4	1 3/4	5/16	5/16	72.0	1 3/4	3/8	3/8	67.8	1 3/4	1/2	1/2	60.5	1 3/4	5/8	5/8	54.3	
45	1 3/4	1 3/4	3/8	1/4	67.8	1 3/4	1/2	5/16	60.5	1 3/4	5/8	3/8	49.0	1 3/4	3/4	1/2	49.0	
45	1 3/4	1 3/4	3/8	5/16	67.8	1 3/4	1/2	3/8	60.5	1 3/4	5/8	1/2	49.0	1 3/4	3/4	5/8	49.0	
...	...	1 5/8	1/4	1/4	75.1	1 5/8	5/16	5/16	70.3	1 5/8	3/8	3/8	66.0	1 5/8	1/2	1/2	58.5	
...	...	1 5/8	5/16	3/16	70.3	1 5/8	3/8	1/4	66.0	1 5/8	1/2	5/16	58.5	1 5/8	5/8	3/8	52.1	
...	...	1 5/8	5/16	1/4	70.3	1 5/8	3/8	5/16	66.0	1 5/8	1/2	3/8	58.5	1 5/8	5/8	1/2	52.1	
37.5	1 1/2	1 1/2	1/4	1/4	73.5	1 1/2	5/16	5/16	68.5	1 1/2	3/8	3/8	64.0	1 1/2	1/2	1/2	56.3	
37.5	1 1/2	1 1/2	5/16	3/16	68.5	1 1/2	3/8	1/4	64.0	1 1/2	1/2	5/16	56.3	1 1/2	5/8	3/8	49.8	
37.5	1 1/2	1 1/2	5/16	1/4	68.5	1 1/2	3/8	5/16	64.0	1 1/2	1/2	3/8	56.3	1 1/2	5/8	1/2	49.8	
...	...	1 3/8	1/4	1/4	71.6	1 3/8	5/16	5/16	66.4	1 3/8	3/8	3/8	61.7	1 3/8	1/2	1/2	53.8	
...	...	1 3/8	5/16	3/16	66.4	1 3/8	3/8	1/4	61.7	1 3/8	1/2	5/16	53.8	1 3/8	5/8	3/8	47.3	
...	...	1 3/8	5/16	1/4	66.4	1 3/8	3/8	5/16	61.7	1 3/8	1/2	3/8	53.8	1 3/8	5/8	1/2	47.3	



# E454 - 12 (2016)

### TABLE 1 Continued

Perforated Opening		Medium Light				Medium				Medium Heavy				Heavy			
Standard (metric), mm	USA Industrial Standard, in.	Opening, in.	Bar, in.	Gage-Steel, in.	Open Area, percent	Opening, in.	Bar, in.	Gage-Steel, in.	Open Area, percent	Opening, in.	Bar, in.	Gage-Steel, in.	Open Area, percent	Opening, in.	Bar, in.	Gage-Steel, in.	Open Area, percent
31.5	1¼	1¼	¼	¼	69.4	1¼	5/16	5/16	64.0	1¼	¾	¾	59.2	1¼	½	½	51.0
31.5	1¼	1¼	5/16	3/16	64.0	1¼	¾	¼	59.2	1¼	½	5/16	51.0	1¼	5/8	¾	44.4
31.5	1¼	1¼	5/16	¼	64.0	1¼	¾	5/16	59.2	1¼	½	¾	51.0	1¼	5/8	½	44.4
...	...	13/16	3/16	3/16	74.6	13/16	¼	¼	68.2	13/16	5/16	5/16	62.7	13/16	¾	¾	57.8
...	...	13/16	¼	8	68.2	13/16	5/16	3/16	62.7	13/16	¾	¼	57.8	13/16	½	5/16	49.5
...	...	13/16	¼	3/16	68.2	13/16	5/16	¼	62.7	13/16	¾	5/16	57.8	13/16	½	¾	49.5
...	...	1½	3/16	3/16	73.5	1½	¼	¼	66.9	1½	5/16	5/16	61.2	1½	¾	¾	56.3
...	...	1½	¼	8	66.9	1½	5/16	3/16	61.2	1½	¾	¼	56.3	1½	½	5/16	47.9
...	...	1½	¼	3/16	66.9	1½	5/16	¼	61.2	1½	¾	5/16	56.3	1½	½	¾	47.9
26.5	1½	1½	3/16	3/16	72.2	1½	¼	¼	65.5	1½	5/16	5/16	59.7	1½	¾	¾	54.6
26.5	1½	1½	¼	8	65.5	1½	5/16	3/16	59.7	1½	¾	¼	54.6	1½	½	5/16	46.2
26.5	1½	1½	¼	3/16	65.5	1½	5/16	¼	59.7	1½	¾	5/16	54.6	1½	½	¾	46.2
25	1	1	3/16	3/16	70.9	1	¼	¼	64.0	1	5/16	5/16	58.0	1	¾	¾	52.9
25	1	1	¼	8	64.0	1	5/16	3/16	58.0	1	¾	¼	52.9	1	½	5/16	44.4
25	1	1	¼	3/16	64.0	1	5/16	¼	58.0	1	¾	5/16	52.9	1	½	¾	44.4
...	...	15/16	3/16	3/16	69.4	15/16	¼	¼	62.3	15/16	5/16	5/16	56.2	15/16	¾	¾	51.0
...	...	15/16	¼	8	62.3	15/16	5/16	3/16	56.2	15/16	¾	¼	51.0	15/16	½	3/16	42.5
...	...	15/16	¼	3/16	62.3	15/16	5/16	¼	56.2	15/16	¾	5/16	51.0	15/16	½	¾	42.5
22.4	7/8	7/8	3/16	3/16	67.8	7/8	¼	¼	60.5	7/8	5/16	5/16	54.3	7/8	¾	¾	49.0
22.4	7/8	7/8	¼	8	60.5	7/8	5/16	3/16	54.3	7/8	¾	¼	49.0	7/8	½	5/16	40.5
22.4	7/8	7/8	¼	3/16	60.5	7/8	5/16	¼	54.3	7/8	¾	5/16	49.0	7/8	½	¾	40.5
...	...	13/16	3/16	3/16	66.0	13/16	¼	¼	58.5	13/16	5/16	5/16	52.2	13/16	¾	¾	46.8
...	...	13/16	¼	8	58.5	13/16	5/16	3/16	52.2	13/16	¾	¼	46.8	13/16	½	5/16	38.3
...	...	13/16	¼	3/16	58.5	13/16	5/16	¼	52.2	13/16	¾	5/16	46.8	13/16	½	¾	38.3
19	¾	¾	3/16	3/16	64.0	¾	¼	¼	56.3	¾	5/16	5/16	49.8	¾	¾	¾	44.4
19	¾	¾	¼	8	56.3	¾	5/16	3/16	49.8	¾	¾	¼	44.4	¾	½	5/16	36.0
19	¾	¾	¼	3/16	56.3	¾	5/16	¼	49.8	¾	¾	5/16	44.4	¾	½	¾	36.0
...	...	1½	3/16	3/16	61.7	1½	¼	¼	53.8	1½	5/16	5/16	47.2	1½	¾	¾	41.9
...	...	1½	¼	8	53.8	1½	5/16	3/16	47.2	1½	¾	¼	41.9	1½	½	5/16	33.5
...	...	1½	¼	3/16	53.8	1½	5/16	¼	47.2	1½	¾	5/16	41.9	1½	½	¾	33.5
16	5/8	5/8	5/32	8	64.0	5/8	3/16	3/16	59.2	5/8	¼	¼	51.0	5/8	5/16	5/16	44.4
16	5/8	5/8	3/16	10	59.2	5/8	¼	8	51.0	5/8	5/16	3/16	44.4	5/8	¾	¼	39.1
16	5/8	5/8	3/16	8	59.2	5/8	¼	3/16	51.0	5/8	5/16	¼	44.4	5/8	¾	5/16	39.1
...	...	9/16	5/32	8	61.2	9/16	3/16	3/16	56.2	9/16	¼	¼	47.9	9/16	5/16	5/16	41.3
...	...	9/16	3/16	10	56.2	9/16	¼	8	47.9	9/16	5/16	3/16	41.3	9/16	¾	¼	36.0
...	...	9/16	3/16	8	56.2	9/16	¼	3/16	47.9	9/16	5/16	¼	41.3	9/16	¾	5/16	36.0
13.2	17/32	17/32	1/8	10	65.5	17/32	5/32	8	59.7	17/32	3/16	3/16	54.6	17/32	¼	¼	46.2
13.2	17/32	17/32	5/32	11	59.7	17/32	3/16	10	54.6	17/32	¼	8	46.2	17/32	5/16	3/16	39.6
13.2	17/32	17/32	5/32	10	59.7	17/32	3/16	8	54.6	17/32	¼	3/16	46.2	17/32	5/16	¼	39.6
12.5	½	½	1/8	10	64.0	½	5/32	8	58.0	½	3/16	3/16	52.9	½	¼	¼	44.4
12.5	½	½	5/32	11	58.0	½	3/16	10	52.9	½	¼	8	44.4	½	5/16	3/16	37.9
12.5	½	½	5/32	10	58.0	½	3/16	8	52.9	½	¼	3/16	44.4	½	5/16	¼	37.9
...	...	15/32	1/8	10	62.3	15/32	5/32	8	56.2	15/32	3/16	3/16	51.0	15/32	¼	¼	42.5
...	...	15/32	5/32	11	56.2	15/32	3/16	10	51.0	15/32	¼	8	42.5	15/32	5/16	3/16	36.0
...	...	15/32	5/32	10	56.2	15/32	3/16	8	51.0	15/32	¼	3/16	42.5	15/32	5/16	¼	36.0
11.2	7/16	7/16	1/8	10	60.5	7/16	5/32	8	54.3	7/16	3/16	3/16	49.0	7/16	¼	¼	40.5
11.2	7/16	7/16	5/32	11	54.3	7/16	3/16	10	49.0	7/16	¼	8	40.5	7/16	5/16	3/16	34.0
11.2	7/16	7/16	5/32	10	54.3	7/16	3/16	8	49.0	7/16	¼	3/16	40.5	7/16	5/16	¼	34.0
9.5	¾	¾	3/32	11	64.0	¾	1/8	10	56.3	¾	5/32	8	49.8	¾	3/16	3/16	44.4
9.5	¾	¾	1/8	12	56.3	¾	5/32	11	49.8	¾	3/16	10	44.4	¾	¼	8	36.0
9.5	¾	¾	1/8	11	56.3	¾	5/32	10	49.8	¾	3/16	8	44.4	¾	¼	3/16	36.0
8	5/16	5/16	3/32	11	59.2	5/16	1/8	10	51.0	5/16	5/32	7	44.4	5/16	3/16	3/16	39.0
8	5/16	5/16	1/8	12	51.0	5/16	5/32	11	44.4	5/16	3/16	10	39.0	5/16	¼	8	30.9
8	5/16	5/16	1/8	11	51.0	5/16	5/32	10	44.4	5/16	3/16	8	39.0	5/16	¼	3/16	30.9

TABLE 1 Continued

Perforated Opening		Medium Light				Medium				Medium Heavy				Heavy			
Standard (metric), mm	USA Industrial Standard, in.	Opening, in.	Bar, in.	Gage-Steel, in.	Open Area, percent	Opening, in.	Bar, in.	Gage-Steel, in.	Open Area, percent	Opening, in.	Bar, in.	Gage-Steel, in.	Open Area, percent	Opening, in.	Bar, in.	Gage-Steel, in.	Open Area, percent
6.7	17/64	...	...	...	...	17/64	3/32	11	54.6	17/64	1/8	10	46.2	17/64	5/32	8	39.6
6.7	17/64	17/64	3/32	14	54.6	17/64	1/8	12	46.2	17/64	5/32	11	39.6	17/64	3/16	10	34.4
6.7	19/64	17/64	3/32	12	54.6	17/64	1/8	11	46.2	17/64	5/32	11	39.6	17/64	3/16	8	34.4
6.3	1/4	...	...	...	...	1/4	3/32	11	52.9	1/4	1/8	10	44.4	1/4	5/32	8	37.9
6.3	1/4	1/4	3/32	14	52.9	1/4	1/8	12	44.4	1/4	5/32	11	37.9	1/4	3/16	10	32.7
6.3	1/4	1/4	3/32	12	52.9	1/4	1/8	11	44.4	1/4	5/32	10	37.9	1/4	3/16	8	32.7
5.6	7/32	...	...	...	...	...	...	...	...	7/32	3/32	11	49.0	7/32	1/8	10	40.5
5.6	7/32	...	...	...	...	7/32	3/32	14	4.0	7/32	1/8	12	40.5	7/32	5/32	11	34.0
5.6	7/32	...	...	...	...	7/32	3/32	12	49.0	7/32	1/8	11	40.5	7/32	5/32	10	34.0
4.75	3/16	...	...	...	...	...	...	...	...	3/16	3/32	11	44.4	3/16	1/8	10	36.0
4.75	3/16	...	...	...	...	3/16	3/32	14	44.4	3/16	1/4	12	36.0	3/16	5/32	11	29.8
4.75	3/16	...	...	...	...	3/16	3/32	12	44.4	3/16	1/8	11	36.0	3/16	5/32	10	29.8
4	5/32	...	...	...	...	...	...	...	...	...	...	...	...	5/32	3/32	11	39.1
4	5/32	...	...	...	...	...	...	...	...	5/32	3/32	14	39.1	5/32	1/8	12	30.9
4	5/32	...	...	...	...	...	...	...	...	5/32	3/32	12	39.1	5/32	1/8	11	30.9
3.35	1/8	...	...	...	...	...	...	...	...	...	...	...	...	...	...	...	...
3.35	1/8	...	...	...	...	...	...	...	...	...	...	...	...	1/8	3/32	14	32.7
3.25	1/8	...	...	...	...	...	...	...	...	...	...	...	...	1/8	3/32	12	32.7

4.4 Bar—A choice of six bars is shown for each standard opening from 5- to 0.312-in. (125- to 8-mm) opening, inclusive. For practical reasons, the number of bars or grades available for openings finer than 0.312 in. (8 mm) is progressively reduced.

4.5 Gage—A choice of six gages is shown for each standard opening for 5 to 0.312 in. (125 to 8 mm). For practical reasons, the number of gages or grades available for openings finer than 0.312 in. (8 mm) is progressively reduced.

NOTE 1—The gages shown in Table 1 are practical for a low-carbon steel plate. For other materials, consult your perforated plate supplier.

4.6 Equivalent Metric Specification—Table A1.1, in the Annex A1, shows the equivalent metric specifications to the USA Standard.

5. Types of Perforated Pattern

5.1 This specification covers square openings arranged in a staggered pattern with their midpoints nominally at the vertices of isosceles triangles whose bases shall equal their heights, and also covers square openings arranged in line with their midpoints nominally at the vertices of squares (see Fig. 2).

NOTE 2—The percentage of open area for square apertures is identical for both staggered and straight-line patterns (see Fig. 2).

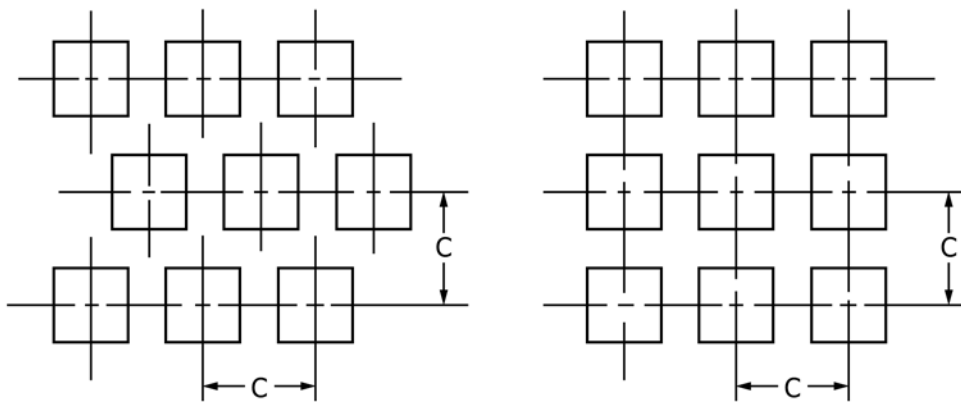

Types of Perforated Pattern  
 FIG. 2 Staggered Pattern                      Straight-Line Pattern

6. Metal Composition of Plate

6.1 Perforated plate can be punched from a great variety of metals and alloys, but the following are most commonly used:

- Steel, low-carbon
- Steel, high-carbon
- Steel, heat-treated
- Steel, galvanized
- Stainless steel, Type 304
- Stainless steel, Type 316
- Stainless steel, Type 410
- Brass (Cu 80, Zn 20)
- Manganese bronze (Cu 61, Zn 37)
- Monel (high nickel-copper alloy)
- Aluminum (all grades)

7. Tolerances

7.1 *Openings*—Tolerances on openings in USA Standard Specifications for Industrial Perforated Plate and Screens (Table 1 and Table A1.1) shall be in accordance with those listed in Table 2.

7.2 *Bars*—Tolerances on bars used in USA Standard Specification for Industrial Perforated Plate and Screens (Table 1 and Table A1.1) shall be in accordance with those listed in Table 3.

7.3 *Gages*—Tolerances on gages used in USA Standard Specifications for Industrial Perforated Plate and Screens (Table 1 and Table A1.1) shall be in accordance with those listed in Table 4.

NOTE 3—The tolerances expressed in inch-pound units are taken from the current AISI<sup>5</sup> values.

8. Keywords

8.1 industrial perforated plate; industrial screens; openings; particle size; perforated openings; perforated plate; screens

<sup>5</sup> Available from American Iron and Steel Institute (AISI), 1140 Connecticut Ave., NW, Suite 705, Washington, DC 20036, <http://www.steel.org>.

TABLE 2 Tolerances on Openings of USA Standard Specifications for Industrial Perforated Plate and Screens

Standard (metric), mm	Perforated Opening				Tolerance on Openings	
	USA Industrial Standard, in.	Additional Sizes, in.	Standard (metric), mm	USA Industrial Standard, in.	Standard (metric), mm	USA Industrial Standard, in.
125.0	5	...	±2.5	±0.100	125.0	5
...	...	4½	...	±0.090	...	...
106.0	4¼	...	±2.1	±0.085	106.0	4¼
100.0	4	...	±2.0	±0.080	100.0	4
...	...	3¾	...	±0.075	...	3¾
90.0	3½	...	±1.8	±0.070	90.0	3½
...	...	3¼	...	±0.065	...	3¼
75.0	3	...	±1.5	±0.060	75.0	3
...	...	2¾	...	±0.055	...	2¾
63.0	2½	...	±1.3	±0.050	63.0	2½
...	...	2¼	...	±0.045	...	2¼
53.0	2⅞	...	±1.1	±0.043	53.0	2⅞
50.0	2	...	±1.0	±0.040	50.0	2
...	...	1⅞	...	±0.038	...	1⅞
45.0	1¾	...	±0.9	±0.035	45.0	1¾
...	...	1⅝	...	±0.033	...	1⅝
37.5	1½	...	±0.8	±0.030	37.5	1½
...	...	1⅜	...	±0.028	...	1⅜
31.5	1¼	...	±0.6	±0.025	31.5	1¼
...	...	1⅓	...	±0.024	...	1⅓
...	...	1⅛	...	±0.023	...	1⅛
26.5	1⅛	...	±0.5	±0.021	26.5	1⅛
25.0	1	...	±0.5	±0.020	25.0	1
...	...	15/16	...	±0.019	...	15/16
22.4	7/8	...	±0.46	±0.018	22.4	7/8
...	...	13/16	...	±0.016	...	13/16
19.0	¾	...	±0.38	±0.015	19.0	¾
...	...	11/16	...	±0.014	...	11/16
16.0	5/8	...	±0.32	±0.013	16.0	5/8
...	...	9/16	...	±0.012	...	9/16
13.2	17/32	...	±0.30	±0.012	13.2	17/32
12.5	½	...	±0.28	±0.011	12.5	½
...	...	15/32	...	±0.011	...	15/32
11.2	7/16	...	±0.28	±0.011	11.2	7/16
9.5	3/8	...	±0.28	±0.010	9.5	3/8
8.0	5/16	...	±0.26	±0.010	8.0	5/16
6.7	17/64	...	±0.25	±0.009	6.7	17/64
6.3	¼	...	±0.25	±0.009	6.3	¼
5.6	7/32	...	±0.24	±0.009	5.6	7/32
4.75	3/16	...	±0.21	±0.008	4.75	3/16
4.00	5/32	...	±0.19	±0.007	4.00	5/32
3.35	0.127 (1/8)	...	±0.17	±0.006	3.5	0.127 (1/8)

TABLE 3 Tolerances on Bars of USA Standard Specifications for Industrial Perforated Plate and Screens

Standard (metric), mm	Perforated Opening			Tolerance on Average Bar		
	USA Industrial Standard, in.	Additional Sizes, in.	Standard (metric), mm	USA Industrial Standard, in.	Standard (metric), mm	
125.0	5	...	±3.2	±0.125	125.0	5
...	...	4½	...	±0.122	...	...
106.0	4¼	...	±2.9	±0.113	106.0	4¼
100.0	4	...	±2.7	±0.107	100.0	4
...	...	3¾	...	±0.102	...	3¾
90.0	3½	...	±2.5	±0.097	90.0	3½
...	...	3¼	...	±0.089	...	3¼
75.0	3	...	±2.1	±0.081	75.0	3
...	...	2¾	...	±0.076	...	2¾
63.0	2½	...	±1.8	±0.069	63.0	2½
...	...	2¼	...	±0.063	...	2¼
53.0	2⅞	...	±1.5	±0.059	53.0	2⅞
50.0	2	...	±1.4	±0.056	50.0	2
...	...	1⅞	...	±0.054	...	1⅞
45.0	1¾	...	±1.3	±0.051	45.0	1¾
...	...	1⅝	...	±0.047	...	1⅝
37.5	1½	...	±1.1	±0.043	37.5	1½
...	...	1⅜	...	±0.040	...	1⅜
31.5	1¼	...	±0.9	±0.037	31.5	1¼
...	...	1⅓	...	±0.035	...	1⅓
...	...	1⅛	...	±0.034	...	1⅛
26.5	1⅛	...	±0.8	±0.032	26.5	1⅛
25.0	1	...	±0.8	±0.030	25.0	1
...	...	15/16	...	±0.029	...	15/16
22.4	7/8	...	±0.7	±0.028	22.4	7/8
...	...	13/16	...	±0.026	...	13/16
19.0	¾	...	±0.6	±0.024	19.0	¾
...	...	11/16	...	±0.022	...	11/16
16.0	5/8	...	±0.5	±0.021	16.0	5/8
...	...	9/16	...	±0.019	...	9/16
13.2	17/32	...	±0.46	±0.018	13.2	17/32
12.5	½	...	±0.44	±0.017	12.5	½
...	...	15/32	...	±0.017	...	15/32
11.2	7/16	...	±0.41	±0.016	11.2	7/16
9.5	3/8	...	±0.36	±0.014	9.5	3/8
8.0	5/16	...	±0.32	±0.013	8.0	5/16
6.7	17/64	...	±0.29	±0.011	6.7	17/64
6.3	¼	...	±0.28	±0.011	6.3	¼
5.6	7/32	...	±0.27	±0.011	5.6	7/32
4.75	3/16	...	±0.23	±0.009	4.75	3/16
4.00	5/32	...	±0.22	±0.009	4.00	5/32
3.5	0.127 (1/8)	...	±0.20	±0.008	3.5	0.127 (1/8)