



Designation: D5571 – 16

Standard Test Method for Environmental Stress Crack Resistance (ESCR) of Plastic Tighthead Drums Not Exceeding 60 Gal (227 L) in Rated Capacity¹

This standard is issued under the fixed designation D5571; the number immediately following the designation indicates the year of original adoption or, in the case of revision, the year of last revision. A number in parentheses indicates the year of last reapproval. A superscript epsilon (ϵ) indicates an editorial change since the last revision or reapproval.

1. Scope

1.1 This test method provides an indication of the environmental stress crack resistance of plastic tighthead drums as a summation of the effects of container design, resin, manufacturing conditions, field performance, and other factors.

1.2 This test method may be used to evaluate a plastic drum's resistance to failure by cracking when in the presence of chemical and physical stresses.

1.3 Two procedures are provided as follows:

1.3.1 *Procedure A*—Internal pressure stress crack resistance method to nonyl phenoxypoly (ethyleneoxy) ethanol solution, a stress cracking reagent. The internal pressure is controlled at a constant elevated pressure and temperature.

1.3.2 *Procedure B*—Top-load stress crack resistance method to nonyl phenoxypoly ethanol, a stress cracking reagent. The compressive top load is controlled at a constant weight while maintaining an elevated temperature.

1.4 Although these procedures are not designed to test the ability of the closure or closure gasket material to retain the test reagent, the inclusion of closure failure as a container failure mode is optional. However, leakage through a closure may affect the internal pressure that could affect the test results.

1.5 This test method does not attempt to address all factors that could lead to stress cracking of plastic drums. The user of this standard may use other test parameters, such as top loads, chemical reagents, etc., as agreed upon between the user and supplier in the event of a drum qualification or purchase agreement.

1.6 The values stated in inch-pound units are to be regarded as the standard. The SI units given in parentheses are for information only.

1.7 *This standard does not purport to address all of the safety concerns, if any, associated with its use. It is the*

responsibility of the user of this standard to establish appropriate safety and health practices and determine the applicability of regulatory limitations prior to use. Specific warning statements are given in 6.2.

2. Referenced Documents

2.1 *ASTM Standards*:²

D996 Terminology of Packaging and Distribution Environments

D4577 Test Method for Compression Resistance of a Container Under Constant Load

E122 Practice for Calculating Sample Size to Estimate, With Specified Precision, the Average for a Characteristic of a Lot or Process

3. Terminology

3.1 *Definitions*—Reference Terminology D996 for definitions of terms applicable to this test method.

3.2 *Definitions of Terms Specific to This Standard*:

3.2.1 *environmental stress crack*—a crack that develops when a plastic drum is exposed to chemical and physical stresses.

3.2.2 *plastic tighthead drum*—A non-removable head plastic drum, maximum capacity not exceeding 60 gal (227 L), with openings for filling and emptying not exceeding 2.76 in. (70 mm) in diameter.

3.2.3 *stress crack failure*—any environmental stress crack that penetrates through the thickness of the drum resulting in a loss or leakage of the test reagent shall be interpreted as a failure.

4. Summary of Test Method

4.1 *Procedure A*—Exposes a minimum of three partly filled plastic drums to the action of a stress cracking reagent, within

¹ This test method is under the jurisdiction of ASTM Committee D10 on Packaging and is the direct responsibility of Subcommittee D10.21 on Shipping Containers and Systems - Application of Performance Test Methods.

Current edition approved June 1, 2016. Published July 2016. Originally approved in 1994. Last previous edition approved in 2010 as D5571-94 (2010). DOI: 10.1520/D5571-16.

² For referenced ASTM standards, visit the ASTM website, www.astm.org, or contact ASTM Customer Service at service@astm.org. For *Annual Book of ASTM Standards* volume information, refer to the standard's Document Summary page on the ASTM website.

the container, at an elevated internal pressure and elevated temperature. The test duration shall be 14 days, or as specified by the user.

4.2 *Procedure B*—Exposes a minimum of three plastic drums to a mechanical top load at elevated temperatures. The drums are filled to rated capacity with a stress cracking reagent and sealed prior to the load being applied. The test duration shall be 14 days, or as specified by the user.

5. Significance and Use

5.1 These procedures provide an indication of the environmental stress-crack resistance of plastic tighthhead drums. This test method may be used for determining the applicability of various plastic resins, mold designs, processing techniques and parameters for plastic tighthhead drums.

5.2 Environmental stress cracking is indicative of what results when a container is exposed to chemical agents such as soaps, organics, bleaches, or any surface active solutions while under conditions of stress.

5.3 Environmental stress cracking is a mechanism of chemical attack that is highly dependent upon the test reagent, resin, container manufacturing or processing history, exposure temperature, applied stress and other factors. The combination of these factors may result in eventual stress crack failure.

5.4 Both procedures minimize the potential for test variability by providing the user with rigidly defined test conditions. This test method may be used as design qualification and auditing tools for plastic tighthhead drums.

5.5 This test method is not meant to provide a quantitative value of measurement (that is, number of days to failure). It is intended only as a pass/fail procedure in accordance with user’s specifications, or as agreed upon between the user and supplier. It is not intended as a predictor or indicator of field performance regarding time to failure.

6. Apparatus

6.1 *Environmental Chamber*—The environmental chamber should be capable of maintaining a temperature control of $\pm 2.5^\circ\text{F}$ ($\pm 1.4^\circ\text{C}$) of set point. For best circulation and a constant temperature throughout, a forced air system is recommended.

6.2 *Top Load (for Procedure B only)*—Requires free weights (dead load) be placed on top of the specimens in amounts necessary to equal the specified top load. The deadload base should be of sufficient dimensions to completely cover the top perimeter of the drum. A calibrated pneumatic or hydraulic cylinder may be substituted for the free weights. (**Warning**—The potential exists for catastrophic stress-crack failure causing an instability of the applied topload. Precautionary steps should be taken (that is, allow drum failure but restrain the top load) to reduce the chance of injury to the operator or damage to the chamber and surrounding test drums.)

6.3 *For Procedure A Only:*

6.3.1 The essential parts of this apparatus are shown in Fig. 1. The necessary equipment is as follows:

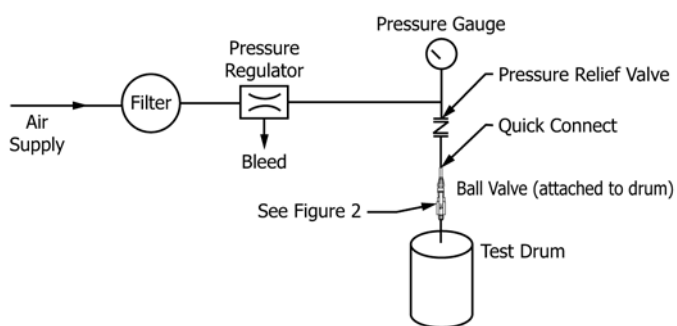

FIG. 1 Apparatus for Procedure A

6.3.1.1 *Clean (Compressed) Air Supply*, of sufficient pressure to operate regulator and maintain regulated pressure to drums.

6.3.1.2 *Pressure Regulator*, to reduce line pressure to 2.0 ± 0.1 psi (13.8 ± 0.7 kPa).

6.3.1.3 *Pressure Gages*, calibrated to indicate a pressure of 2.0 ± 0.05 psi (13.8 ± 0.34 kPa).

6.3.1.4 *Ball Valve*—see Fig. 2.

6.3.1.5 *Pressure Relief Valve*, to prevent over pressurizing (ruptured disc-type recommended).

7. Reagent

7.1 *Nonyl Phenoxypoly Ethanol Solution*—Prepare a 10 % solution, by volume, of the stress cracking agent and water in sufficient volume to fill the specified number of drums to 10 % rated capacity for Procedure A, and to rated capacity for Procedure B. (It may be helpful to add an indicator dye to the solution to aid in the detection of micro-leaks).

NOTE 1—Due to the viscosity of the stress cracking agent, it may be helpful to prepare the solution at an elevated temperature. A maximum temperature of 122°F (50°C) is an acceptable level provided caution is used to avoid prolonged heating and eventual volume losses.

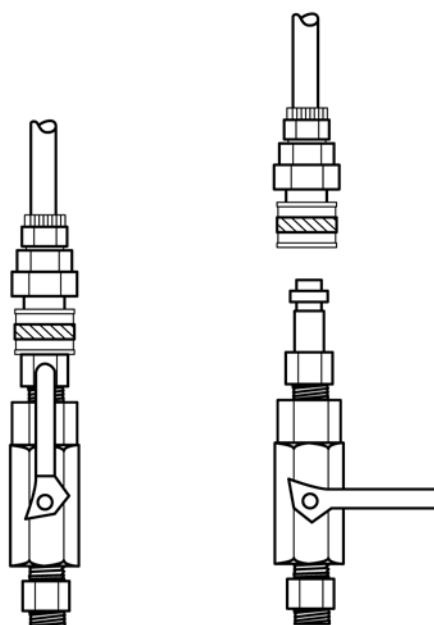

FIG. 2 Quick Connect With Ball Valve