



Designation: **C698 – 10 C698 – 16**

Standard Test Methods for Chemical, Mass Spectrometric, and Spectrochemical Analysis of Nuclear-Grade Mixed Oxides ((U, Pu)O₂)¹

This standard is issued under the fixed designation C698; the number immediately following the designation indicates the year of original adoption or, in the case of revision, the year of last revision. A number in parentheses indicates the year of last reapproval. A superscript epsilon (ε) indicates an editorial change since the last revision or reapproval.

1. Scope

1.1 These test methods cover procedures for the chemical, mass spectrometric, and spectrochemical analysis of nuclear-grade mixed oxides, (U, Pu)O₂, powders and pellets to determine compliance with specifications.

1.2 The analytical procedures appear in the following order:

	Sections
Uranium in the Presence of Pu by Potentiometric Titration	2
Plutonium by Controlled-Potential Coulometry	2
Plutonium by Amperometric Titration with Iron (II)	2
Nitrogen by Distillation-Spectrophotometry Using Nessler Reagent	7 to 14
Nitrogen by Distillation Spectrophotometry Using Nessler Reagent	8 to 15
Carbon (Total) by Direct Combustion-Thermal Conductivity	15 to 26
Carbon (Total) by Direct Combustion-Thermal Conductivity	16 to 26
Total Chlorine and Fluorine by Pyrohydrolysis	27 to 34
Sulfur by Distillation-Spectrophotometry	35 to 43
Moisture by the Coulometric, Electrolytic Moisture Analyzer	44 to 51
Isotopic Composition by Mass Spectrometry	3
Rare Earths by Copper Spark Spectroscopy	52 to 59
Trace Impurities by Carrier Distillation Spectroscopy	60 to 69
Trace Impurities by Carrier Distillation Spectroscopy	60 to 68
Impurities by Spark-Source Mass Spectrography	70 to 76
Impurities by Spark-Source Mass Spectrography	69 to 75
Total Gas in Reactor-Grade Mixed Dioxide Pellets	77 to 84
Total Gas in Reactor-Grade Mixed Dioxide Pellets	4
Tungsten by Dithiol-Spectrophotometry	85 to 93
Tungsten by Dithiol-Spectrophotometry	76 to 84
Rare Earth Elements by Spectroscopy	94 to 97
Rare Earth Elements by Spectroscopy	85 to 88
Plutonium-238 Isotopic Abundance by Alpha Spectrometry	5
Americium-241 in Plutonium by Gamma-Ray Spectrometry	98 to 106
Uranium and Plutonium Isotopic Analysis by Mass Spectrometry	98 to 106
Uranium and Plutonium Isotopic Analysis by Mass Spectrometry	89 to 97
Oxygen-to-Metal Atom Ratio by Gravimetry	107 to 115
Oxygen-to-Metal Atom Ratio by Gravimetry	98 to 105

1.3 The values stated in SI units are to be regarded as standard. The values given in parentheses are for information only.

1.4 *This standard does not purport to address all of the safety concerns, if any, associated with its use. It is the responsibility of the user of this standard to establish appropriate safety and health practices and determine the applicability of regulatory limitations prior to use.* (For specific ~~safeguard~~ and safety precaution statements, see Sections ~~116~~, ~~2013.2.5~~, ~~6441.7~~, and ~~112 and 102.6-193.6.1~~.)

¹ These test methods are under the jurisdiction of ASTM Committee C26 on Nuclear Fuel Cycle and are the direct responsibility of Subcommittee C26.05 on Methods of Test.

Current edition approved June 1, 2010/June 1, 2016. Published July 2010/July 2016. Originally approved in 1972. Last previous edition approved in 2004/2010 as C698 – 04-C698 – 10. DOI: 10.1520/C0698-10:10.1520/C0698-16.

² Discontinued as of November 15, 1992.

³ Discontinued as of May 30, 1980.

⁴ Discontinued as of January 1, 2004/June 2016.

⁵ Discontinued as of January 1, 2004.

2. Referenced Documents

2.1 ASTM Standards:⁶

- [C697](#) Test Methods for Chemical, Mass Spectrometric, and Spectrochemical Analysis of Nuclear-Grade Plutonium Dioxide Powders and Pellets
- [C833](#) Specification for Sintered (Uranium-Plutonium) Dioxide Pellets
- [C852](#) Guide for Design Criteria for Plutonium Gloveboxes
- [C1008](#) Specification for Sintered (Uranium-Plutonium) Dioxide Pellets—Fast Reactor Fuel (Withdrawn 2014)⁶
- ~~[E1009](#)~~ ~~[C859](#)~~ ~~Guide for Establishing and Maintaining a Quality Assurance Program for Analytical Laboratories Within the Nuclear Industry~~ ~~Terminology Relating to Nuclear Materials~~
- [C1068](#) Guide for Qualification of Measurement Methods by a Laboratory Within the Nuclear Industry
- [C1108](#) Test Method for Plutonium by Controlled-Potential Coulometry
- ~~[E1128](#)~~ ~~Guide for Preparation of Working Reference Materials for Use in Analysis of Nuclear Fuel Cycle Materials~~
- ~~[E1156](#)~~ ~~Guide for Establishing Calibration for a Measurement Method Used to Analyze Nuclear Fuel Cycle Materials~~
- [C1165](#) Test Method for Determining Plutonium by Controlled-Potential Coulometry in H₂SO₄ at a Platinum Working Electrode
- [C1168](#) Practice for Preparation and Dissolution of Plutonium Materials for Analysis
- [C1204](#) Test Method for Uranium in Presence of Plutonium by Iron(II) Reduction in Phosphoric Acid Followed by Chromium(VI) Titration
- [C1206](#) Test Method for Plutonium by Iron (II)/Chromium (VI) Amperometric Titration (Withdrawn 2015)⁷
- ~~[E1210](#)~~ ~~[C1233](#)~~ ~~Guide for Establishing a Measurement System Quality Control Program for Analytical Chemistry Laboratories Within the Nuclear Industry~~ ~~Practice for Determining Equivalent Boron Contents of Nuclear Materials~~
- [C1268](#) Test Method for Quantitative Determination of ²⁴¹Am in Plutonium by Gamma-Ray Spectrometry
- ~~[E1297](#)~~ ~~Guide for Qualification of Laboratory Analysts for the Analysis of Nuclear Fuel Cycle Materials~~
- [C1415](#) Test Method for ²³⁸Pu Isotopic Abundance By Alpha Spectrometry
- [C1432](#) Test Method for Determination of Impurities in Plutonium: Acid Dissolution, Ion Exchange Matrix Separation, and Inductively Coupled Plasma-Atomic Emission Spectroscopic (ICP/AES) Analysis
- [C1625](#) Test Method for Uranium and Plutonium Concentrations and Isotopic Abundances by Thermal Ionization Mass Spectrometry
- [C1637](#) Test Method for the Determination of Impurities in Plutonium Metal: Acid Digestion and Inductively Coupled Plasma-Mass Spectrometry (ICP-MS) Analysis
- [C1672](#) Test Method for Determination of Uranium or Plutonium Isotopic Composition or Concentration by the Total Evaporation Method Using a Thermal Ionization Mass Spectrometer
- [C1817](#) Test Method for The Determination of the Oxygen to Metal (O/M) Ratio in Sintered Mixed Oxide ((U, Pu)O₂) Pellets by Gravimetry
- [D1193](#) Specification for Reagent Water
- [D4327](#) Test Method for Anions in Water by Suppressed Ion Chromatography
- [E60](#) Practice for Analysis of Metals, Ores, and Related Materials by Spectrophotometry
- [E115](#) Practice for Photographic Processing in Optical Emission Spectrographic Analysis (Withdrawn 2002)⁷
- [E116](#) Practice for Photographic Photometry in Spectrochemical Analysis (Withdrawn 2002)⁷
- [E130](#) Practice for Designation of Shapes and Sizes of Graphite Electrodes (Withdrawn 2013)⁷

3. Terminology

3.1 Except as otherwise defined herein, definitions of terms are as given in Terminology [C859](#).

4. Significance and Use

4.1 Mixed oxide, a mixture of uranium and plutonium oxides, is used as a nuclear-reactor fuel in the form of pellets. The plutonium content may be up to 10 weight %, and the diluent uranium may be of any ²³⁵U enrichment. In order to be suitable for use as a nuclear fuel, the material must meet certain criteria for combined uranium and plutonium content, effective fissile content, and impurity content as described in Specification [C833](#).

4.1.1 The material is assayed for uranium and plutonium to determine whether the plutonium content is as specified by the purchaser, and whether the material contains the minimum combined uranium and plutonium contents specified on a dry weight basis.

4.1.2 Determination of the isotopic content of the plutonium and uranium in the mixed oxide is made to establish whether the effective fissile content is in compliance with the purchaser's specifications.

⁶ For referenced ASTM standards, visit the ASTM website, www.astm.org, or contact ASTM Customer Service at service@astm.org. For *Annual Book of ASTM Standards* volume information, refer to the standard's Document Summary page on the ASTM website.

⁷ The last approved version of this historical standard is referenced on www.astm.org.

4.1.3 Impurity content is determined to ensure that the maximum concentration limit of certain impurity elements is not exceeded. Determination of impurities is also required for calculation of the equivalent boron content (EBC):(EBC) as described in Practice [C1233](#).

4.2 *Fitness for Purpose of Safeguards and Nuclear Safety Applications*—Methods intended for use in safeguards and nuclear safety applications shall meet the requirements specified by Guide [C1068](#) for use in such applications.

5. Reagents

5.1 *Purity of Reagents*—Reagent grade chemicals shall be used in all tests. Unless otherwise indicated, it is intended that all reagents shall conform to the specifications of the Committee on Analytical Reagents of the American Chemical Society, where such specifications are available.⁸ Other grades may be used, provided it is first ascertained that the reagent is of sufficiently high purity to permit its use without lessening the accuracy of the determination.

5.2 *Purity of Water*—Unless otherwise indicated, references to water shall be understood to mean reagent water conforming to Specification [D1193](#).

6. Safety Precautions

6.1 Since plutonium- and uranium-bearing materials are radioactive and toxic, adequate laboratory facilities, ~~gloved glove~~ boxes, fume hoods, ~~etc., and so forth~~, along with safe techniques must be used in handling samples containing these materials. Glove boxes should be fitted with off-gas filters capable of sustained operation with dust-laden atmospheres. A detailed discussion of all the precautions necessary is beyond the scope of these test methods; however, personnel who handle these materials should be familiar with such safe handling practices as are given in Guide [C852](#) and in Refs ~~(1-3) through (2)~~.⁹

~~5.2 Committee C26 Safeguards Statement.~~⁹

~~5.2.1 The materials [nuclear grade mixed oxides (U, Pu)O₂ powders and pellets] to which these test methods apply are subject to nuclear safeguards regulations governing their possession and use. The following analytical procedures in these test methods have been designated as technically acceptable for generating safeguards accountability measurement data: Uranium by Controlled Potential Coulometry; Plutonium by Controlled-Potential Coulometry; Plutonium by Amperometric Titration with Iron(II); Plutonium-238 Isotopic Abundance by Alpha Spectrometry; and Uranium and Plutonium Isotopic Analysis by Mass Spectrometry.~~

~~5.2.2 When used in conjunction with appropriate certified reference materials (CRMs), these procedures can demonstrate traceability to the national measurements base. However, adherence to these procedures does not automatically guarantee regulatory acceptance of the resulting safeguards measurements. It remains the sole responsibility of the user of these test methods to assure that its application to safeguards has the approval of the proper regulatory authorities.~~

6.2 Adequate laboratory facilities, such as fume hoods and controlled ventilation, along with safe techniques, must be used in this procedure. Extreme care should be exercised in using hydrofluoric acid and other hot, concentrated acids. Use of proper gloves is recommended. Refer to the laboratory's chemical hygiene plan and other applicable guidance for handling chemical and radioactive materials and for the management of radioactive, mixed, and hazardous waste.

6.3 Hydrofluoric acid is a highly corrosive acid that can severely burn skin, eyes and mucous membranes. Hydrofluoric acid is similar to other acids in that the initial extent of a burn depends on the concentration, the temperature, and the duration of contact with the acid. Hydrofluoric acid differs from other acids because the fluoride ion readily penetrates the skin, causing destruction of deep tissue layers. Unlike other acids that are rapidly neutralized, hydrofluoric acid reactions with tissue may continue for days if left untreated. Due to the serious consequence of hydrofluoric acid burns, prevention of exposure or injury of personnel is the primary goal. Utilization of appropriate laboratory controls (hoods) and wearing adequate personal protective equipment to protect from skin and eye contact. Familiarization and compliance with the Safety Data Sheet is essential.

6.4 Perchloric acid (HClO₄) forms explosive compounds with organics and many metal salts. Avoid exposure by contact with the skin or eyes, or by inhalation of fumes. Familiarization and compliance with the Safety Data Sheet is essential. Carry out sample dissolution with perchloric acid in a fume hood with a scrubber unit that is specially designed for use with HClO₄.

7. Sampling and Dissolution

7.1 Criteria for sampling this material are given in Specification [C833](#).

7.2 Samples can be dissolved using the appropriate dissolution techniques described in Practice [C1168](#).

⁸ *Reagent Chemicals, American Chemical Society Specifications*, American Chemical Society, Washington, DC. For suggestions on the testing of reagents not listed by the American Chemical Society, see *Analar Standards for Laboratory Chemicals*, BDH Ltd., Poole, Dorset, U.K., and the *United States Pharmacopeia and National Formulary*, U.S. Pharmacopeial Convention, Inc. (USPC), Rockville, MD.

⁹ The boldface numbers in parentheses refer to the list of references at the end of these test methods.

URANIUM IN THE PRESENCE OF PLUTONIUM BY POTENTIOMETRIC TITRATION

(This test method was discontinued in 1992 and replaced by Test Method C1204.)

PLUTONIUM BY CONTROLLED POTENTIAL COULOMETRY

(This test method was discontinued in 1992 and replaced by Test Method C1165.)

PLUTONIUM BY CONTROLLED-POTENTIAL COULOMETRY

(With appropriate sample preparation, controlled-potential coulometric measurement as described in Test Method C1108 may be used for plutonium determination.)

PLUTONIUM BY AMPEROMETRIC TITRATION WITH IRON(II)

(This test method was discontinued in 1992 and replaced by Test Method C1206, which was withdrawn in 2015.)

NITROGEN BY DISTILLATION SPECTROPHOTOMETRY USING NESSLER REAGENT

8. Scope

8.1 This test method covers the determination of 5 to 100 µg/g of nitride nitrogen in mixtures of plutonium and uranium oxides in either pellet or powder form.

9. Summary of Test Method

9.1 The sample is dissolved in hydrochloric acid by the sealed tube test method or by phosphoric acid-hydrofluoric acid solution, after which the solution is made basic with sodium hydroxide and nitrogen is separated as ammonia by steam distillation. Nessler reagent is added to the distillate to form the yellow ammonium complex and the absorbance of the solution is measured at approximately 430 nm (34, 45).

10. Apparatus

10.1 *Distillation Apparatus* (see Fig. 1) for an example).

10.2 *Spectrophotometer*, visible-range.

11. Reagents

11.1 *Ammonium Chloride (NH₄Cl)*—Dry the salt for 2 h at 110 to 120°C.

11.2 *Boric Acid Solution (40 g/litre)*—Dissolve 40 g of boric acid (H₃BO₃) in 800 mL of hot water. Cool to approximately 20°C and dilute to 1 L.

11.3 *Hydrochloric Acid (sp gr 1.19)*—Concentrated hydrochloric acid (HCl).

11.4 *Hydrofluoric Acid (sp gr 1.15)*—Concentrated hydrofluoric acid (HF). See safety precaution in 6.3.

11.5 *Nessler Reagent*—To prepare, dissolve 50 g of potassium iodide (KI) in a minimum of cold ammonia-free water, approximately 35 mL. Add a saturated solution of mercuric chloride (HgCl₂, 22 g/350 mL) slowly until the first slight precipitate of red mercuric iodide persists. Add 400 mL of 9 N sodium hydroxide (NaOH) and dilute to 1 L with water. Mix, and allow the solution to stand overnight. Decant the supernatant liquid and store in a brown bottle.

11.6 *Nitrogen, Standard Solution (1 mL = 0.01 mg N)*—Dissolve 3.819 g of NH₄Cl in water and dilute to 1 L. Transfer 10 mL of this solution to a 1-L volumetric flask and dilute to volume with ammonia-free water.

11.7 *Sodium Hydroxide (9 N)*—Dissolve 360 g of sodium hydroxide (NaOH) in ammonia-free water and dilute to 1 L.

11.8 *Sodium Hydroxide Solution—(50 %)*—Dissolve NaOH in an equal weight of ammonia-free water.

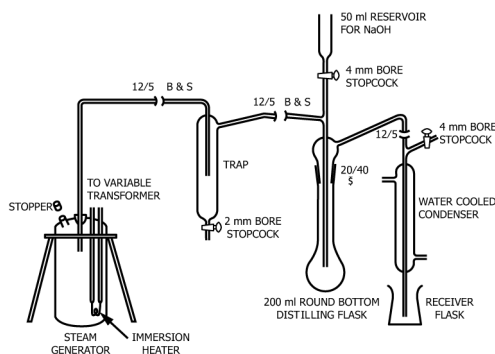

FIG. 1 Distillation Apparatus

11.9 *Water, Ammonia-Free*—To prepare, pass distilled water through a mixed-bed resin demineralizer and store in a tightly stoppered chemical-resistant glass bottle.

12. Precautions

12.1 The use of ammonia or other volatile nitrogenous compounds in the vicinity can lead to serious error. The following precautionary measures should be taken: (1) Clean all glassware and rinse with ammonia-free water immediately prior to use, and (2) avoid contamination of the atmosphere in the vicinity of the test by ammonia or other volatile nitrogenous compounds.

13. Procedure

13.1 *Dissolution of Sample:*

13.1.1 Transfer a weighed sample, in the range from 1.0 to 1.5 g, to a 50-mL beaker.

NOTE 1—Pellet samples should be crushed to a particle size of 1 mm or less with a diamond mortar.

13.1.2 Crush the pellet samples to a particle size of 1 mm or less in a diamond mortar.

13.1.3 To the sample add 5 mL of HCl (sp gr 1.19) and 3 drops of HF (sp gr 1.15). Heat to put the sample into solution.

NOTE 1—Concentrated phosphoric acid or mixtures of phosphoric acid and hydrofluoric acids or of phosphoric and sulfuric acids may be used for the dissolution of mixed oxide samples. Such acids may require a purification step in order to reduce the nitrogen blank before being used in this procedure.

13.2 *Distillation:*

13.2.1 Quantitatively transfer the sample solution to the distilling flask of the apparatus. Add 20 mL of ammonia-free water and then clamp the flask into place on the distillation apparatus (see Fig. 2) for an example).

13.2.2 Turn on the steam generator but do not close with the stopper.

13.2.3 Add 5 mL of boric acid solution (4 %) to a 50-mL graduated flask and position this trap so that the condenser tip is below the surface of the boric acid solution.

13.2.4 Transfer 20 mL of NaOH solution (50 %) to the funnel in the distillation head.

13.2.5 When the water begins to boil in the steam generator, replace the stopper and slowly open the stopcock on the distilling flask to allow the NaOH solution to run into the sample solution. (**Warning**—The NaOH solution must be added slowly to avoid a violent reaction, which may lead to a loss of sample.)

NOTE 3—The NaOH solution must be added slowly to avoid a violent reaction which may lead to loss of sample.

13.2.6 Steam distill until 25 mL of distillate has collected in the trap.

13.2.7 Remove the trap containing the distillate from the distillation apparatus, and remove the stopper from the steam generator.

13.2.8 Transfer the cooled distillate to a 50-mL volumetric flask.

13.2.9 Prepare a reagent blank solution by following steps 13.1.1 through 13.2.8.

13.3 *Measurement of Nitrogen:*

13.3.1 Add 1.0 mL of Nessler reagent to each of the distillates collected in 13.2.8 and 13.2.9. Dilute to volume with ammonia-free water, mix, and let stand for 10 min.

13.3.2 Measure the absorbance of the solutions at 430 nm in a 1-cm cell. Use water as the reference.

13.4 *Calibration Curve:*

13.4.1 Add 0, 5, 10, 25, 100, and 150 µg of nitrogen from the nitrogen standard solution to separate distilling flasks. Then, add 5 mL of HCl and 3 drops of HF plus 20 mL of ammonia-free water to each flask.

13.4.2 Process each solution by the procedure in 13.2 through 13.3 (omit step 13.2.9).

13.4.3 Correct for the reagent blank reading and plot the absorbance of each standard against micrograms of nitrogen per 50 mL of solution.

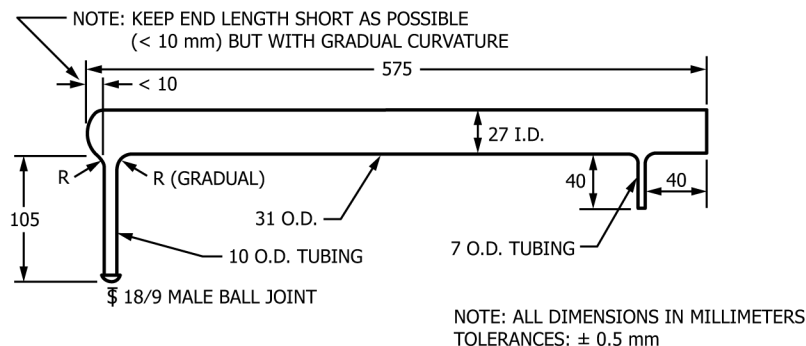

FIG. 2 Quartz Reaction Tube

14. Calculation

14.1 From the calibration chart, read the micrograms of nitrogen corresponding to the absorbance of the sample solution.

14.2 Calculate the nitrogen content of the sample as follows:

$$N, \mu\text{g/g} = (A - B)/W \quad (1)$$

where:

A = micrograms of nitrogen from sample plus reagents,

B = micrograms of nitrogen in blank, and

W = grams of sample.

15. Precision and Bias

15.1 The estimated relative standard deviation for a single measurement by this test method is 20 % for 3 μg of nitrogen and 3 % for 50 to 90 μg of nitrogen.

CARBON (TOTAL) BY DIRECT COMBUSTION-THERMAL CONDUCTIVITY

16. Scope

16.1 This test method covers the determination of 10 to 200 μg of residual carbon in nuclear grade mixed oxides, (U,Pu)O₂.

17. Summary of Test Method

17.1 Powdered samples are covered and mixed with an accelerator in carbon-free crucibles and burned with oxygen in an induction heating furnace. Traces of sulfur compounds and water vapor are removed from the combustion products by a purification train and the resultant carbon monoxide is converted to carbon dioxide. The purified carbon dioxide is trapped on a molecular sieve, eluted therefrom with a stream of helium upon application of heat to the trap, and passed through a thermal conductivity cell. The amount of carbon present, being a function of the integrated change in the current of the detector cell, is read directly from a calibrated-digital voltmeter or strip-chart recorder.

18. Interferences

18.1 There are no known interferences not eliminated by the purification system.

19. Apparatus

19.1 *Commercial Combustion Apparatus*, suitable for the carbon determination, is often modified to facilitate maintenance and operation within the glove box which is required for all work with plutonium materials.

19.2 *Combustion Apparatus*, consisting of an induction furnace, suitable for operation at 1600°C, a catalytic furnace, a purification train, a carbon dioxide trap, thermal conductivity cell with appropriate readout equipment, and a regulated supply of oxygen and helium.

19.3 *Combustion Tubes*—Quartz combustion tubes with integral baffle shall be used.

19.4 *Crucibles*—Expendable alumina or similar refractory crucibles shall be used. The use of crucible covers is optional. Satisfactory operation with covers must be established by analysis of standards. Crucibles and covers (if used) must be ignited at a temperature of 1000°C or higher for a time sufficient to produce constant blank values.

19.5 *Accelerators*—Granular tin, copper, iron, and copper oxide accelerators shall be used to obtain satisfactory results. The criterion for satisfactory results is the absence of significant additional carbon release upon recombustion of the specimen.

19.6 *Catalytic Furnace and Tube*—This unit, which is used to ensure complete conversion of CO to CO₂, consists of a tube containing copper oxide and maintained at a temperature of 300°C by a small furnace.

19.7 *Carbon Dioxide Purifiers*—The purifiers that follow the combustion tube must remove finely divided solid metallic oxides and oxides of sulfur and selenium, dry the gases before they enter the CO₂ trap, and protect the absorber from outside effects. Finely divided solid metal oxides are removed from the gases during their passage through the quartz wool. The SO₂ given off by materials containing sulfur is removed by MnO₂ and any water vapor is absorbed in a tube containing Mg(ClO₄)₂. Hot copper oxide converts carbon monoxide to carbon dioxide. Additional components in the purification train may be required when materials containing very high amounts of sulfur or of halides are being analyzed. The materials used in the purification train must be checked frequently to ensure that their absorbing capacity has not been exhausted.

19.8 *Vibratory Sample Pulverizer Apparatus*, capable of reducing ceramic materials to a —100-mesh powder such that 90 % or more of the particles are less than 149 μm (equivalent to a — 100-mesh powder). A stainless steel capsule and mixing ball must be used, in order to reduce contamination of the sample with carbon.

20. Reagents and Materials

20.1 *Quartz Wool*, used as a dust trap at the top of the combustion tube.

20.2 *Sulfuric Acid (H_2SO_4 , sp gr 1.84)*, used in the oxygen purification train.

20.3 *Standard Materials*—Certified reference material standards from a national standards body such as the U.S. National Institute for Standards and Technology (NIST) SRMs 131e (0.0029 % carbon) and 336 (0.567 % carbon) or their replacements or equivalent. Certified materials in steel matrices (steel pins steel rings, steel granules, and steel powder) ranging from 5 μg carbon/g sample to 1500 μg carbon/g sample are available and have been found satisfactory.

20. Safety Precautions

20.1 *Samples Containing Plutonium*—Due to the extreme toxicity of plutonium and the certainty that some plutonium will become airborne during the analytical operations, it is mandatory to perform all operations within an approved glove box fitted with off-gas filters capable of sustained operation with dust-laden atmospheres.

20.2 *Samples Containing Uranium*—Natural or depleted uranium presents a somewhat less serious toxicological hazard than plutonium, but operations should be conducted in a fume hood with adequate ventilation, as a minimum precaution.

21. Sampling and Preparation

21.1 *Sample Size*—The normal size for mixed oxide [(U,Pu) O_2] fuel materials shall be 1 g. If necessary, this amount shall be altered as required to contain less than 200 μg of carbon.

21.2 *Sample Preparation*—Pellet or particulate samples shall be reduced to approximately 100-mesh powders such that approximately 90 % of the particles are less than 149 μm (equivalent to approximately 100-mesh powder) prior to the weighing of the specimens. Exposure of the powdered sample to atmospheric carbon dioxide should be minimized by storage of the powder in a closed vial.

22. Preparation of Apparatus

22.1 *Analysis System Purge*—After having properly set the operating controls of the instrument system, condition the apparatus by combustion of several blanks prepared with the sample crucible and accelerator in the amount to be used with the test specimen analyses. Successive blank values should approach a constant value, allowing for normal statistical fluctuations. The instrument should be adjusted for a 2-min combustion period.

23. Calibration

23.1 *Preparation of Standards for Combustion*—Mix a weighed portion of an accelerator and an accurately weighed portion of approximately 1 g of NIST 131e Low-Carbon Steel reference material with a certified carbon value of about 0.005 % in each of the three sample crucibles. Repeat with NIST SRM 336 or a reference material with a certified carbon value of about 0.5 % (Note 42), using an accurately weighed portion of approximately 30 to 40 mg.

NOTE 2—The NIST SRM 336 steel is assigned a carbon content of 0.567 % (5670 $\mu\text{g}/\text{g}$). Therefore, amounts ranging up to approximately 40 mg are used for standardization. Weigh the steel into a tared container (a small nickel sample boat if convenient), obtaining the mass to the nearest 0.01 mg. Transfer the chips to a 30-mm-square of aluminum foil (previously acetone washed), and fold the foil into a wrapper with the aid of stainless steel tongs and spatulas. The foil should not be touched by the hands. Place the wrapped standard in a numbered glass sample vial and transfer to the analyzer glove box. These portions represent about 50 μg and 200 μg of carbon, respectively.

23.1.1 Weigh the steel into a tared container, such as a small nickel sample boat, obtaining the mass to the nearest 0.01 mg. Transfer the chips to a 30-mm square of aluminum foil (previously acetone washed), and fold the foil into a wrapper with the aid of stainless steel tongs and spatulas. The foil should not be touched by the hands. Place the wrapped standard in a numbered glass sample vial and transfer to the analyzer glove box.

23.2 *Combustion of Standards*—Load and combust the standards and record the results. Adjust the calibration controls in such a way as to produce the correct readout value on the direct readout meter. Combust additional standards as required to produce the correct direct readout. As an alternative, consider the readout digits as arbitrary numbers and prepare a calibration curve of known micrograms of carbon versus readout value. A strip chart recorder connected to present the integrated value of the carbon dioxide response signal is helpful in detecting and correcting for analyzer drift and noise.

24. Procedure

24.1 Pulverize the pellet samples for 15 s in the stainless steel capsule of the sample pulverizer.

24.2 Weigh a sample crucible containing the required amount of accelerator to the nearest 0.01 g.

24.3 Transfer the sample powder, not to exceed 1 g or of such size as to give not more than 200 μg of carbon, to the crucible. Weigh the crucible and contents to the nearest 0.01 g and find the specimen mass by difference.

24.4 Mix the specimen powder and the accelerator with a stainless steel spatula.

24.5 Load the sample crucible into the furnace and combust the specimen for 2 min.

24.6 Remove the sample crucible and examine it for evidence of incomplete combustion. The crucible contents should be a uniform fused mass.

25. Calculation

25.1 Calculate the concentration of carbon in the sample by dividing the net micrograms of carbon found by the sample mass expressed in grams as follows:

$$C, \mu\text{g/g} = (C_s - C_b)/W \tag{2}$$

where:

C_s = carbon in sample and reagents, μg ,

C_b = carbon in reagent blank, μg , and

W = grams of mixed oxide sample.

26. Precision and Bias

26.1 *Precision*—The average standard deviation for a single measurement from the results of six laboratories is on the order of $10\mu\text{g}$ carbon/g of sample.

26.2 *Bias*—The results obtained by six laboratories participating in a recent comparative analytical program averaged 85 % of the expected $100\mu\text{g/g}$ of carbon in the sample. The incomplete recovery is thought to represent a lack of experience on the part of two laboratories inasmuch as 95 to 100 % recovery was obtained by three of the participating laboratories.

TOTAL CHLORINE AND FLUORINE BY PYROHYDROLYSIS

27. Scope

27.1 This test method is applicable to the determination of 5 to $100\mu\text{g/g}$ of chlorine and 1 to $100\mu\text{g/g}$ of fluorine in 1-g samples of nuclear-grade mixed oxides, (U, Pu) O_2 .

28. Summary of Test Method

28.1 A 1 to 2-g sample of the mixed oxide is pyrohydrolyzed at 950°C with a stream of moist air or oxygen. The halogens are volatilized as acids during the pyrohydrolysis and are trapped as chloride and fluoride in a buffered solution. Several procedures are outlined for the measurement of chloride and fluoride in the resultant condensate. Chloride is measured by spectrophotometry, microtitrimetry, or with ion-selective electrodes and fluoride with ion-selective electrodes or spectrophotometry (5-(66-9)).

29. Interferences

29.1 Bromide, iodide, cyanide, sulfide, and thiocyanate, if present in the condensate, would interfere with the spectrophotometric and microtitrimetric measurement of chloride. Bromide, iodide, sulfide, and cyanide interfere in the measurement of chloride with ion-selective electrodes, but have very little effect upon the measurement of fluoride with selective electrodes.

30. Apparatus (See Fig. 2 and Fig. 3 and for Fig. 2) examples)

30.1 *Gas-Flow Regulator*—A flowmeter and a rate controller are required to adjust the flow of sparge gas between 1 to 3 L/min.

30.2 *Hot Plate*—A heater used to keep the water bubbler temperature between 50 and 90°C is required.

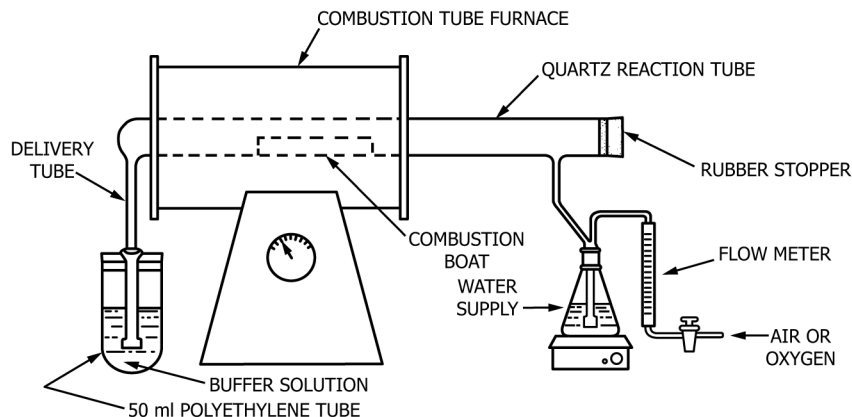

FIG. 3 Pyrohydrolysis Apparatus

30.3 *Furnace*—A tube furnace is required that is capable of maintaining a temperature from 900 to 1000°C. The bore of the furnace should be about 32 mm ($\pm 1.25\frac{1}{4}$ in.) in diameter and about 305 mm (12 in.) in length.

30.4 *Reactor Tube*, made from fused-silica or platinum. The delivery tube should be a part of the exit end of the reactor tube and be within 51 mm (2 in.) of the furnace. (See Fig. 3 for proper tube positioning.)

30.5 *Combustion Boats*, made from fused-silica or platinum. A boat about 102 mm (4 in.) long is made by cutting lengthwise a 20-mm diameter silica tube and flattening one end to provide a handle. A fused-silica inner sleeve for the reactor tube can facilitate the movement of the boat into the tube, prevent spillage, and thus prolong the life of the combustion tube.

30.6 *Collection Vessel*—A plastic graduate or beaker designed to maintain most of the scrubber solution above the tip of the delivery tube is required.

30.7 *Automatic Chloride Titrator*.

30.8 *Ion-selective Electrodes*, chloride and fluoride.

30.9 *Reference Electrode*—Use a double-junction type such as mercuric sulfate, sleeve-junction type electrode. Do not use a calomel electrode.

30.10 *Spectrophotometer*—Ultraviolet to visible range and absorption cells. For a discussion on spectrophotometers and their use see Practice E60.

30.11 *Meter, pH*, with expanded scale with a sensitivity of 1 mV.

31. Reagents

31.1 *Accelerator (U_3O_8)*—Halogen free U_3O_8 powder used as a flux to enhance the release of chloride and fluoride.

31.2 *Air or Oxygen*, compressed.

31.3 *Buffer Solution (0.001 N Acetic Acid, 0.001 N Potassium Acetate)*—Prepare by adding 50 μ L of glacial acetic acid (CH_3CO_2H , sp gr 1.05) and 0.10 g of potassium acetate ($KC_2H_3O_2$) to 1 L of water.

31.4 *Chloride Standard Solution (1 mL = 1 mg Cl)*—Dissolve 1.65 g of sodium chloride (NaCl) in water and dilute to 1 L.

31.5 *Chloride Standard Solution (1 mL = 5 μ g Cl)*—Prepare by diluting 5 mL of chloride solution (1 mL = 1 mg Cl) to 1 L with water.

31.6 *Ferric Ammonium Sulfate (0.25 M in 9 M Nitric Acid)*—Dissolve 12 g of $FeNH_4(SO_4)_2 \cdot 12 H_2O$ in 58 mL of concentrated nitric acid (HNO_3 , sp gr 1.42) and dilute to 100 mL with water.

31.7 *Fluoride, Standard Solution (1 mL = 1 mg F)*—Dissolve 2.21 g of sodium fluoride (NaF) in water and dilute to 1 L.

31.8 *Fluoride, Standard Solution (1 mL = 10 μ g F)*—Dilute 10 mL of fluoride solution (1 mL = 1 mg F) to 1 L with water.

31.9 *Gelatin Solution*—Add 6.2 g of dry gelatin mixture (60 parts of dry gelatin + 1 part of thymol blue + 1 part of thymol) to 1 L of hot water and heat while stirring until the solution is clear.

31.10 *Lanthanum-Alizarin Complexone*—Dissolve 0.048 g of alizarin complexone (3-aminomethylalizarin-*N,N*-diacetic acid) in 100 μ L of concentrated ammonium hydroxide, 1 mL of an ammonium acetate solution ($NH_4C_2H_3O_2$, 20 mass %), and 5 mL of water. Filter the solution through high grade, rapid filter paper. Wash the paper with a small volume of water and add 8.2 g of anhydrous sodium acetate ($NaC_2H_3O_2$) and 6 mL of CH_3CO_2H (sp gr 1.05) to the filtrate. Add 100 mL of acetone while swirling the filtrate. Add 0.040 g of lanthanum oxide (La_2O_3) dissolved in 2.5 mL of warm 2 N HCl. Mix the two solutions and dilute to 200 mL. After 30 min readjust the solution volume.

NOTE 3—A 0.1-g/L solution of Amadeo-F is prepared by dissolving 100 mg of the reagent in water and diluting with isopropyl alcohol to obtain a 60 % alcoholic medium.

31.11 *Mercuric Thiocyanate Solution*—Prepare a saturated solution by adding 0.3 g of mercuric thiocyanate [$Hg(SCN)_2$] to 100 mL of ethanol (95 %). Shake the mixture thoroughly for maximum dissolution of the solid. Filter the solution.

31.12 *Nitric Acid-Acetic Acid Solution (1 N nitric acid and 4 N acetic acid)*—Prepare by adding 64 mL of nitric acid (HNO_3 , sp gr 1.42) to a 1-L volumetric flask which contains 500 mL of water. Swirl the solution in the flask and add 230 mL of CH_3CO_2H (sp gr 1.05). Dilute the solution with water to 1 L.

32. Pyrohydrolysis Procedure

32.1 Prepare the pyrohydrolysis apparatus for use as follows:

32.1.1 Regulate the gas flow between 1 and 3 L/min.

32.1.2 Adjust the temperature of the hot plate to heat the water to approximately 90°C.

32.1.3 Adjust the temperature of the furnace to $950 \pm 50^\circ C$.

32.1.4 Add 15 mL of buffer solution to the collection vessel and place around the delivery tube.

32.2 Weigh accurately 1 to 2 g of the powdered mixed oxide and transfer to a combustion boat. If an accelerator, U_3O_8 , is used, mix 4 g with the sample before loading the powdered mixed oxide into the boat.

32.3 Place the boat containing the sample into the reactor tube and quickly close the tube. The boat should be in the middle of the furnace.

32.4 Allow the pyrohydrolysis to proceed for at least 30 min.

32.5 Remove the collection vessel and wash down the delivery tube with some buffer solution. Dilute the solution to 25 mL with the acetate buffer. Determine the chloride and fluoride by one or more of the measurement procedures covered in Section ~~3360~~ [3360](#).

32.6 Remove the boat from the reactor tube and dispose of the sample residue.

32.7 Run a pyrohydrolysis blank with halogen-free U_3O_8 by following the procedure in [32.3](#) through [32.6](#).

33. Measurement of Chloride and Fluoride

33.1 *Determination of Chloride by Spectrophotometry:*

33.1.1 Prepare a calibration curve by adding 0, 1, 2, 5, and 10 mL of chloride standard solution (1 mL = 5 μ g Cl) to separate 25-mL flasks. Dilute each to 20 mL with the buffer solution, add 2 mL of ferric ammonium sulfate solution and 2 mL of mercuric thiocyanate reagent. Mix the solution and dilute to 25 mL with water. Mix the solutions again and allow them to stand 10 min. Transfer some of the solution from the flask to a 1-cm absorption cell and read the absorbance at 460 nm using water as the reference liquid. Plot the micrograms of chloride per 25 mL *versus* the absorbance reading.

33.1.2 To determine the chloride in the pyrohydrolysis condensate transfer 15 mL of buffer solution to a 25-mL volumetric flask. Add 2 mL of ferric ammonium sulfate solution and 2 mL of mercuric thiocyanate solution. Mix the solutions, dilute to volume with water, and mix again. Allow the solution to stand 10 min. Transfer some of the solution from the flask to a 1-cm absorption cell and read the absorbance at 460 nm *versus* water as the reference. Read the micrograms of chloride present from the calibration curve.

NOTE 4—A calibration curve can be prepared by drying measured aliquots of a standard chloride solution on some halogen-free U_3O_8 and proceeding through pyrohydrolysis steps.

33.1.3 Calculate the chlorine as follows:

$$Cl, \mu g/g = [(A - B)/W] (V_1/V_2) \quad (3)$$

where:

A = micrograms of chlorine in aliquot measured,

B = micrograms of chlorine in blank,

W = grams of mixed oxide pyrohydrolyzed,

V_1 = millilitres of scrub solution, and

V_2 = aliquot in millilitres of scrub solution analyzed.

33.2 *Determination of Chloride by Amperometric Microtitrimetry:*

33.2.1 Calibrate the titrator by adding 5 mL of buffer solution, 1 mL of nitric acid-acetic acid solution, and 2 drops of the gelatin solution to a titration cell. Pipet 50 μ L of the chloride standard solution (1 mL = 1 mg Cl) into the titration cell. Place the cell on the chloride titrator and follow the manufacturer's suggested sequence of operations for titrating chloride. Record the time required to titrate 50 μ g. Run a reagent blank titration.

NOTE 5—The chloride analyzer generates silver ions which react to precipitate the chloride ion. The instrument uses an amperometric end point to obtain an automatic shut-off of the generating current at a pre-set increment of indicator current. Since the rate of generating silver ion is constant, the amount of chloride precipitated is proportional to the time required for the titration.

33.2.2 Determine the chloride in the pyrohydrolysis scrub solution by adding 5 mL to a titration cell which contains 1 mL of the nitric acid-acetic acid solution and 2 drops of the gelatin solution.

33.2.3 Place the cell in position on the titrator. Start the titrator and record the time required to titrate the chloride present.

33.2.4 Calculate the chlorine as follows:

$$Cl, \mu g/g = V_1 F (T_s - T_B) / V_2 W \quad (4)$$

where:

V_1 = volume of scrub solutions = 25,

V_2 = aliquot, in millilitres, of scrub solution analyzed,

F = micrograms of Cl standard titrated/titration time of standard – titration time of blank or

$F = 50 / (T_{Cl} - T_B)$,

T_s = titration time to titrate sample and blank,

T_{Cl} = titration time to titrate 50 μ g Cl and blank,

T_B = titration time to titrate reagent blank, and

W = grams of mixed oxide pyrohydrolyzed.

33.3 Determination of Chloride and Fluoride With Ion-Selective Electrodes:

33.3.1 Preparation of the calibration curves requires the assembly of the meter and the ion-selective electrode with a suitable reference electrode. From these standards take the millivolt readings for each ion-selective electrode and ~~plot on semi-log paper~~ determine the halogen content per 25 mL versus millivolts, using computer software or a plot on semi-log paper. Prepare a series of standards in acetate buffer solution by pipeting aliquots of the halogen standards into separate 25-mL flasks ranging in concentrations as follows:

chloride 10 to 100 $\mu\text{g}/25$ mL
fluoride 5 to 100 $\mu\text{g}/25$ mL

33.3.2 Determine the chloride and fluoride in the scrub solution from the pyrohydrolysis by using the appropriate ion-selective electrode. Record the micrograms of chloride or fluoride from the calibration curve and calculate the halide as follows:

$$\text{Cl or F, } \mu\text{g/g} = (H_s - H_b)/W \quad (5)$$

where:

H_s = micrograms of halide in aliquot of scrub solution plus blank,

H_b = micrograms of halide in pyrohydrolysis blank, and

W = grams of sample.

33.4 Determination of Fluoride by Spectrophotometry:

33.4.1 Prepare a calibration curve by adding to separate 10-mL flasks 0, 50, 100, 200, 500, and 1000 μL of fluoride standard solution (1 mL = 10 μg F). Add 2.0 mL of lanthanum-alizarin complexone solution and dilute to volume with water. Mix and let stand 1 h. Read the absorbance at 622 nm *versus* the reagent blank. Plot the micrograms of fluoride per 10 mL *versus* the absorbance reading.

33.4.2 Measure the fluoride in the pyrohydrolysis scrub solution by pipeting 5 mL into a 10-mL volumetric flask. Add 2.0 mL of lanthanum-alizarin complexone and dilute to volume. Mix and let stand 1 h. Read the absorbance at 622 nm *versus* a reagent blank and obtain the fluoride content from the calibration curve.

33.4.3 Calculate the fluorine concentration in the mixed oxide sample as follows:

$$\text{F, } \mu\text{g/g} = [(F_s - F_b)/W] \times (V_1/V_2) \quad (6)$$

where:

F_s = fluorine in aliquot of scrub solution plus the blank, μg ,

F_b = fluorine in pyrohydrolysis blank, μg ,

V_1 = total volume of the scrub solution, mL,

V_2 = aliquot of scrub solution analyzed, mL, and

W = grams of mixed oxide sample.

33.5 Determination of Chloride and Fluoride by Ion Chromatography—Determine the Cl and F in the scrub solution from the pyrohydrolysis in accordance with Test Method D4327. Record the micrograms of Cl or F from the calibration curve and calculate the halide using Eq 5.

34. Precision and Bias

34.1 The relative standard deviations for the measurements of fluorine are approximately 7 % for the 5 to 50- $\mu\text{g}/\text{g}$ range and 10 % for the 1 to 5- $\mu\text{g}/\text{g}$ range. The relative standard deviations for the measurements of chlorine vary from 5 % at the 5 to 50- $\mu\text{g}/\text{g}$ level and up to 10 % below the 5- $\mu\text{g}/\text{g}$ range.

SULFUR BY DISTILLATION-SPECTROPHOTOMETRY

35. Scope

35.1 This test method covers the determination of sulfur in the concentration range from 10 to 600 $\mu\text{g}/\text{g}$ for samples of nuclear-grade uranium and plutonium mixed oxides, (U, Pu) O_2 .

36. Summary of Test Method

36.1 Sulfur is measured spectrophotometrically as Lauth's Violet following its separation by distillation as hydrogen sulfide (710). Higher oxidation states of sulfur are reduced to sulfide by a hypophosphorous-hydriodic acid mixture, the hydrogen sulfide is distilled into zinc acetate, and *p*-phenylenediamine and ferric chloride are added to form Lauth's Violet. The quantity of sulfur is calculated from the measured absorbance at 595 nm and the absorbance per microgram of sulfur obtained for calibration materials having known sulfur contents. The relative standard deviation ranges from 12 to 3 % for the concentration range from 10 to 600 μg of sulfur per gram of sample.

37. Interference

37.1 None of the impurity elements interfere when present in amounts up to twice their specification limits for uranium and plutonium mixed oxides.

38. Apparatus

38.1 *Boiling Flask*, adapted with a gas inlet line and fitted with a water-cooled condenser and delivery tube.

38.2 *Spectrophotometer*, with matched 1-cm cells.

38.3 *Sulfur Distillation Apparatus*—see Fig. 4: for example.

39. Reagents

39.1 *Argon Gas*, cylinder.

39.2 *Ferric Chloride Solution*, 2 % ferric chloride (FeCl_3) in 6 M HCl.

39.3 *Formic Acid*, redistilled.

39.4 *Hydriodic-Hypophosphorous Acid Reducing Mixture*—Mix 400 mL of 47 % hydriodic acid (HI) with 200 mL of hypophosphorous acid (H_3PO_2) (31 %) and boil under reflux for 30 min with a continuous argon sparge. Test for the sulfur content by analyzing a 15-mL aliquot as described in the procedure. Reboil if necessary to reduce the sulfur content to below 1 $\mu\text{g/mL}$.

39.5 *Hydrochloric Acid (0.6 M)*—Dilute 10 mL of 12 M hydrochloric acid (HCl) to 200 mL with water.

39.6 *Hydrochloric Acid (3 M)*—Dilute 50 mL of 12 M HCl to 200 mL with water.

39.7 *Hydrochloric Acid (6 M)*—Dilute 100 mL of 12 M HCl to 200 mL with water.

39.8 *Hydrochloric Acid (12 M)*—Analyze an aliquot of HCl (sp gr 1.19) for sulfur content. Use only a reagent in which the sulfur content is less than 1 $\mu\text{g}/10$ mL and prepare the diluted acids with this reagent.

39.9 *Hydrofluoric Acid (HF)*, (sp gr 1.15)—Concentrated hydrofluoric acid (HF). See safety precaution in 6.3.

39.10 *Hydroxylamine Hydrochloride* ($\text{NH}_2\text{OH}\cdot\text{HCl}$), 20 % aqueous solution.

39.11 *Nitric Acid (HNO_3) (15.6 M)*, 70 %.

39.12 *p-Phenylenediamine (1 %)*—Dissolve 1 g of *p*-phenylenediamine in 100 mL of 0.6 M HCl.

39.13 *Silver Nitrate (AgNO_3)*, 1 % aqueous solution.

39.14 *Sulfur Calibration Solution (1 mL = 5 $\mu\text{g S}$)*—Dissolve 2.717 g of dry potassium sulfate (K_2SO_4) in water and dilute to 1 L. Dilute 2.00 mL to 200 mL with water.

39.15 *Zinc Acetate Solution (4 %)*—Dissolve 20 g of zinc acetate [$\text{Zn}(\text{C}_2\text{H}_3\text{O}_2)_2$] in 500 mL of water and filter.

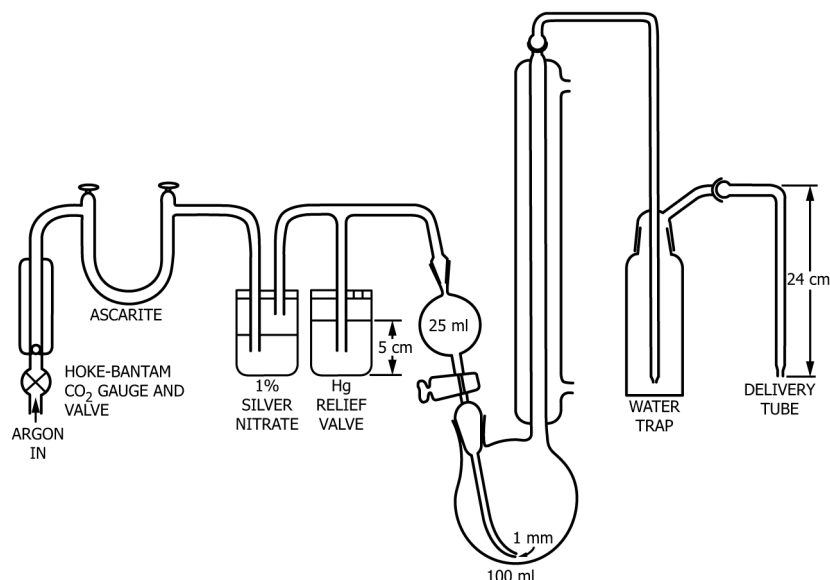

FIG. 4 Sulfur Distillation Apparatus