



Designation: ~~D4158 – 08 (Reapproved 2012)~~ **D4158 – 08 (Reapproved 2016)**

Standard Guide for Abrasion Resistance of Textile Fabrics (Uniform Abrasion)¹

This standard is issued under the fixed designation D4158; the number immediately following the designation indicates the year of original adoption or, in the case of revision, the year of last revision. A number in parentheses indicates the year of last reappraisal. A superscript epsilon (ϵ) indicates an editorial change since the last revision or reappraisal.

This standard has been approved for use by agencies of the U.S. Department of Defense.

1. Scope

1.1 This guide covers the determination of the resistance to abrasion of a wide range of textile materials using the uniform abrasion testing instrument. Fabrics of all types including carpets, garments and nonwovens may be tested under this method.

NOTE 1—Other procedures for measuring the abrasion resistance of textile fabrics are given in: Test Methods [D3884](#), [D3885](#), [D3886](#), [D4157](#), [D4966](#), and AATCC Test Method 93.

1.1.1 Provisions are provided for testing specimens in dry and wet conditions. Four options for evaluation are included:

- Option 1—Fabric Rupture
- Option 2—Mass Loss
- Option 3—Thickness Loss
- Option 4—Breaking Strength Loss

1.1.2 Provision is provided for testing specimens in the wet state.

1.2 The values stated in either SI units or inch-pound units are to be regarded separately as the standard. Within the text, the inch-pound units are shown in parentheses. The values stated in each system may not be exact equivalents; therefore, each system shall be used independently of the other. Combining values from the two systems may result in nonconformance with the specification.

1.3 *This guide does not purport to address all of the safety concerns, if any, associated with its use. It is the responsibility of the user of this standard to establish appropriate safety and health practices and determine the applicability of regulatory limitations prior to use.*

2. Referenced Documents

2.1 *ASTM Standards:*²

- [D123 Terminology Relating to Textiles](#)
- [D1776 Practice for Conditioning and Testing Textiles](#)
- [D3884 Guide for Abrasion Resistance of Textile Fabrics \(Rotary Platform, Double-Head Method\)](#)
- [D3885 Test Method for Abrasion Resistance of Textile Fabrics \(Flexing and Abrasion Method\)](#)
- [D3886 Test Method for Abrasion Resistance of Textile Fabrics \(Inflated Diaphragm Apparatus\)](#)
- [D4157 Test Method for Abrasion Resistance of Textile Fabrics \(Oscillatory Cylinder Method\)](#)
- [D4850 Terminology Relating to Fabrics and Fabric Test Methods](#)
- [D4966 Test Method for Abrasion Resistance of Textile Fabrics \(Martindale Abrasion Tester Method\)](#)
- [D5035 Test Method for Breaking Force and Elongation of Textile Fabrics \(Strip Method\)](#)

2.2 *Other Documents:*

- [AATCC Test Method 93 Abrasion Resistance of Fabrics: Accelerator Method](#)³

3. Terminology

3.1 For all terms relating to D13.60, Fabric Test Methods, Specific, refer to Terminology [D4850](#).

3.1.1 The following terms are relevant to this standard: abrasion, abrasion cycle, rotation.

¹ This guide is under the jurisdiction of ASTM Committee [D13](#) on Textiles and is the direct responsibility of Subcommittee [D13.60](#) on Fabric Test Methods, Specific. Current edition approved July 1, 2012/July 1, 2016. Published August 2012/July 2016. Originally approved in 1982. Last previous edition approved in 2008/2012 as [D4158 – 08: D4158 – 08 \(2012\)](#). DOI: [10.1520/D4158-08R12.10.1520/D4158-08R16](#).

² For referenced ASTM standards, visit the ASTM website, [www.astm.org](#), or contact ASTM Customer Service at [service@astm.org](#). For *Annual Book of ASTM Standards* volume information, refer to the standard's Document Summary page on the ASTM website.

³ Available from American Association of Textile Chemists and Colorists (AATCC), P.O. Box 12215, Research Triangle Park, NC 27709, [http://www.aatcc.org](#).

3.2 For all other terminology related to textiles, see Terminology **D123**.

4. Summary of Test

4.1 A specimen is mounted in a holder and abraded uniformly in all directions in the plane and about every point of the surface of the specimen. The settings of the instrument, method of mounting specimens, conditions of test (conditioned or wet), and criteria to be used in evaluating abrasive wear in the test, depend upon the nature of the specimen to be tested and the use to be made of the test results. Abrasion resistance for wear is evaluated by one or more conditions of destruction, a defined surface damage, loss in the mass, strength or thickness of test specimens, or by increased weakness in the sample as shown by a subsequent test by another method, depending on the material or its intended use.

5. Significance and Use

5.1 The resistance to abrasion of textile materials is affected by many factors in a complex manner. The results obtained from the use of this instrument assist in evaluating these factors relative to the wear serviceability of the final textile product in specific end uses. The resistance to abrasion is affected by many factors that include the inherent mechanical properties of the fibers; the dimensions of the fibers; the structure of the yarns; the construction of the fabrics; the type, kind, amount of treatment added to the fibers, yarns or fabric; the nature of the abradant; the tension on the specimen; the pressure between the specimen and the abradant; and the dimensional changes in the specimen. Experience has shown in many instances, that relative results obtained with this instrument when used on a series of fabrics, agreed with those obtained based upon performance in end use. However, caution is advised because anomalous results may occur due to uncontrolled factors in manufacturing or other processes. Specific instances have been described.^{4,5,6,7} In any event, anomalous results should be studied to further understand the complex behavior that may occur as a result of abrasion that may in turn assist in the development of more durable fabrics.

5.2 Testing some specimens under “wet” conditions can add another dimension to the evaluation of some textiles. Such testing under “wet” conditions can help ascertain the effect of changes in a fabric’s resistance to abrasion when it becomes wet. This test can also increase the uniformity of the abrading action by washing away abrasion debris and preventing the build up of broken fibers that can interfere with the proper progression of the tests.

5.3 This test is used as a guide in evaluating textiles in quality control and in research.

5.3.1 If there are differences of practical significance between reported test results for two laboratories (or more), comparative tests should be performed to determine if there is a statistical bias between them, using competent statistical assistance. As a minimum, the test samples should be used that are as homogenous as possible, that are drawn from the material from which the disparate test results were obtained, and that are randomly assigned in equal numbers to each laboratory for testing. Other fabrics with established test values may be used for this purpose. The test results from the two laboratories should be compared using a statistical test for unpaired data, at a probability level chosen prior to the testing series. If a bias is found, either a cause must be found and corrected, or future test results must be adjusted in consideration of the known bias.

5.4 This test is unique and is significantly different from any other existing abrading test.[cdnaa73/astm-d4158-082016](https://cdnaa73.astm-d4158-082016)

5.5 This guide may also be used as a technique for pretreating material for subsequent testing. For example, a predetermined number of abrasion cycles at specified test conditions may be performed on a series of specimens, which are then subjected to a strength or barrier performance test.

5.6 The resistance of textile materials to abrasion as measured by this guide does not include all the factors which account for wear performance or durability in actual use. While the “abrasion resistance” stated in terms of the number of cycles and “durability” (defined as the ability to withstand deterioration or wearing out in use, including the effects of abrasion) are frequently related. The relationship varies with different end uses, and different factors may be necessary in any calculation of predicted durability from specific abrasion data.

5.6.1 Laboratory tests may be reliable as an indication of relative end-use suitability in cases where the difference in abrasion resistance of various materials is large, but they should not be relied upon for prediction of performance during actual wear life for specific end uses unless there are data showing the specific relationship between laboratory abrasion tests and actual wear in the intended end use.

5.7 The pressure and tension used is varied, depending on the mass and nature of the material and the end use application. Whenever possible all materials that are to be compared with each other should be tested under the same pressure and tension.

⁴ Schiefer, H. F. and Krasny, J. F., “Note on the Disintegration of Wool in Abrasion Tests,” *Textile Research Journal*, Vol 19, January 1950, pp. 802–809; *Journal of Research*, Nat. Bureau Standards, Vol 44, January 1950, pp. 9–14 (*Research Paper RP 2054*).

⁵ Schiefer, H. F., Crean, L. E. and Krasny, J. F. “Improved Single-Unit Schiefer Abrasion Testing Machine,” *Journal of Research*, Nat. Bureau Standards, Vol 42, May, 1949, pp. 259–269. *ASTM Bulletin*, No. 159, July 1949, pp. 73–78 (*TP133*).

⁶ Schiefer, H. F., “Solution of Problem Producing Uniform Abrasion and its Application to the Testing Machine,” *Journal of Research*, Nat. Bureau of Standard Vol. 39, July 1947 (*Research Paper R1807*).

⁷ Schiefer, H. F., and Wertz, C. W., “Interpretation of Tests for Resistance to Abrasion of Textiles,” *Textile Research Journal*, Vol XXII No. 1, January 1952.

5.8 When abrasion tests are continued to total destruction, abrasion resistance comparisons are not practical for fabrics have a different mass because the change in abrasion resistance is not directly proportional to the change in the fabric mass.

5.9 All the guides and instruments that have been developed for abrasion resistance may show a high degree of variability in results obtained by different operators and in different laboratories; however, they represent the methods most widely used in the industry. Because there is a definite need for measuring the relative resistance to abrasion, this is one of the several standardized guides and methods that is useful to help minimize the inherent variation in results that may occur.

6. Apparatus and Materials

6.1 The Uniform Abrasion Tester⁸, shown in Figs. 1 and 2, consists of an abrading mechanism, specimen supporting mechanism, and driving mechanism. Essentially, the surface of the abrasant lies in a plane parallel to the surface supporting the specimen and presses upon the specimen. The abrasant and specimen rotate in the same direction at very nearly but not quite the same angular velocity (250 rpm) on noncoaxial axes which are parallel to within 0.0025 mm (0.0001 in.).

6.1.1 The small difference in speed is to permit each part of the specimen to come in contact with a different part of the abrasant at each rotation. Each rotation is equivalent to one cycle.

6.1.2 The abrading mechanism consists of the abrasant mounted at the lower end of a shaft, weights placed on the upper end of the shaft to produce constant pressure between abrasant and specimen throughout the test, lever and cam for raising and lowering the abrasant, shaft, and weights. A counterweight for balancing the abrasant and abrasant shaft is needed when tests are to be carried out at low pressure.

6.1.2.1 Weights, in increments of 500 g (1 lb) that are capable of providing up to a total of 5 kg (10 lb) to the specimen in pressure. Individual weight tolerances are ±1 %.

6.1.3 The specimen-supporting mechanism provides for tension mounting of thinner, more flexible materials and rigid mounting of thick, stiff materials. For the first, a plastic pressure foot 12.5, 25, 31, 38, or 50 mm (½, 1, 1¼, 1½, or 2 in.) in diameter, as prescribed, shall be mounted at the upper end of the specimen shaft to fix the area of the specimen to be abraded. A conical clamp seat, fitted to the shaft, rotates with it but is free to move vertically on the shaft. A cam is provided for raising and lowering the clamp seat. The specimen clamp shown unassembled in Fig. 3 fits on the seat (C, Fig. 3) and can be fastened to it by merely rotating it slightly to engage the two pins in the slots. The clamp and specimen assembly can be removed quickly for examining the specimen and measuring the wear and returned to the machine without unclamping the specimen. When the clamp seat is lowered by turning the cam, the combined mass of the clamp seat and specimen clamp is suspended by the specimen over the presser foot. This places the specimen under constant tension throughout the test with take-up of any stretch in the specimen. Different tensions may be applied to the specimen by changing the mass of the clamp seat, for example, by adding auxiliary weights as in 6.1.2.1.

⁸ Apparatus and accessories are commercially available.

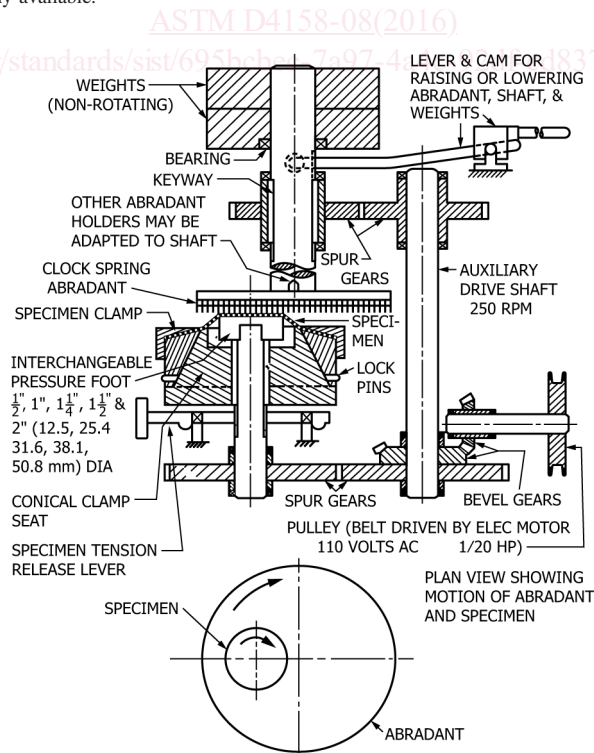
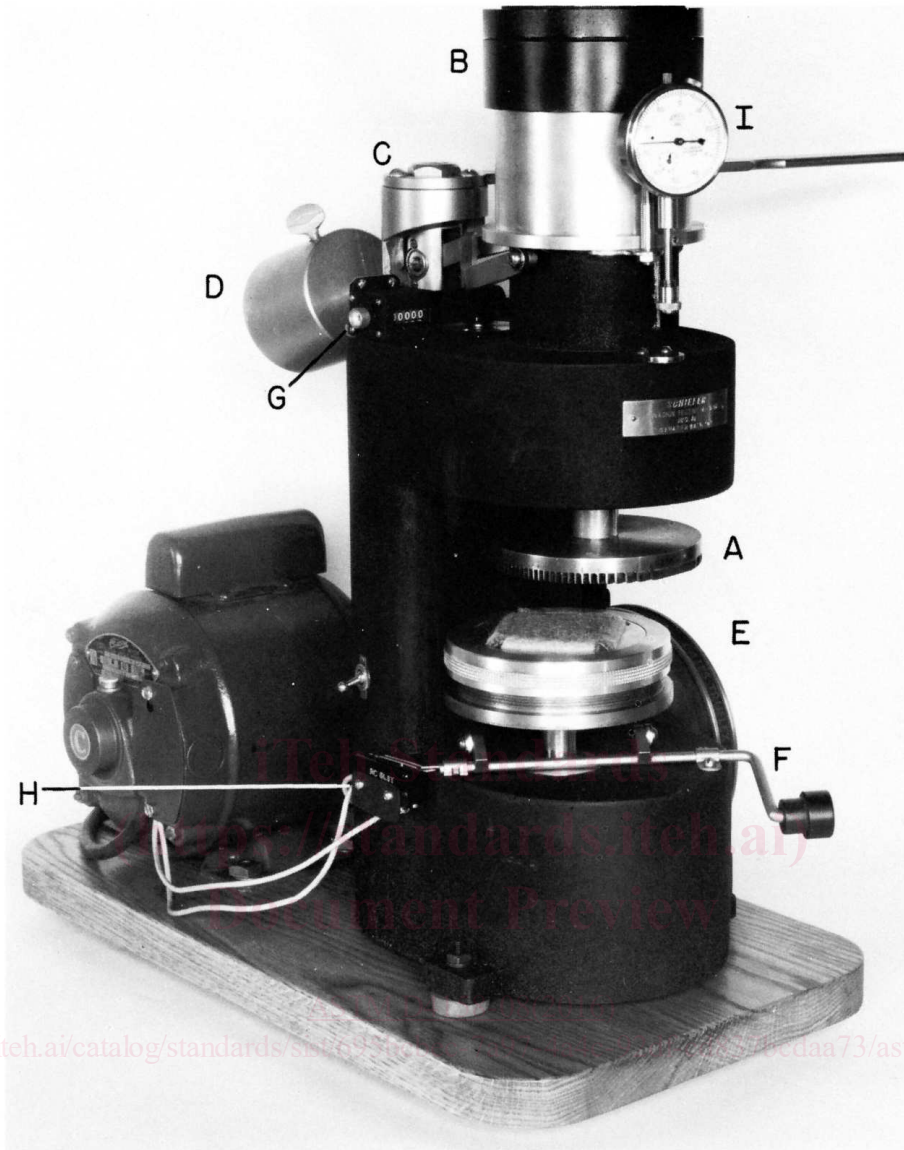

FIG. 1 Schematic Diagram of Uniform Abrasion Testing Machine



- | | |
|--|---|
| <p>A—Abradant.
 B—Weights on abradant shaft.
 C—Cam and lever system for raising the abradant shaft, abradant, and weights.
 D—Counterweight for balancing abradant and abradant shaft when tests are to be made at low pressures.</p> | <p>E—Specimen in place ready for test.
 F—Cam for raising and lowering the specimen clamp seat
 G—Counter.
 H—Microswitch.
 I—Thickness gage.</p> |
|--|---|

FIG. 2 Uniform Abrasion Testing Machine

For rigid mounting of thick, stiff fabrics such as carpeting and some felts use the specimen clamp and mounting aids shown in Fig. 4. Screw the assembly onto the specimen shaft in place of the presser foot and specimen clamp seat (E, Fig. 2).

6.1.4 The driving mechanism consists of a motor-driven auxiliary drive shaft connected to the abradant shaft and specimen shaft by spur gears.

6.1.5 The instrument shall be equipped with (1) a counter (G, Fig. 2) resettable to indicate the number of rotations in a test; (2) a sensitive microswitch (H, Fig. 2) to stop the machine automatically when a tension-suspended specimen is worn through. A thickness gage (I, Fig. 2), when specified, is available to measure changes in thickness of the specimen during the test.

6.1.5.1 Alternately the instrument may be equipped with a programmable counter that will stop the instrument upon reaching a preset number of rotations.

6.1.6 *Abradant*—Shall be sufficiently greater in diameter than the specimen supporting the surface that the latter lies entirely inside the periphery of the abradant during a test. A spring steel blade abradant (B, Fig. 3), which is essentially constant in its action

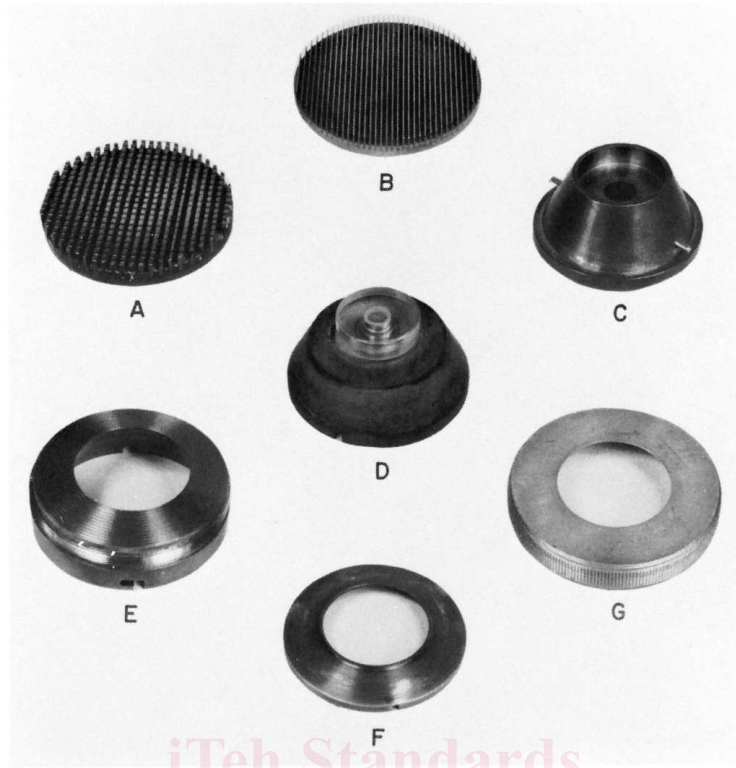

A—Cross-cut tungsten tool steel blade abradant. B—Spring steel blade abradant. C—Specimen clamp seat. D—Template, which is placed under E to bulge the specimen when mounting it. E—Base of specimen clamp, over which specimen is placed. F—Pressure ring, which is placed on specimen. G—Outer ring which is screwed down over F to hold the assembly together.

FIG. 3 Abradants; Specimen Clamp Seat; Template and Clamp for Thinner Flexible Cloths Which Are to Be Held in the Machine Under Tension

ASTM D4158-08(2016)

for a long period of use, shall be used for woven, felted, pile, and knitted fabrics and a cross-cut tungsten tool steel blade abradant (A, Fig. 3) for coated fabrics, unless otherwise specified in the material specification.

6.1.6.1 Abrasion tests are subject to variations due to changes in the abradant during specific tests. The spring steel blade abradant and the cross-cut tungsten tool steel blade abradant are considered permanent abradants that have a hardened metal surface. It is assumed that the abradant will not change appreciably in a specific series of tests, but obviously similar abradants used in different laboratories will not likely change at the same rate due to differences in usage. Permanent abradants may also change due to pick-up of treatments or other material from test fabrics and must accordingly be cleaned at frequent intervals. Consequently, depending upon its usage, the abradant must be checked periodically against a standard.

6.1.6.2 *Acetone*, or other appropriate solvent to clean the flex bar (see 8.1)

6.1.7 The standard abrasives, emery cloth, sandpaper, duck, canvas, or other cloth in a suitable holder may be needed as an abradant for some materials as agreed upon between the purchaser and the supplier. Other abradants may also be used.

7. Hazardous Materials

7.1 Solvents used in this guide may be hazardous. Refer to the manufacturer's material safety data sheets for information on use, handling, storage, and disposal of solvents used with this guide.

8. Sampling and Test Specimens

8.1 *Lot Sample*—For acceptance testing, take a lot sample as directed in the applicable material specification, or other contract. In the absence of such specification or other agreement, take a lot sample from 10 percent of the rolls or garments in the shipment rounded off to the next higher number.

8.1.1 Test sample garments as agreed upon by the purchaser and supplier.

8.1.2 *Laboratory Sampling Unit*—As a laboratory sampling unit take from rolls at least one full-width piece of fabric that is 1 m (1 yard) in length along the salvage (machine direction), after removing a first 1 m (1 yard) length. For fabric components of fabricated systems use the entire system.



A—Specimen.
B—Base of clamp.
C—Clamping plate.
D—Outer ring.

E—Pressure disk.
F—Assembly in screw press for forcing C down over specimen in order to tighten D and hold specimen firmly on the base.

FIG. 4 Specimen Clamp and Mounting Aids for Thick, Stiff Cloth Such as Carpeting and Felts, Which Are to Be Mounted Rigidly

8.1.2.1 Each garment is a laboratory sampling unit.

8.2 *Test Specimens*—From each laboratory sampling unit, cut five test specimens. If tests are to be performed on wet specimens, cut a second set of five specimens. If breaking strength of unabraded specimens is required, prepare five additional specimens as directed in Test Method **D5035** except modify the dimensions to agree with the dimensions to be used for the abraded specimens. Specimen preparation need not be carried out in the standard atmosphere for testing or proceed as per **9.1.1**. Label to maintain specimen identity.

8.2.1 For pile yarn floor coverings, rugs and thick felts, prepare specimens in the shape of a cross, with each cross-member of 50 mm (2 in.) wide and 115 mm (4.5 in.) long. See **Fig. 4**.

NOTE 2—The actual area of the specimen that is abraded in 50 mm (2 in.) square.

8.2.2 For other materials, prepare circular specimens have diameter of eighth 61, 86 or 97 mm (2.4, 3.4 or 3.8 in.).

NOTE 3—For convenience, the weight of the specimens with 61, 86 or 97 mm diameters when multiplied by the factors 10, 5 and 4 respectively provides the mass of the fabric in ounces per square yard. For the mass of the fabric in grams per square meter multiply the ounces per square yard by 33.906.

8.2.3 For fabric widths 125 mm (5 in.) or more, take no specimen closer than 25 mm (1 in.) from the selvage edge.

8.2.4 For fabric widths less than 125 mm (5 in.) use the entire width.