



Designation: ~~D3511/D3511M~~—~~15~~ ~~D3511/D3511M~~ – 16

Standard Test Method for Pilling Resistance and Other Related Surface Changes of Textile Fabrics: Brush Pilling Tester¹

This standard is issued under the fixed designation D3511/D3511M; the number immediately following the designation indicates the year of original adoption or, in the case of revision, the year of last revision. A number in parentheses indicates the year of last reappraisal. A superscript epsilon (ϵ) indicates an editorial change since the last revision or reappraisal.

This standard has been approved for use by agencies of the U.S. Department of Defense.

1. Scope

1.1 This test method covers the determination of the propensity of a fabric to form pills ~~from fuzz under test conditions intended to simulate normal wear and other related surface changes on textiles~~ using the brush pilling tester. This procedure is generally intended to be used for upholstery, automotive, luggage and heavy duty uniform fabrics because it is highly abrasive. This does ~~not however~~not, however, preclude it from being used for other types of fabrics. If unsure, comparison ~~teststesting~~ should be performed to ensure that this test method replicates pilling on the final product.

NOTE 1—For other test methods for the pilling resistance of textiles, refer to Test Methods ~~D3512D3512M~~, ~~D3514D3514M~~, and ~~D4970D4970M~~.

1.2 The values stated in either SI units or inch-pound units are to be regarded separately as standard. The values stated in each system may not be exact equivalents; therefore, each system shall be used independently of the other. Combining values from the two systems may result in non-conformance with the standard.

1.3 *This standard does not purport to address all of the safety concerns, if any, associated with its use. It is the responsibility of the user of this standard to establish appropriate safety and health practices and determine the applicability of regulatory limitations prior to use.*

2. Referenced Documents

2.1 ASTM Standards:²

D123 Terminology Relating to Textiles

~~D1776D1776M~~ Practice for Conditioning and Testing Textiles

~~D3512D3512M~~ Test Method for Pilling Resistance and Other Related Surface Changes of Textile Fabrics: Random Tumble Pilling Tester

~~D3514D3514M~~ Test Method for Pilling Resistance and Other Related Surface Changes of Textile Fabrics: Elastomeric Pad

D4850 Terminology Relating to Fabrics and Fabric Test Methods

~~D4970D4970M~~ Test Method for Pilling Resistance and Other Related Surface Changes of Textile Fabrics: Martindale Tester

2.2 ASTM Adjuncts:³

ADJD3512 Set of 5 Photographic Standards for Random Tumble Pilling Test

3. Terminology

3.1 For all terminology related to D13.59, Fabric Test Methods, General, see Terminology D4850.

3.1.1 The following terms are relevant to this standard: fuzz, pilling resistance, pills.

3.2 For all other terminology related to textiles, see Terminology D123.

¹ This test method is under the jurisdiction of ASTM Committee D13 on Textiles and is the direct responsibility of Subcommittee D13.60 on Fabric Test Methods, Specific. Current edition approved July 1, 2015 July 1, 2016. Published August 2015 July 2016. Originally approved in 1976. Last previous edition approved in 2010 2015 as ~~D3511-13-D3511-15~~, DOI: ~~10.1520/D3511-D3511M-15~~.10.1520/D3511_D3511M-16.

² For referenced ASTM standards, visit the ASTM website, www.astm.org, or contact ASTM Customer Service at service@astm.org. For Annual Book of ASTM Standards volume information, refer to the standard's Document Summary page on the ASTM website.

³ Available from ASTM International Headquarters. Order Adjunct No. ADJD3512.

4. Summary of Test Method

4.1 Pilling and other changes in surface appearance, such as fuzzing, which occur in normal wear are simulated on laboratory testing machines. Fabrics are subjected to simulated wear conditions: first brushing the specimens to free fiber ends that form fuzz on the surface of the fabric, then rubbing two of the specimens together in circular motion to roll the fiber ends into pills. The degree of fabric pilling is evaluated by comparing the tested specimens with visual standards, which may be actual fabrics or photographs of fabrics, showing a range of pilling resistance. The observed resistance to pilling is reported using an arbitrary rating scale.

5. Significance and Use

5.1 *Acceptance Testing*—This method of testing fabrics for resistance to pilling is not recommended for acceptance testing. If it is used for acceptance testing, it should be used with caution because interlaboratory data are not available. In some cases the purchaser and the supplier may have to test a commercial shipment of one or more specific materials by the best available method, even though the method has not been recommended for acceptance testing.

5.1.1 If there are differences or practical significance between reported test results for two laboratories (or more), comparative tests should be performed to determine if there is a statistical bias between them, using competent statistical assistance. As a minimum, the test samples should be used that are as homogeneous as possible, drawn from the material from which the disparate test results were obtained, and randomly assigned in equal numbers to each laboratory for testing. Other materials with established test values may be used for this purpose. The test results from the two laboratories should be compared using a statistical test for unpaired data, at a probability level chosen prior to the testing series. If a bias is found, either its cause must be found and corrected, or future test results for that material must be adjusted in consideration of the known bias.

5.2 The pilling of textile fabrics is a very complex property because it is affected by many factors which may include type of fiber or blends, fiber dimensions, yarn and fabric construction, fabric finishing treatments and refurbishing method. Testing before refurbishing may be ~~adviseable~~ advisable. The pilling resistance of a specific fabric in actual wear varies more with general conditions of use and individual wearers than in replicate fabric specimens subjected to controlled laboratory tests. This experience should be borne in mind when adopting levels of acceptability for any series of standards.

5.3 Pills vary appreciably in size and appearance and depend on the presence of lint and degree of color contrast. These factors are not evaluated when pilling is rated solely on the number of pills. The development of pills may be accompanied by other surface phenomena such as loss of cover, color change, or the development of fuzz. Since the overall acceptability of a specific fabric is dependent on both the characteristics of the pills and the other factors affecting surface appearance, it is suggested that fabrics tested in the laboratory be evaluated subjectively with regard to their acceptability and not rated solely on the number of pills developed. A series of standards, based on graduated degrees of surface change of the fabric type being tested, may be set up to provide a basis for subjective ratings. The visual standards are most advantageous when the laboratory test specimens correlate closely in appearance with worn fabrics and show a similar ratio of pills to fuzz. Counting the pills and weighing their number with respect to their size and contrast, as a combined measure of pilling resistance, is not recommended because of the excessive time required for counting, sizing, and calculation.

5.4 The degree of fabric pilling is evaluated by comparing the tested specimens with visual standards, which may be actual fabrics or photographs of fabrics, showing a range of pilling resistance. The observed resistance to pilling is reported on an arbitrary scale ranging from 5 (no pilling) to 1 (very severe pilling).

5.5 This test method is applicable to a wide variety of woven and knitted fabrics that vary in pilling propensity as a result of variations in fiber, yarn & fabric structure, and finish.

6. Apparatus and Materials

6.1 *Brush Pilling Tester*⁴, (Fig. 1), consisting of the parts described as follows:

6.1.1 *Rotating Platform*, which operates on a 19-mm [0.75-in.] radius at 6.1 rad/s [1r/s].

6.1.2 *Nylon Brushes*, mounted on plywood holders, each of which is removable and is fitted to the rotating platform. The specifications for the brushes and accessories are as follows:

6.1.2.1 *Brushes*⁵—Fuller Gript Brush Strip, No. 8B904113, 790 mm [31 in.] long; eight per tester.

6.1.2.2 *Brush Strip Height*—A height of 24 mm [.94 in.] with an overall height of 32 mm [1.25 in.], including the backing but not the 9C-7200 holders.

6.1.2.3 *Brush Bristles*—Black nylon, 0.25-mm [10-mil] diameter.

6.1.2.4 *Brush Holders*—Fuller Brush No. 9C-7200,⁵ 2-strip channel, 790 mm [31 in.] long.

6.1.2.5 *Brush Mounting*—9C-7200 holders spaced 35 mm [1.37 in.] center hole to center hole.

6.1.2.6 *Emery Paper 320*—Grit for sanding brushes.

⁴ Apparatus is commercially available.

⁵ Apparatus is commercially available.

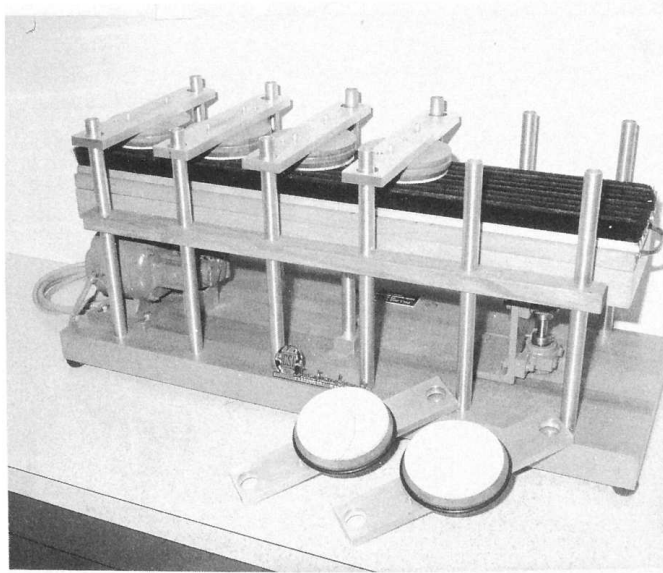

FIG. 1 Brush Pilling Tester

6.1.2.7 *Cleaning Solvent*, acetone or other appropriate solvent to clean brushes (see 7.1 and 10.1.2).

6.1.3 *Specimen Holder*, (Fig. 2), six, each weighing 660 ± 5 g, on which the fabric specimens are mounted. The face of the holders shall be covered with 3-mm [0.13 in] thick by 108-mm [4.25-in.] diameter soft cellular rubber to prevent specimen slippage during testing.

6.2 *Apparatus for Fabric Evaluation*⁴(Fig. 3) — Facilities for illumination (cool white fluorescent tube) and simultaneous viewing of test specimen and fabric or photographic rating standards. Apparatus and options for visual evaluation are listed in Table 1.

6.3 *Standard In-House Pilling Test Fabric*, having an established pilling resistance rating, for checking machine performance. No universal standard fabric is available. Each test facility must decide on an appropriate fabric.

6.4 *Rating Standards:*

6.4.1 *Fabric*—A series of tested specimens of a specific type in-house fabric, which shows degrees of pilling or other distortions, or both, for each type of fabric to be tested. Store the in-house fabric rating standards and handle them under conditions that will preserve their original form and appearance.

6.4.2 *Photographic*— A set of 5 photographs, 105 mm square [4.13 in.], numbered 1 to 5, illustrating varying degrees of pilling from “very severe pilling” to “no pilling”, such as Adjunct [D3512/ADJD3512](#).

6.4.3 *Digital Imaging or Rating System*, or both.

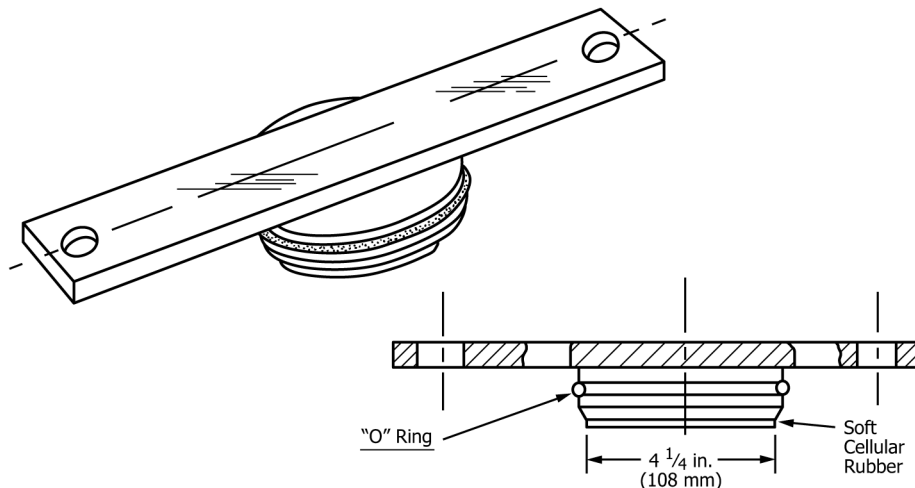

FIG. 2 Specimen Holder