



Designation: ~~D2782 – 02 (Reapproved 2014)~~ D2782 – 02 (Reapproved 2014)^{ε1}

240/84

Standard Test Method for Measurement of Extreme-Pressure Properties of Lubricating Fluids (Timken Method)¹

This standard is issued under the fixed designation D2782; the number immediately following the designation indicates the year of original adoption or, in the case of revision, the year of last revision. A number in parentheses indicates the year of last reapproval. A superscript epsilon (ϵ) indicates an editorial change since the last revision or reapproval.

^{ε1} NOTE—The IP logo and designation were removed and footnote 1 was corrected editorially in July 2016.

1. Scope

1.1 This test method covers the determination of the load-carrying capacity of lubricating fluids by means of the Timken Extreme Pressure Tester.

NOTE 1—This test method is suitable for testing fluids having a viscosity of less than about ~~5000 cSt (5000 mm²/s)~~ 5000 cSt (5000 mm²/s) at ~~40°C~~ 40 °C. For testing fluids having a higher viscosity, refer to **Note 5** in **9.1**.

1.2 The values stated in SI units are to be regarded as standard. Because the equipment used in this test method is available only in inch-pound units, SI units are omitted when referring to the equipment and the test specimens.

1.3 *This standard does not purport to address all of the safety concerns, if any, associated with its use. It is the responsibility of the user of this standard to establish appropriate safety and health practices and determine the applicability of regulatory limitations prior to use.* Specific warning statements are given in **7.1**, **7.2**, **8.1**, **8.2**, **9.4**, and **9.9**.

2. Referenced Documents

2.1 *ASTM Standards:*²

D2509 Test Method for Measurement of Load-Carrying Capacity of Lubricating Grease (Timken Method)

D4175 Terminology Relating to Petroleum Products, Liquid Fuels, and Lubricants

G40 Terminology Relating to Wear and Erosion

<https://standards.iteh.ai>

<https://standards.iteh.ai/catalog/standards/sist/4cd8e5b3-2a4c-4ded-b817-79710fe3bae1/astm-d2782-022014e1>

¹ This test method is under the jurisdiction of ASTM Committee **D02** on Petroleum Products, Liquid Fuels, and Lubricants and is the direct responsibility of Subcommittee **D02.L0.11** on ~~Tribological~~ **Tribological** Properties of Industrial Fluids and Lubricates.

Current edition approved May 1, 2014. Published July 2014. Originally approved in 1969. Last previous edition approved in 2008 as D2782 – 02 (2008). DOI: 10.1520/D2782-02R14E01.

This test method was adopted as a joint ASTM-IP Standard.

This test method was prepared under the joint sponsorship of the American Society of Lubrication Engineers. Accepted by STLE January 1969. DOI: 10.1520/D2782-02R14.

² For referenced ASTM standards, visit the ASTM website, www.astm.org, or contact ASTM Customer Service at service@astm.org. For *Annual Book of ASTM Standards* volume information, refer to the standard's Document Summary page on the ASTM website.

2.2 ASTM Adjuncts:

Photograph of Test Blocks Showing Scars³

3. Terminology

3.1 Definitions:

3.1.1 *extreme pressure (EP) additive, n, in a lubricant*—a substance that minimizes damage to metal surfaces in contact under high-stress rubbing conditions. **D4175**

3.1.2 *lubricant, n*—any substance interposed between two surfaces for the purpose of reducing friction or wear between them. **G40**

3.1.3 *scoring, n, in tribology*—a severe form of wear characterized by the formation of extensive grooves and scratches in the direction of sliding. **G40**

3.1.4 *wear, n*—damage to a solid surface generally involving progressive loss of material, due to relative motion between that surface and a contacting substance or substances. **G40**

3.2 Definitions of Terms Specific to This Standard:

3.2.1 *load-carrying capacity of a lubricant*— as determined by this test method, the maximum load or pressure that can be sustained by the lubricant (when used in the given system under specific conditions) without failure of the sliding contact surfaces as evidenced by scoring or seizure or asperity welding.

3.2.2 *OK value, n*—as determined by this test method, the maximum mass (weight) added to the load lever weight pan, at which no scoring or seizure occurs.

3.2.3 *score value, n*—as determined by this test method, the minimum mass (weight) added to the load lever weight pan, at which scoring or seizure occurs.

³ Available from ASTM International Headquarters. Order Adjunct No. ADJD2509. Original adjunct produced in 1972.

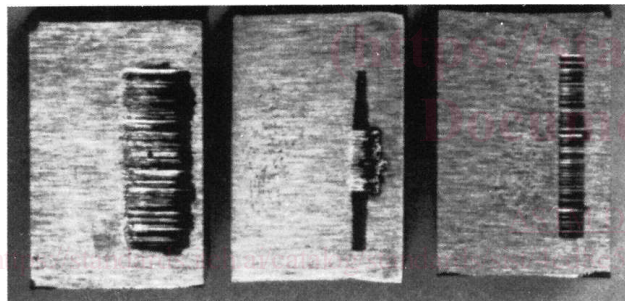

FIG. 2 Scoring

3.2.3.1 Discussion—

When the lubricant film is substantially maintained, a smooth scar is obtained on the test block, but when there is a breakdown of the lubricant film, scoring or surface failure of the test block takes place, as shown in Figs. 1 and 2. In its simplest and most recognized form, scoring is characterized by the furrowed appearance of a wide scar on the test block and by excessive pick-up of metal on the surface of the test cup. The form of surface failure more usually encountered, however, consists of a comparatively smooth scar, which shows local damage that usually extends beyond the width of the scar. Scratches or striations that occur in an otherwise smooth scar and that do not extend beyond the width of the scar are not considered as evidence of scoring.

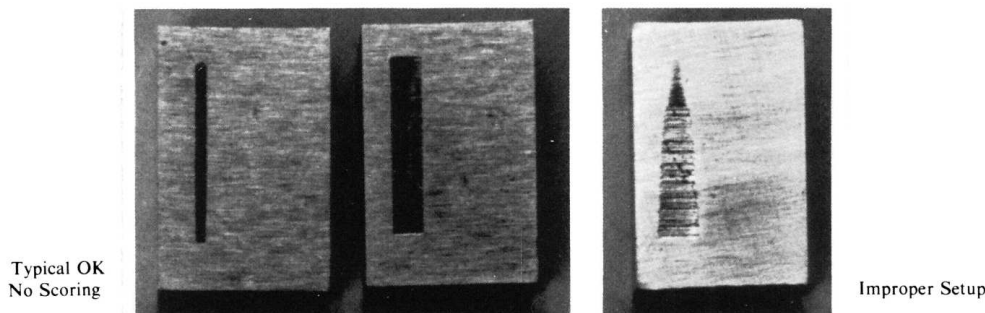

FIG. 1 Test Blocks Showing Various Types of Scar

3.2.4 *seizure or asperity welding*—localized fusion of metal between the rubbing surfaces of the test pieces. Seizure is usually indicated by streaks appearing on the surface of the test cup, an increase in friction and wear, or unusual noise and vibration. Throughout this test method the term *seizure* is understood to mean *seizure or asperity welding*.

4. Summary of Test Method

4.1 The tester is operated with a steel test cup rotating against a steel test block. The rotating speed is ~~123.71 ± 0.77 m/min~~ $123.71 \text{ m/min} \pm 0.77 \text{ m/min}$ (~~405.88 ± 2.54 (405.88 ft/min ± 2.54 ft-ft/min)/min~~), which is equivalent to a spindle speed of ~~800 ± 5800 r/min ± 5 r-rpm./min.~~ Fluid samples are preheated to ~~37.8 ± 2.8°C (100 ± 5°F)~~ $37.8 \text{ °C} \pm 2.8 \text{ °C}$ ($100 \text{ °F} \pm 5 \text{ °F}$) before starting the test.

4.2 Two determinations are made: the minimum load (score value) that will rupture the lubricant film being tested between the rotating cup and the stationary block and cause scoring or seizure; and the maximum load (OK value) at which the rotating cup will not rupture the lubricant film and cause scoring or seizure between the rotating cup and the stationary block.

5. Significance and Use

5.1 This test method is used widely for the determination of extreme pressure properties for specification purposes. Users are cautioned to carefully consider the precision and bias statements herein when establishing specification limits.

6. Apparatus

6.1 *Timken Extreme Pressure Tester*,⁴ described in detail in [Annex A1](#) and illustrated in [Fig. 3](#).

6.2 *Sample Feed Device*,⁴ for supplying the test specimens with fluid is described in [Annex A1](#).

6.3 *Loading Mechanism*,⁴ for applying and removing the load weights without shock at the uniform rate of ~~0.91 to 1.36 kg/0.91 kg/s to 1.36 kg/s (2(2 lb-to-3/s to 3 lb-lb/s)-/s).~~ A detailed description is given in [Annex A1](#).

6.4 *Microscope*,⁴ low-power (50× to 60×) having sufficient clearance under objective to accommodate the test block. It should be fitted with a filar micrometer so that the scar width may be measured with an accuracy of ~~±0.05 mm (±0.002 in.); ±0.05 mm (±0.002 in.).~~

6.5 *Timer*, graduated in minutes and seconds.

7. Reagents and Materials

7.1 *Acetone*, reagent grade. (~~Warning—WarningExtremely—Extremely flammable. Harmful when inhaled. See A3.1.)~~)

7.2 *Stoddard Solvent or White Spirit*, reagent grade. (~~Warning—WarningFlammable.—Flammable. See A3.2.)~~)

7.3 *Test Cup*,^{4,5} of carburized steel, having a Rockwell Hardness “C” Scale Number of 58 to 62, or a Vickers Hardness Number of 653 to 756. The cups have a width of ~~0.514 ± 0.002 in., 0.514 in. ± 0.002 in.,~~ a perimeter of ~~6.083 ± 0.009 in., 6.083 in. ± 0.009 in.,~~ a diameter of ~~1.938 + 0.001, - 0.005 in. 1.938 in. + 0.001 in., - 0.005 in.~~ and a maximum radial run-out of 0.0005 in. The axial surface roughness should lie between ~~0.51 ± 0.51 μm~~ and 0.76 μm (~~20(20 μin. and 30 μin.) C.L.A.~~)

7.4 *Test Blocks*,^{4,6} with test surfaces ~~0.485 ± 0.002 in. 0.485 in. ± 0.002 in.~~ wide and ~~0.750 ± 0.016 in. 0.750 in. ± 0.016 in.~~ long, of carburized steel, having a Rockwell Hardness “C” Scale Number of 58 to 62, or a Vickers Hardness Number of 653 to 756. Each block is supplied with four ground faces and the surface roughness should lie between ~~0.51 ± 0.51 μm~~ and 0.76 μm (~~20(20 μin. and 30 μin.) C.L.A.~~)

8. Preparation of Apparatus

8.1 Clean the apparatus with (1) Stoddard solvent or White Spirit, and (2) acetone and blow dry. (~~Warning—WarningExtremely—Extremely flammable. Harmful when inhaled. See A3.1.) (Warning—WarningFlammable.—Flammable. See A3.2.)~~ Flush with approximately ~~1 L (1 qt) 1 L (1 qt)~~ of the fluid to be tested. Discard the flushing fluid. (~~Warning—WarningSince—Since acetone is highly flammable, use the minimum quantity.)~~)

8.2 Select a new test cup and block, wash with Stoddard solvent or White Spirit (~~Warning—WarningFlammable.—Flammable. See A3.2.)~~ and dry with a clean soft cloth or paper. Immediately before use rinse the test cup and block with acetone and blow them dry. Do not use solvents such as carbon tetrachloride or others that may inherently possess load-carrying properties which may effect the results.

NOTE 2—This cleaning may be done in an ultrasonic cleaner.

⁴ The sole source of supply of the apparatus known to the committee at this time is Falex Corp., 1020 Airpark Dr., Sugar Grove, IL 60554. If you are aware of alternative suppliers, please provide this information to ASTM International Headquarters. Your comments will receive careful consideration at a meeting of the responsible technical committee,¹ which you may attend.

⁵ Available from Falex Corp., under Part No. F-25061.

⁶ Available from Falex Corp., under Part No. F-25001.

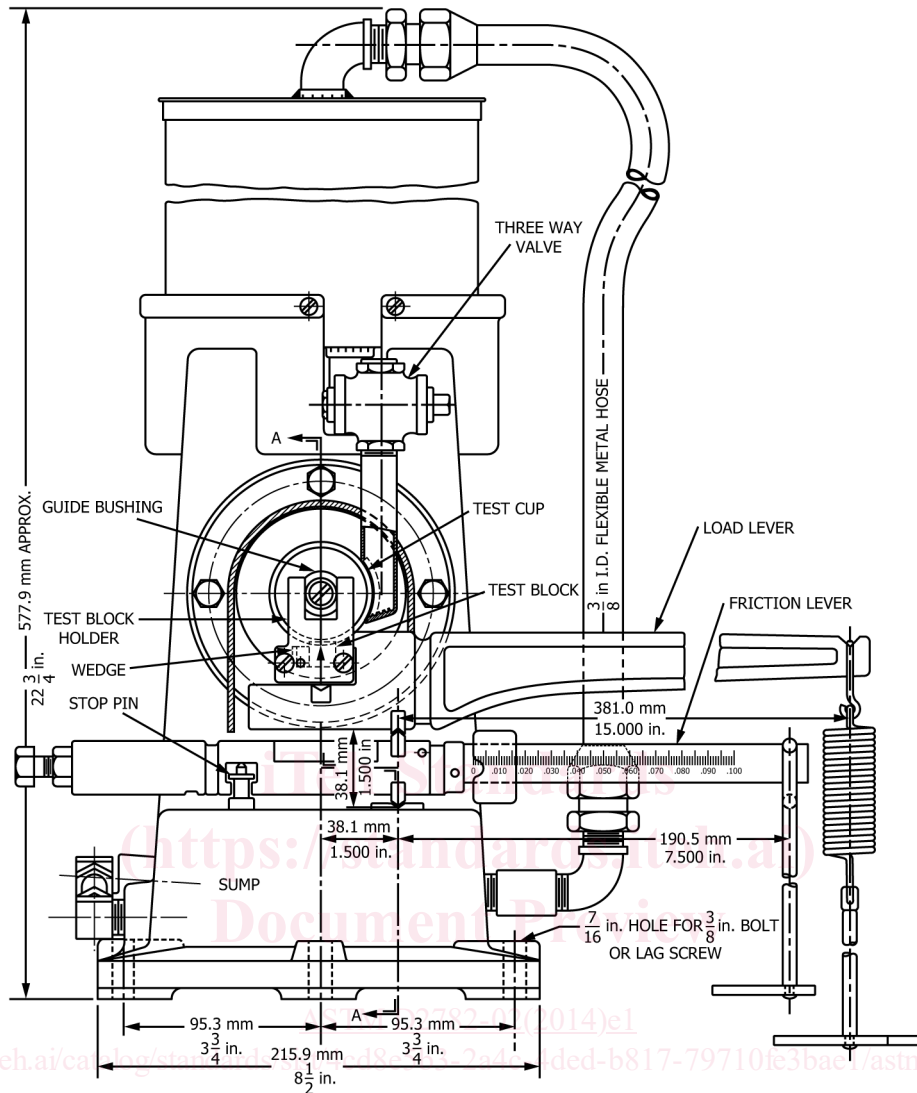

FIG. 3 Timken Tester

8.3 Assemble the tester carefully (Fig. 4), placing the test cup on the spindle and making certain that it is well seated, drawing it up firmly but avoiding possible distortion from excessive tightening (Note 3). Place the test block in the test block holder and adjust the levers so that all the knife edges are in proper alignment. Exercise special care in placing the stirrup of the spring-weight platform assembly (selection of which will depend on the loading device) in the groove of the load-lever arm to avoid premature shock to the test block when the load is applied. To ensure that the test block, test block holder, and lever arms are properly aligned and seated, coat the test block and test cup with the lubricant to be tested, and rotate the machine slowly for a few revolutions either by hand or by suitable control mechanism. When the parts are in alignment, the fluid will be wiped off the cup over its entire width.

NOTE 3—At this point it is recommended that a dial indicator used to check the radial run-out of the cup *in situ* not exceed 0.025 mm (0.001 in.) 0.025 mm (0.001 in.) total indicator movement.

9. Procedure

9.1 Fill the reservoir of the tester to within 76 mm (3 in.) of the top (approximately 3 L or 3 qt) with the fluid to be tested. Preheat the fluid to $37.837.8\text{ }^\circ\text{C} \pm 2.8\text{ }^\circ\text{C}$ ($100\text{ }^\circ\text{F} \pm 5\text{ }^\circ\text{F}$).

NOTE 4—The fluid may be heated by the use of an immersion heater located in the tester reservoir or by heating the fluid prior to filling the reservoir. If an immersion heater is used, localized overheating must be avoided. This may be done by stirring or by circulating prior to the assembly of the lever arm.

NOTE 5—Fluids having a viscosity above about 5000 cSt ($5000\text{ mm}^2/\text{s}$) at $40\text{ }^\circ\text{C}$ often cannot be tested at the prescribed fluid temperature of $37.837.8\text{ }^\circ\text{C} \pm 2.8\text{ }^\circ\text{C}$ ($100\text{ }^\circ\text{F} \pm 5\text{ }^\circ\text{F}$) because of inability of the pump to recirculate the fluid at this temperature. However, results from limited cooperative tests, covered in Tables A1.1 and A1.2, indicate that the starting fluid temperature could be increased to $65.6\text{ }^\circ\text{C}$ ($150\text{ }^\circ\text{F}$) to obtain adequate flow without affecting OK or score values. Testing of such high-viscosity fluids at room temperature in the Test Method D2509 grease feeder also appears valid but may be difficult because of fluid leakage.

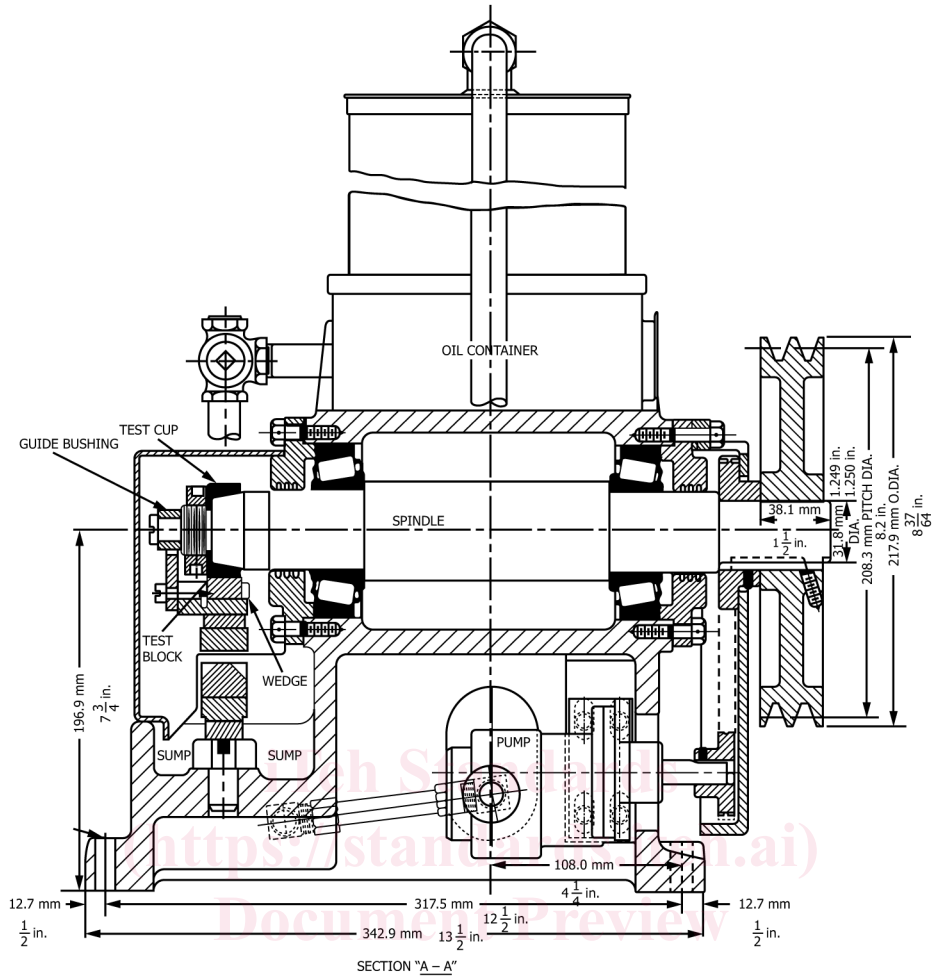

FIG. 3 (continued)

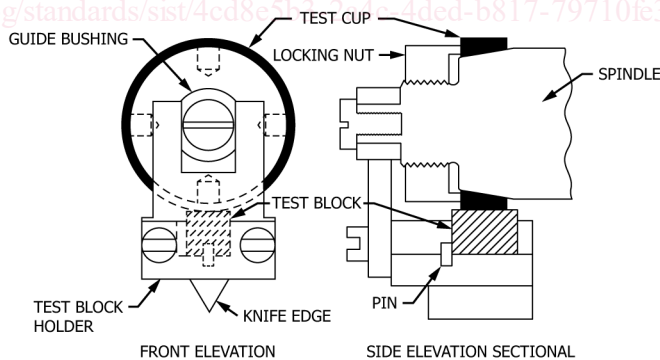

FIG. 4 Assembly of Tester Showing Test Pieces

9.2 Set the discharge valve at full open. Allow the lubricant to flood the test cup and block. When the sump is about half filled with the fluid, start the motor and run for 30 s–30 s to break-in. If the equipment used is equipped with acceleration control, start the motor and increase the spindle speed gradually to achieve 800 r/min ± 5 r/min after 15 s. Run for a further 15 s–15 s to complete the break-in.

9.3 After a break-in period of 30 s–30 s, start the timer and apply at 8.98.9 N/s to 13.313.3 N N/s (2 lbf (2/s to 33 lbf lbf/s), /s), a load that is less than the expected score load. In the absence of a better estimate, a starting load of 30 lbf–30 lbf is recommended. The load-lever arm, spring-weight platform assembly is not considered a part of the applied load. In the event a lower starting load is used, it must be a multiple of 6. Then allow the machine to run at 800 ± 5 r/min 800 r/min ± 5 r/min for 10 min ± 15 s after load application is initiated, unless a score is detected before that period.

9.4 If, after the load has been applied, scoring is evident by vibration or noise, stop the tester at once, turn off the flow of lubricant, and remove the load. Since the excessive heat developed with deep scoring may alter the surface characteristics of the entire block, discard the test block. (~~Warning—Warning~~~~The—The~~ machine and test pieces may be hot at this point and care should be exercised in their handling.)

9.5 If no scoring is detected, allow the tester to run for ~~10 min ± 15 s~~ 10 min ± 15 s from the start of the application of the load. At the end of the ~~10 min ± 15 s~~ 10 min ± 15 s period, reverse the loading device and remove the load from the lever arm. Turn off the motor, allow the spindle to come to rest, then turn off the flow of fluid. Remove the load lever and inspect the condition of the test block surface at 1× magnification. Microscopical observations shall not be used to define when scoring has occurred. The lubricant has failed at the imposed load if the wear scar indicates any scoring or welding.

NOTE 6—A microscope may be used to examine the wear scar for further information as required in 9.9.

9.6 If no score is observed, turn the test block to expose a new surface of contact and, with a new test cup, repeat the test, as in 9.5, at ~~10-lbf~~ 10 lbf increments until a load that produces a score is reached. At this point decrease the load by ~~5-lbf~~ 5 lbf for the final determination.

NOTE 7—Before each test in 9.6 – 9.8 cool the fluid in the reservoir to ~~37.8/37.8 °C ± 2.8°C (100.2 °C (100 °F ± 5°F); 5 °F)~~, cool the shaft to less than ~~65.6°C (150°F); 65.6 °C (150 °F)~~, install a new test cup, and turn the test block to expose a new surface of contact. When seizure has occurred, discard the entire test block since excessive heat, developed when scarring occurs, may alter the surface characteristics of the entire block.

9.7 If a score is produced at the ~~30-lbf~~ 30 lbf load, reduce the load by ~~6-lbf~~ 6 lbf decrements until no scoring is realized. At this point, increase the load by ~~3-lbf~~ 3 lbf for the final determination.

9.8 When the wear scar evidence at any load stage makes the definition of the onset of scoring questionable, repeat the test at the same load. If the second test produces a score, record a score rating for this load. Similarly, if the second test produces no scoring, record a no score rating. If the second test again yields a questionable result, simply withhold judgment of the rating at this load stage and test the fluid at the immediately next higher load stage (see Annex A2). Then assign a rating to the load stage in question that is identical to the rating obtained at the immediately next higher load stage employed.

9.9 After the OK value has been determined, remove the test block and wash with Stoddard solvent or White Spirit, rinse with acetone (~~Warning—Warning~~~~Extremely—Extremely~~ flammable. Harmful when inhaled. See A3.1.) (~~Warning—Warning~~~~Flammable.—Flammable.~~ See A3.2.), and blow dry. By means of a filar micrometer microscope, measure the width of the scars on those blocks which successfully carried this load. Make all measurements to ~~0.05 mm (0.002 in.)~~ 0.05 mm (0.002 in.).

10. Calculation

10.1 When desired, the contact (unit) pressure that exists between the cup and block at the conclusion of the test can be calculated. Calculate the contact pressure, *C*, as follows:

$$C, \text{ psi} = [L(X+G)]/YZ \text{ or } [20(X+G)]/Z \quad (1)$$

$$C, \text{ MPa} = 9.81[L(X'+0.454G)]/Y'Z' \quad (2)$$

where:

- L* = mechanical advantage of load-lever arm, 10,
- G* = load-lever constant (value is stamped on lever arm of each tester),
- X* = mass (weight) placed on the weight pan, lb,
- X'* = mass (weight) placed on the weight pan, kg,
- Y* = length of test scar (½ in.),
- Y'* = length of test scar (12.7 mm),
- Y'* = length of test scar (12.7 mm),
- Z* = average width of test scar, in., and
- Z'* = average width of test scar, mm.

10.2 For convenience, contact (unit) pressures in pounds per square inch are listed in Table X3.1.

11. Report

11.1 Report the OK and score values in terms of the mass (weights) placed on the weight pan hanging from the end of the load-lever arm; do not include the mass (weight) of the pan assembly. Report the values in multiples of ~~5-lb~~ above 30-lb above 30 lb and in multiples of ~~3-lb~~ below 30-lb below 30 lb.

12. Precision and Bias⁷

12.1 The precision and this test method as determined by the statistical examination of interlaboratory test results is as follows:

⁷ Supporting data have been filed at ASTM International Headquarters and may be obtained by requesting Research Report RR:D02-1223.