



Designation: F1004 – 16b

Standard Consumer Safety Specification for Expansion Gates and Expandable Enclosures¹

This standard is issued under the fixed designation F1004; the number immediately following the designation indicates the year of original adoption or, in the case of revision, the year of last revision. A number in parentheses indicates the year of last reapproval. A superscript epsilon (ϵ) indicates an editorial change since the last revision or reapproval.

INTRODUCTION

This consumer safety specification addresses incidents of head and neck entrapment in children's expansion gates and expandable enclosures. It also addresses the ability of a pressure gate to resist a push-out force.

The U.S. Consumer Product Safety Commission (CPSC) identified incidents that generally involved a child's head or neck, or both, becoming entrapped in diamond shaped openings and strangulation of children in V-shapes at the top of accordion style expansion gates or expandable enclosures. Additional incidents and injuries were identified that involved children attempting to climb up and over expansion gates and expandable enclosures, and pushing or pulling pressure gates out of doorways.

This consumer safety specification is written within the current state-of-the-art of gate and enclosure technology. It is intended that this consumer safety specification will be updated whenever substantive information becomes available, which necessitates additional requirements or justifies the revision of existing requirements.

This specification does not address incidents in which gates or enclosures are blatantly misused although warnings and safety instructions are required to be displayed prominently on and with each gate or enclosure.

1. Scope

1.1 This consumer safety specification covers minimum safety performance requirements, test methods, and requirements for labeling and instructional material to minimize hazards to young children resulting from the normal use and reasonably foreseeable misuse and abuse of expansion gates and expandable enclosures.

1.2 Products known as expansion gates and expandable enclosures, or by any other name, which are in the scope of this consumer safety specification are intended for young children aged six months through 24 months, and are defined in Section 3.

1.3 Expansion gates and expandable enclosures defined in Section 3 are for domestic use and are not to be confused with

¹ This consumer safety specification is under the jurisdiction of ASTM Committee F15 on Consumer Products and is the direct responsibility of Subcommittee F15.16 on Highchairs, Hook-On Chairs and Expandable Gates.

Current edition approved July 15, 2016. Published August 2016. Originally approved in 1986. Last previous edition approved in 2016 as F1004 – 16a. DOI: 10.1520/F1004-16B.

other types of gates or enclosures that may be specifically designed for commercial, institutional, agricultural, pet use, or any other such use.

1.4 No expansion gate or expandable enclosure as defined in Section 3, that is, produced after the approval date of this consumer safety specification either by label or other means, shall indicate compliance with this specification unless it conforms to all the requirements contained herein.

1.5 For expediency, expansion gates and expandable enclosures as defined in Section 3 will heretofore be referred to in this consumer safety specification as "gates" and "enclosures" unless referred to definitively.

1.6 The values stated in inch-pound units are to be regarded as standard. The values given in parentheses are mathematical conversions to SI units that are provided for information only and are not considered standard.

1.7 The following pertains only to the test methods portion, Section 7, of this specification. *This standard does not purport to address all of the safety concerns, if any, associated with its use. It is the responsibility of the user of this standard to*

establish appropriate safety and health practices and determine the applicability of regulatory limitations prior to use.

2. Referenced Documents

2.1 ASTM Standards:²

D3359 Test Methods for Measuring Adhesion by Tape Test

F406 Consumer Safety Specification for Non-Full-Size Baby Cribs/Play Yards

F963 Consumer Safety Specification for Toy Safety

2.2 British Standard:³

BS 4125 Specification for Safety Requirements for Child Safety Barriers for Domestic Use

2.3 Federal Regulations:⁴

16 CFR 1303 Ban of Lead-Containing Paint and Certain Consumer Products Bearing Lead Containing Paint

16 CFR 1500 Hazardous Substances Act Regulations, Including Parts:

16 CFR 1500.48 Technical Requirements for Determining a Sharp Point in Toys and Other Articles Intended for Use by Children Under Eight Years of Age

16 CFR 1500.49 Technical Requirements for Determining a Sharp Metal or Glass Edge in Toys and Other Articles Intended for Use by Children Under Eight-Years of Age

16 CFR 1501 Method for Identifying Toys and Other Articles Intended for Use by Children Under Three Years of Age Which Present Choking, Aspiration, or Ingestion Hazards Because of Small Parts

3. Terminology

3.1 Definitions of Terms Specific to This Standard:

3.1.1 *automatic closing system, n*—a feature (or mechanism) the manufacturer claims, markets, or intends to close an egress panel automatically without the intervention of the user.

3.1.2 *completely-bounded opening, n*—any opening in the main structure of a product that is enclosed totally by boundaries on all sides.

3.1.3 *conspicuous, adj*—label which is visible, when the gate/expandable enclosure is in a manufacturer's recommended use position, to a person standing near the gate/expandable enclosure at any one position around the gate/expandable enclosure, but not necessarily visible from all positions.

3.1.4 *double-action release mechanism, n*—a release mechanism requiring either two consecutive actions, the first of which must be maintained while the second is carried out, or two separate and independent single action release mechanisms that must be activated simultaneously to unlock the gate/enclosure.

² For referenced ASTM standards, visit the ASTM website, www.astm.org, or contact ASTM Customer Service at service@astm.org. For *Annual Book of ASTM Standards* volume information, refer to the standard's Document Summary page on the ASTM website.

³ Available from British Standards Institute (BSI), 389 Chiswick High Rd., London W4 4AL, U.K., <http://www.bsi-global.com>.

⁴ *Code of Federal Regulations* is available from the Superintendent of Documents, Government Printing Office, Washington, DC 21402.

3.1.5 *egress panel, n*—panel(s) within a gate or enclosure designed to swing, retract, or fold open to allow passage.

3.1.5.1 *Discussion*—Pressure mounted gates that require the pressure to be released in order to allow passage, are not considered to contain an egress panel.

3.1.6 *expandable enclosures, n*—self-supporting barrier intended to completely surround an area or play-space within which a young child (see 1.2) may be confined.

3.1.6.1 *Discussion*—Enclosures may be marketed for indoor or outdoor use, or both. Expandable enclosures do not include an attached floor.

3.1.7 *expansion gate, n*—barrier intended to be erected in an opening, such as a doorway, to prevent the passage of young children (see 1.2), but which can be removed by older persons who are able to operate the locking mechanism.

3.1.7.1 *Discussion*—Such gates are available in a number of different styles of construction and are manufactured from a variety of different materials.

3.1.8 *extension panel(s), n*—any panel recommended by the manufacturer for extending the length or height of the product including panels sold with the gate/enclosure and those sold separately.

3.1.9 *hold open mechanism, n*—a feature sometimes included with automatic closing gates where the gate will stay in a fully open position and not automatically close the egress panel.

3.1.10 *manufacturer's recommended use position(s)*—any position that is presented by the manufacturer in any descriptive or instructional literature as a normal, allowable, or acceptable configuration for the use of the product.

3.1.10.1 *Discussion*—This specifically excludes positions which the manufacturer shows in its literature to be unacceptable, unsafe, or not recommended.

3.1.11 *nonpaper label, n*—any label material, such as plastic or metal, which either will not tear without the aid of tools or tears leaving a sharply-defined edge.

3.1.12 *paper label, n*—any label material, which tears without the aid of tools and leaves a fibrous edge.

3.1.13 *partially-bounded opening, n*—any opening in the main structure of a product that is not enclosed totally by boundaries on all sides.

3.1.13.1 *Discussion*—For example, a V-shape in the top of an accordion slat-style product or a rectangular notch resulting from a gap between a wall surface and the main structure of a baby gate would be considered a partially-bounded opening.

3.1.14 *pressure mounted gate, n*—any gate which relies on pressure as the mechanism by which the gate stays in its manufacturer's recommended use position.

3.1.15 *static load, n*—vertically downward force applied by a calibrated force gage or by dead weights.

4. Calibration and Standardization

4.1 All testing shall be conducted on a concrete floor which may be covered with 1/8-in. (3-mm) thick vinyl floor cover, unless the test instructs differently.

4.2 The gate/expandable enclosure shall be completely assembled, unless otherwise noted, in accordance with the manufacturer's instructions.

4.3 No testing shall be conducted within 48 h of manufacturing.

4.4 The product to be tested shall be preconditioned in a room with an ambient temperature of $73 \pm 9^\circ\text{F}$ ($23 \pm 5^\circ\text{C}$) for at least 1 h prior to testing. Testing then shall be conducted within this temperature range.

4.5 All testing required by this specification shall be conducted on the same unit. The gate/expandable enclosure with and without any and all extension panels installed in any of the manufacturer's recommended use positions must comply with the standard.

5. General Requirements

5.1 *Wood Parts*—Prior to testing, any exposed wood parts shall be smooth and free from splinters. Slats are not permitted to contain any lateral/transverse joints, such as finger-joints, or any other means of joining pieces of lumber end-to-end.

5.2 Screws shall not be used in the assembly of any components or locking or attaching device (or devices) that are intended to be removed by the consumer during daily operations.

5.3 There shall be no hazardous sharp edges or points as defined by 16 CFR 1500.48 and 16 CFR 1500.49 before or after testing to this consumer safety specification.

5.4 There shall be no small parts as defined by 16 CFR 1501 before testing or liberated as a result of testing to this specification.

5.5 *Openings*—Holes or slots that extend entirely through a wall section of any rigid material less than 0.375 in. (9.53 mm) thick and admit a 0.210-in. (5.33-mm) diameter rod shall also admit a 0.375-in. (9.53-mm) diameter rod. Holes or slots that are between 0.210 in. (5.33 mm) and 0.375 in. (9.53 mm) and have a wall thickness less than 0.375 in. (9.53 mm) but are limited in depth to 0.375 in. (9.53 mm) maximum by another rigid surface shall be permissible (see Fig. 1). The product shall be evaluated in all manufacturer's recommended positions.

5.5.1 Openings through multiple wall sections and openings created by multiple wall sections must meet the size requirements in 5.5 if the total thickness of the combined wall sections and any air gap between the wall sections is less than 0.375 in. (9.53 mm).

5.6 *Exposed Coil Springs*—Any exposed coil spring, which is accessible to the occupant having or capable of generating a space between coils of 0.210 in. (5.33 mm) or greater during static load testing in accordance with 7.8 shall be covered or otherwise designed to prevent injury from entrapment.

5.7 *Scissoring, Shearing, and Pinching*—The gate/expandable enclosure when in the manufacturer's recommended use position(s) shall be designed and constructed to prevent injury to the child from any scissoring, shearing, or pinching when members or components rotate about a common axis or fastening point, slide, pivot, fold, or otherwise move

relative to one another. Scissoring, shearing, or pinching that may cause injury shall not be permissible when the edges of any rigid parts admit a probe greater than 0.210 in. (5.33 mm) and less than 0.375 in. (9.53 mm) diameter at any accessible point through the range of motion of such parts.

5.8 Labeling:

5.8.1 Warning labels (whether paper or nonpaper) shall be permanent when tested in accordance with 7.12.1 – 7.12.3.

5.8.2 Warning statements applied directly onto the surface of the product by hot stamping, heat transfer, printing, wood burning, etc., shall be permanent when tested in accordance with 7.12.4.

5.8.3 Nonpaper labels shall not liberate small parts when tested in accordance with 7.12.5.

5.9 The paint and surface coating on the product shall comply with 16 CFR 1303.

5.10 *Protective Components*—If a child can grasp protective components, such as caps, sleeves, or plugs used for protection from sharp edges, points, or entrapment of fingers or toes, between the thumb and forefinger, or teeth, or if there is at least a 0.040 in. (1.00 mm) gap between the component and its adjacent parent component, such components shall not be removed when tested in accordance with 7.7.

6. Performance Requirements

6.1 The following performance requirements apply to gates and enclosures when they are erected or installed in any of the manufacturer's recommended use positions.

6.1.1 *Completely-Bounded Openings*—Openings within the gate or enclosure, and completely bounded openings between the gate and the test fixture, shall not permit the complete passage of the Small Torso Probe (see Fig. 2) when tested in accordance with 7.10.

6.1.2 *Height of Sides*—The vertical distance from the floor to the lowest point of the uppermost surface shall not be less than 22 in. (560 mm) when measured from the floor.

6.1.3 *Vertical Strength*—Uppermost top rails, edges, or framing components of the gates or enclosures shall be tested in accordance with 7.8 and shall not fracture, disengage, fold, or have a deflection that reduces the lowest point of the uppermost surface of a gate or enclosure to a dimension of less than 22 in. (560 mm) when measured vertically from the floor at any time during or after completion of the test (see 6.1.2). The unit shall remain in its manufacturer's recommended use position and the lock/latch shall remain engaged during the test and engaged and operative upon completion of the tests described in 7.8.

6.1.4 *Bottom Spacing*—For enclosures, the space between the floor and the bottom of the enclosure shall not permit the complete passage of the Small Torso Probe (see Fig. 2) when tested in accordance with 7.10. For gates, the space between the test fixture and the bottom of the gate shall not permit the passage of the Small Torso Probe (see Fig. 2) when tested in accordance with 7.10.

6.1.5 *Configuration of Uppermost Edge*—A partially bounded opening at any point in the uppermost edge of a product that is greater than 1.5 in. (38 mm) in width and more

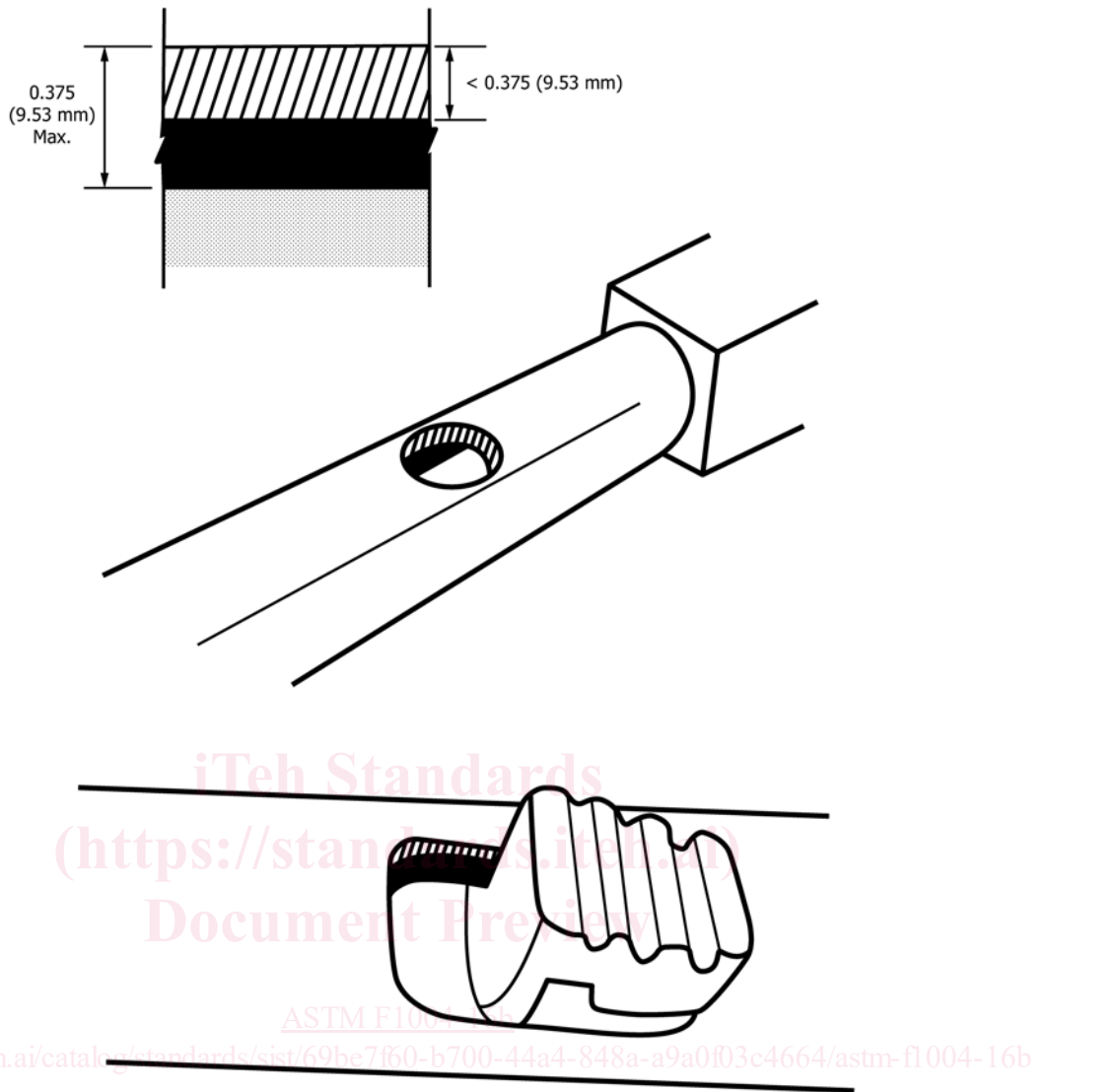

FIG. 1 Openings

than 0.64 in. (16.2 mm) in depth shall be subjected to the test procedure in 7.11 (see Fig. 3). During the test, no portions of the boundaries of the opening shall simultaneously contact more than one of surfaces “B,” “C,” or corner “BC” or “CC” in any combination if they are not opposing sides of the center line of Test Template B (see Fig. 4).

6.2 Latching/Locking and Hinge Mechanisms:

6.2.1 Pressure Mounted Gates—All pressure mounted gates shall have a latching or locking device or other provision in the design that will prevent the unit from unintentionally folding or contracting when properly placed in the manufacturer’s recommended use position.

6.2.2 Units with Egress Panels—All gates or enclosures designed with egress panels shall have a latching or locking device to keep the panel in the closed position and prevent unintentional opening. The locking or latching device shall remain engaged during and upon completion of the testing, and the locking or latching device shall remain operative upon completion of the testing in accordance with 7.3.

6.2.2.1 Automatic Closing Systems—Any unit with an automatic closing mechanism shall continue to close and automatically lock or latch, without the intervention of the user, when tested in accordance with 7.4.

6.3 Push-Out Test:

6.3.1 All gates shall be tested in accordance with 7.9. At each test location, the average push-out force shall be a minimum of 10 lbf (45 N).

6.3.2 Gates that are marketed as being usable at the top of stairs shall be tested in accordance with 7.9. At each test location, the average push-out force shall exceed 30 lbf (133 N). In addition, each individual force shall exceed 20 lbf (89 N). Gates that do not meet the test requirements in this section shall bear the warning in 8.5.5 that they shall not be used at the top of stairs.

6.4 Locking Device—Every device provided to prevent the unlocking or unlatching of a product from the manufacturer’s recommended use position(s) shall meet either 6.4.1 or 6.4.2.

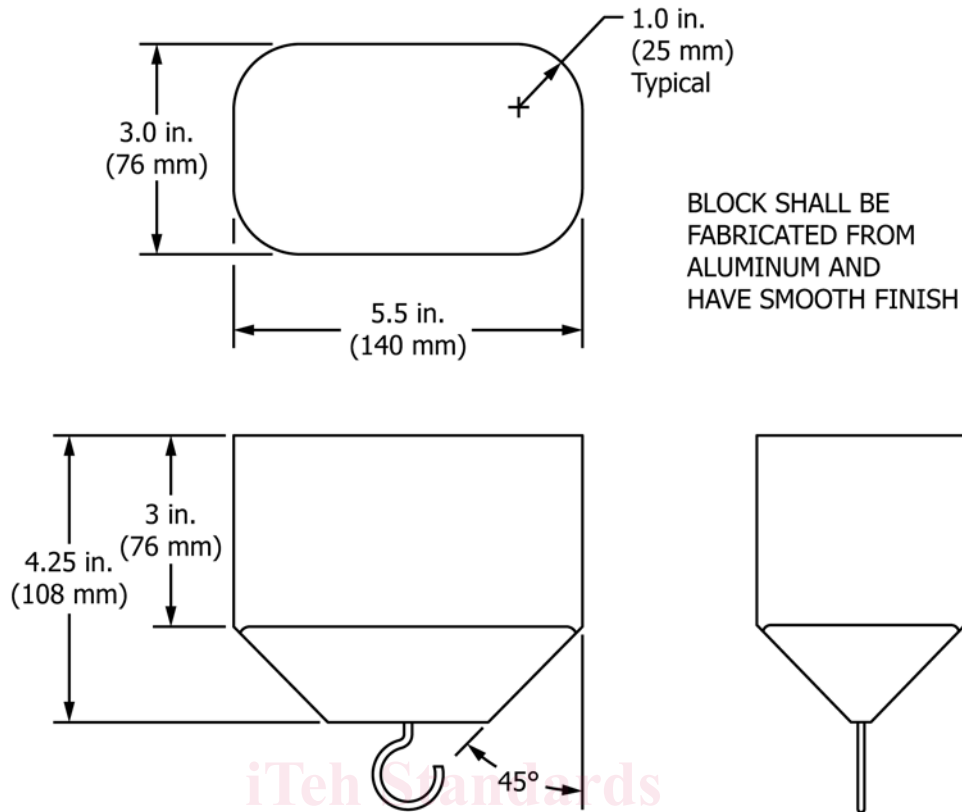

NOTE 1—Not to scale.

FIG. 2 Small Torso Probe

6.4.1 Each single-action locking or latching device shall require a minimum force of 10 lbf (45 N) to activate the release mechanism when tested in accordance with 7.6.

6.4.2 The locking or latching device shall be a double-action release mechanism. There are no force requirements for double-action locking or latching devices.

6.5 Toys:

6.5.1 Toy accessories shall not be attached to, or sold with, a gate.

6.5.2 Toy accessories attached to, removable from, or sold with an enclosure, as well as their means of attachment, shall meet applicable requirements of Specification F963.

7. Test Methods

7.1 Test Fixture—A test fixture, simulating a doorway, suitable for conducting the testing of gates shall be constructed and restrained in such a way to prohibit movement of the fixture and shall not impede the application of the load or deflection of the gate being tested. There shall be a means to adjust the width of the opening in the fixture to allow installation of the gate at the minimum and maximum opening sizes specified by the manufacturer. The height of the fixture shall be at least as tall as the gate being tested.

NOTE 1—Fig. 5 shows an example of a test fixture.

7.1.1 The vertical rigid side members of the fixture shall be faced with 1 by 4-in. (25 by 100-mm) pine boards free of knots and surface blemishes. For wall-mounted gates, the pine boards shall be replaced as needed when gate mounting hardware affects the wood surface so as to influence the test results. A board, approximately 3/4 by 1/2 in. (19 by 13 mm) shall be affixed to each of the facing boards to simulate a doorstop and to serve in positioning pressure mounted gates in the opening. All wooden components shall be painted with a semi-gloss latex paint.

7.1.2 The test fixture shall have some means to ensure that the pine boards are parallel after the width of the opening has been adjusted to accommodate a specific gate sample.

7.2 Testing Guidelines:

7.2.1 The tests under this section shall be conducted in the order shown:

- (1) Latching/Locking and Hinge Mechanism Durability Test
- (2) Automatic Closing System Test, if applicable
- (3) Remaining tests, except Slat Strength test, conducted in any order
- (4) Slat Strength Test (the last test)

7.3 Latching/Locking and Hinge Mechanism Durability Test:

Partially-bounded opening presents potential risk of head/neck entrapment

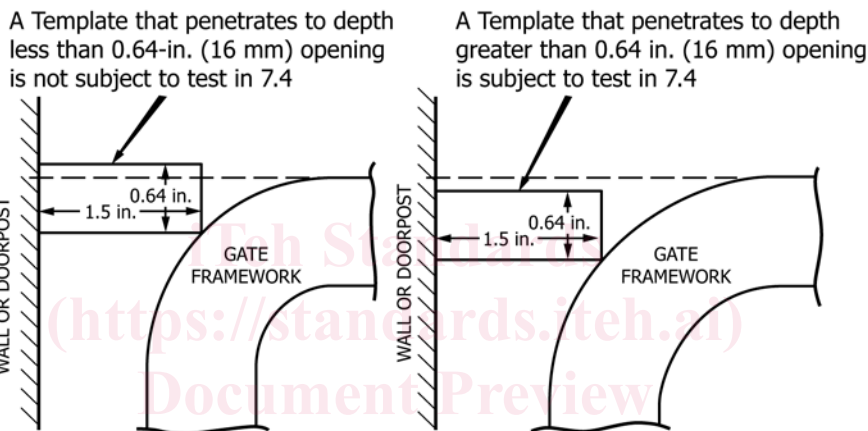
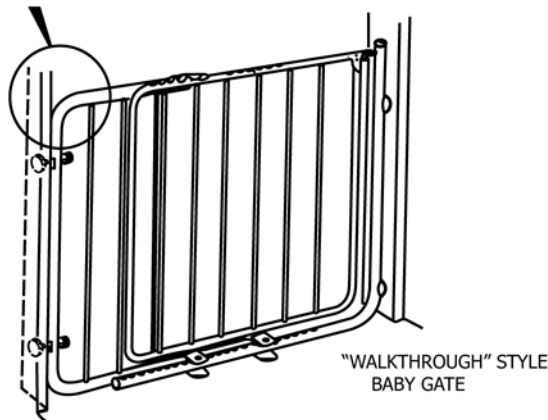

NOTE 1—Use a rectangular template to determine when a partially-bounded opening must be tested with Test Template B in accordance with 7.11.

FIG. 3 Walk-Through Style Baby Gate and Walls or Doorposts

<https://standards.iteh.ai/catalog/standards/sist/69be7f60-b700-44a4-848a-a9a0f03c4664/astm-f1004-16b>

7.3.1 Setup for Testing:

7.3.1.1 *For Testing Gates*—Install the gate in the test fixture and adjust to the maximum opening width recommended by the manufacturer. For pressure gates containing egress panels, the pressure mounts shall be rigidly connected to the test fixture so that proper pressure is maintained to hold the gate in place during the test.

NOTE 2—The purpose of this test is to cycle test hinge mechanisms and locks/latches. It is not meant to test the attachment of any pressure mount.

7.3.1.2 *For Testing Enclosures*—Assemble the enclosure according to manufacturer’s instructions and secure the section being tested to the floor such that it does not move during the tests below.

7.3.2 Mechanisms Durability Testing:

7.3.2.1 Units with egress panels shall be cycled through their normal full range of motion a total of 2000 cycles in accordance with the manufacturer’s instructions. For egress panels that open in more than one direction, the cycles shall be done half in one direction and half in the other direction. Cycling shall be conducted at a rate of no less than 12 cycles per minute. For gates equipped with automatic closing systems, perform the test at the rate of the automatic closing system.

NOTE 3—If it is found to be more efficient, test method 7.3.2 may be divided into two separate tests: 2000 cycles of testing the locking/latching mechanisms, and another 2000 cycles to test the hinge or retracting mechanism. In this case, the locking/latching mechanism should be cycled back and forth through its locked/latched position to its unlocked/unlatched position. Then, in a separate test, the durability of the hinge or retract mechanism should be tested cycling the egress panel 2000 times through its full range of motion per 7.3.2, but leaving out the step of actually locking/latching it shut between each cycle.

7.3.2.2 For pressure gates without egress panels, the locking/latching mechanism shall be cycled 550 times; a cycle consisting of removal and re-installing the gate on the test fixture.

7.4 *Automatic Closing System Test*—Following 7.3, with the unit still installed in the test fixture or secured to the floor, open the egress panel $8 \pm \frac{1}{4}$ in. (203 ± 6 mm) (See Fig. 6) and allow the panel to shut on its own. Repeat the test with the egress panel opened to its maximum allowable opening. If the gate has a hold open feature, open the gate to the point just before the hold open mechanism engages.

7.5 *Locking Mechanism Test*—For foot pedal actuated gates, apply a force of 35 lbf (156 N) in the direction tending to unlock it. The force shall be applied to the foot pedal through