



Designation: D1570 – 95 (Reapproved 2016)

# Standard Test Methods for Sampling and Chemical Analysis of Fatty Alkyl Sulfates<sup>1</sup>

This standard is issued under the fixed designation D1570; the number immediately following the designation indicates the year of original adoption or, in the case of revision, the year of last revision. A number in parentheses indicates the year of last reapproval. A superscript epsilon ( $\epsilon$ ) indicates an editorial change since the last revision or reapproval.

## 1. Scope

1.1 These test methods cover the sampling and chemical analysis of paste, powder, or liquid detergent fatty alkyl sulfates.

1.2 The procedures for sampling and analysis appear in the following order:

	Sections
Sampling:	
Powders and Flakes Packed in Cans or Cartons	4
Powders and Flakes in Bulk	5
Liquids	6
Pastes	7
Preparation of Sample	8
Moisture by the Distillation Test Method	11 – 14
pH	15
Alkalinity	16 – 19
Alcohol-Soluble Matter	20 – 22
Alcohol-Insoluble Matter	23 and 24
Unsulfated Material	25 – 28
Combined Alcohols	29 – 32
Ester SO <sub>3</sub> :	
Method A. Titration Test Method	36 and 37

	Sections
Ester SO <sub>3</sub> :	
Method B. Gravimetric Test Method	38 and 39
Sodium Sulfate	40 – 43
Chlorides Calculated as Sodium Chloride (NaCl)	44 – 47

1.3 The values stated in either inch-pound or SI units are to be regarded separately as the standard. The values given in parentheses are for information only.

1.4 *This standard does not purport to address all of the safety concerns, if any, associated with its use. It is the responsibility of the user of this standard to establish appropriate safety and health practices and determine the applicability of regulatory limitations prior to use.* Material Safety Data Sheets are available for reagents and materials. Review them for hazards prior to usage.

## 2. Referenced Documents

### 2.1 ASTM Standards:<sup>2</sup>

- D216 Method for Distillation of Natural Gasoline
- D1172 Guide for pH of Aqueous Solutions of Soaps and Detergents
- D1193 Specification for Reagent Water

<sup>1</sup> These test methods are under the jurisdiction of ASTM Committee D12 on Soaps and Other Detergents and are the direct responsibility of Subcommittee D12.12 on Analysis and Specifications of Soaps, Synthetics, Detergents and their Components.

Current edition approved July 1, 2016. Published August 2016. Originally approved in 1958 as D1570 – 58 T. Last previous edition approved in 2009 as D1570 – 95(2009). DOI: 10.1520/D1570-95R16.

<sup>2</sup> For referenced ASTM standards, visit the ASTM website, www.astm.org, or contact ASTM Customer Service at service@astm.org. For *Annual Book of ASTM Standards* volume information, refer to the standard's Document Summary page on the ASTM website.

## SAMPLING

### 3. General Requirement

3.1 The seller shall have the option of being represented at the time of sampling and when he so requests, shall be furnished with a duplicate sample.

### 4. Powders and Flakes Packed in Cans or Cartons

4.1 Take one can or carton at random from not less than 1% of the seller's shipping containers, provided each package contains not less than 50 lb (22.7 kg). In the case of smaller containers, take a can or carton at random from each lot of containers totaling not more than 5000 lb (2268 kg) or fraction

thereof. The gross sample shall in all cases consist of not less than three cans or cartons taken at random from separate containers. In the case of very large lots where the sample drawn as above will amount to more than 20 lb (9.1 kg), reduce the percentage of packages sampled so that the amount drawn will not exceed 20 lb (9.1 kg). Tightly wrap the individual cans or cartons at once in paraffined paper and seal by rubbing the edges with a heated iron. The inspector shall accurately weigh each wrapped can or carton and record its weight and the date of weighing on the wrapper. Place the wrapped cans or cartons

in an airtight container, which should be nearly filled, and which shall then be sealed, marked, and sent to the laboratory for test. Samples shall be kept cool until tested.

## 5. Powders and Flakes in Bulk

5.1 Take a grab sample of not less than 0.5 lb (227 g) at random from not less than 1 % of the seller's shipping containers, provided each package contains not less than 100 lb (45.4 kg). In the case of smaller containers, take a grab sample of not less than 0.5 lb (227 g) at random from each lot of containers totaling not more than 10 000 lb (4536 kg) or fraction thereof. The gross sample shall in all cases consist of not less than three grab samples of 0.5 lb (227 g) each taken at random from separate containers. In the case of very large lots where the sample drawn as above will amount to more than 20 lb (9.1 kg), reduce the percentage of packages sampled so that the amount drawn shall not exceed 20 lb (9.1 kg). The inspector shall rapidly mix the gross sample and place it in an airtight container, which shall be filled, sealed, accurately weighed, with its weight and the date of weighing recorded on the package, and be sent to the laboratory for test. Samples shall be kept cool until tested.

## 6. Liquids

6.1 Take a sample of not less than 0.5 pt (236.6 mL) at random from not less than 1 % of the seller's shipping containers, provided each package contains not less than 10 gal (37.9 L). In the case of smaller containers, take a sample of not less than 0.5 pt (236.6 mL) at random from each lot of containers totaling not more than 1000 gal (3785.4 L) or fraction thereof. The gross sample shall in all cases consist of not less than three samples of 0.5 pt (236.6 mL) each taken at random from separate containers. Before drawing the sample from the container selected, thoroughly agitate the contents of the container. The inspector shall thoroughly mix the gross sample, place it in clean, dry cans or bottles, which shall be completely filled and securely stoppered with clean corks or caps, then sealed, marked, and sent to the laboratory for test.

## 7. Pastes

7.1 *Pastes Packed in Cans or Cartons of 5 lb (2.27 kg) or Less*—Take one can or carton at random from not less than 1 % of the seller's shipping containers, provided each package contains not less than 50 lb (22.7 kg). In the case of smaller containers, take a can or carton at random from each lot of containers totaling not more than 5000 lb (2268 kg) or fraction thereof. The gross sample shall in all cases consist of not less than three cans or cartons taken at random from separate

containers. In the case of very large lots where the sample drawn as above will amount to more than 20 lb (9.1 kg), reduce the percentage of packages sampled so that the amount drawn shall not exceed 20 lb (9.1 kg). The samples shall be wrapped, sealed, marked, and sent to the laboratory for test.

7.2 *Pastes Packed in Bulk*—Take a “trier” sample (**Note 1**) of not less than 0.5 lb (227 g) at random from not less than 1 % of the seller's shipping containers, provided each package contains not less than 50 lb (22.7 kg). In the case of smaller containers, take a “trier” sample of not less than 0.5 lb (227 g) at random from each lot of containers totaling not more than 5000 lb (2268 kg) or fraction thereof. The gross sample shall in all cases consist of not less than three 0.5-lb (227-g) samples, each taken at random from separate containers. With very large lots where the sample drawn as above will amount to more than 10 lb (4.5 kg), reduce the percentage of packages sampled so that the amount drawn shall not exceed 10 lb (4.5 kg). The inspector shall promptly place the gross sample in a clean, dry, airtight and watertight container, which shall be filled, sealed, marked, and sent to the laboratory for test.

**NOTE 1**—A trier sample is obtained by inserting a “trier” into the material. A trier is a half-round steel cylinder  $\frac{1}{2}$  to  $\frac{3}{4}$  in. (12.7 to 19 mm) in diameter, 6 to 36 in. (152 to 914 mm) in length, pointed on one end and having a grip handle on the other end. After insertion, the trier is turned two or three times, and upon removal a core of the material being sampled is obtained.

## 8. Preparation of Sample

8.1 *Powders and Flakes*—Minimizing exposure to air, rapidly disintegrate and mix the sample of powdered, flake, or chip product. If desired, quarter down to about 1 lb (453.6 g). Weigh at once all portions for analysis, preserving the remainder in an airtight container in a cool place.

8.2 *Liquids*—No preparation of the sample of liquid, other than a thorough mixing, is necessary unless it is received during very cold weather, when it should be allowed to stand at least 1 h after it has warmed to room temperature (20 to 30°C) before it is tested, particularly for its lathering qualities (**Note 2**).

8.3 *Pastes*—Store preferably in glass. If crystals separate, melt on water bath.

**NOTE 2**—If pastes or liquids are known to be acidic, and decomposition of sample can result from heating, the samples shall be adequately labeled for precautionary treatment and warmed to room temperature or other maximum temperature as agreed upon for mixing and sampling.

TEST METHODS OF CHEMICAL ANALYSIS

9. Purity of Reagents

9.1 Reagent grade chemicals shall be used in all tests. Unless otherwise indicated, it is intended that all reagents shall conform to the specifications of the Committee on Analytical Reagents of the American Chemical Society, where such specifications are available.<sup>3</sup> Other grades may be used, provided it is first ascertained that the reagent is of sufficiently high purity to permit its use without lessening the accuracy of the determination.

9.2 Unless otherwise indicated, references to water shall be understood to mean reagent water conforming to Specification D1193.

10. Duplicate Tests

10.1 When a determination shows nonconformity with the specifications, a duplicate test shall be made.

MOISTURE BY THE DISTILLATION TEST METHOD

11. Apparatus

11.1 The apparatus shall consist of a glass flask heated by suitable means and provided with a reflux condenser discharging into a trap and connected to the flask. The connections between the trap and the condenser and flask shall be interchangeable ground joints. The trap serves to collect and measure the condensed water and to return the solvent to the flask. A suitable assembly of the apparatus is illustrated in Fig. 1.

11.1.1 *Flask*—A 1000-mL flask of either the short-neck, round-bottom type or the Erlenmeyer type.

11.1.2 *Heat Source*, either an oil bath (stearic acid, paraffin wax, etc.), or an electric heater provided with a sliding rheostat or other means of heat control.

11.1.3 *Condenser*—A water-cooled glass reflux condenser (Fig. 1), having a jacket approximately 15 3/4 in. (400 mm) in length, with an inner tube 3/8 to 1/2 in. (9.5 to 12.7 mm) in outside diameter, and not less than 1/4-in. (6-mm) inside diameter, shall be used. The end of the condenser to be inserted in the trap may be ground off at an angle of 30° from the vertical axis of the condenser. When inserted into the trap, the tip of the condenser shall be about 1/4 in. (6 mm) above the surface of the liquid in the trap after the distillation conditions have been established. Fig. 1 shows a conventional sealed-in type of condenser, but any other condenser fulfilling the detailed requirements of this paragraph may be used.

11.1.4 *Trap*—For greatest accuracy several trap sizes are allowable, depending upon the percentage of moisture expected:

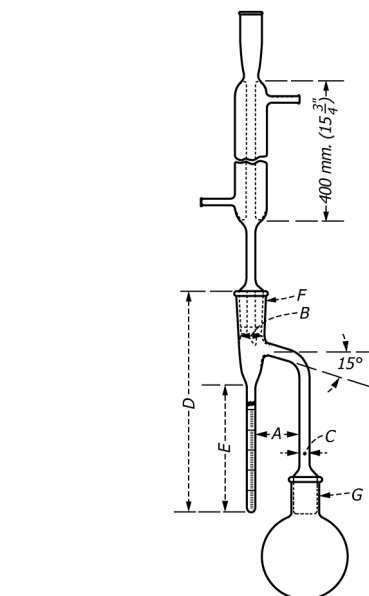

FIG. 1 Assembly of Distillation Apparatus

Moisture Expected, %	Size of Trap, mL
0 to 5, incl	5
Over 5 to 17, incl	10
Over 17 to 30, incl	10
Over 30 to 50, incl	25
Over 50 to 70, incl	25
Over 70 to 85, incl	25

Traps made of well-annealed glass, constructed essentially as shown in Fig. 1, and graduated to contain one of the following specified volumes at 20°C shall be used:

11.1.4.1 *5-mL Trap*—Subdivided into 0.1-mL divisions with each 1-mL line numbered (5 mL at top). The error in any indicated capacity may not be greater than 0.05 mL.

11.1.4.2 *10-mL Trap*—Subdivided from 0 to 1 mL in 0.1-mL divisions from 1 to 10 mL in 0.2-mL divisions.

11.1.4.3 *25-mL Trap*—Subdivided from 0 to 1 mL in 0.1-mL divisions and from 1 to 25 mL in 0.2-mL divisions.

NOTE 3—The condenser and trap should be thoroughly cleaned before use.

12. Solvent

12.1 *Xylene (or Toluene)*—Saturate xylene (or toluene) with water by shaking with a small quantity of water and distill. Use the distillate for the determination.

13. Procedure

13.1 Transfer to the 1000-mL flask, equipped with the size of trap specified in 11.1.4, an amount of sample according to the percentage of moisture expected, as follows:

<sup>3</sup> *Reagent Chemicals, American Chemical Society Specifications*, American Chemical Society, Washington, DC. For suggestions on the testing of reagents not listed by the American Chemical Society, see *Analar Standards for Laboratory Chemicals*, BDH Ltd., Poole, Dorset, U.K., and the *United States Pharmacopeia and National Formulary*, U.S. Pharmacopeial Convention, Inc. (USPC), Rockville, MD.

Moisture Expected, %	Weight of Sample to be Used, g <sup>A</sup>
0 to 5, incl	50 ± 5
Over 5 to 17, incl	50 ± 5
Over 17 to 30, incl	40 ± 4
Over 30 to 50, incl	30 ± 3
Over 50 to 70, incl	30 ± 3
Over 70 to 85, incl	25 ± 2

<sup>A</sup> Weighed to the nearest 0.25 g.

Add immediately about 100 mL of xylene or toluene. Place a small, thin sheet of long-fiber, chemical-resistant glass 328<sup>4</sup> on the surface of the toluene. The glass wool should be thoroughly dried in the oven and held in the desiccator before use.

13.2 Connect the flask and receiver to the condenser and pour sufficient xylene or toluene down the condenser tube to cause a slight overflow through the side tube. Wrap the flask and tube leading to the receiver with asbestos cloth, so that refluxing will be under better control.

13.3 Heat the oil bath with a gas burner or other source of heat, or apply heat directly to the flask with an electric heater and distill slowly. The rate at the start should be approximately 100 drops/min. When the greater part of the water has distilled over, increase the distillation rate to 200 drops/min until no more water is collected. Purge the reflux condenser during the distillation with 5-mL portions of xylene (or toluene) to wash down any moisture adhering to the walls of the condenser. The water in the receiver may be made to separate from the xylene (or toluene) by using a spiral copper or nichrome wire. Move the wire up and down in the condenser occasionally, thus causing the water to settle at the bottom of the receiver. Reflux for at least 2 h, and shut off the heat at the end of this period.

13.4 Wash down condenser with 1 mL of absolute ethanol (CH<sub>3</sub>CH<sub>2</sub>OH). Adjust the temperature of the distillate to 20°C and read the volume of water.

#### 14. Calculation

14.1 Calculate the percentage of moisture as follows:

$$\text{Moisture, \%} = [(V \times 0.998)/W] \times 100 \quad (1)$$

where:

*V* = volume of water, mL at 20°C, and

*W* = weight of the sample, g.

#### pH

#### 15. Procedure

15.1 Determine pH in accordance with Test Method D1172, except that the measurement shall be made 10 min after adjusting the solution of the sample to volume.

#### ALKALINITY

#### 16. Apparatus

16.1 *Buret.*

16.2 *Beaker, 400-mL.*

<sup>4</sup> Borosilicate glass has been found satisfactory for this purpose.

#### 17. Reagents

17.1 *Hydrochloric or Sulfuric Acid, Standard*—Prepare and standardize 1 *N* hydrochloric acid or sulfuric acid. Hydrochloric acid is preferable. Standard acid weaker than 1 *N* may be used and titrations calculated to the equivalent in terms of 1 *N* solution.

17.2 *Indicator Solutions*—Phenolphthalein and methyl orange indicator solutions.

17.3 *Sodium Hydroxide, Standard Solution 1.0 N*—Prepare and standardize a 1.0 *N* NaOH solution. A 0.5 *N* NaOH solution may be used with proper corrections in calculation.

#### 18. Procedure

18.1 Weigh  $5 \pm 0.001$  g of the sample into a 400-mL beaker. Dissolve in 100 to 150 mL of warm water (about 35°C). Add 2 drops of methyl orange indicator and 2 drops of phenolphthalein indicator and titrate in accordance with 18.2, 18.3, or 18.4.

18.2 If the sample solution is acid to methyl orange, titrate with 1 *N* NaOH solution to the methyl orange end point.

18.3 If the sample solution is alkaline to methyl orange and acid to phenolphthalein, titrate with 1 *N* acid to the methyl orange end point.

18.4 If the sample solution is alkaline to phenolphthalein, titrate with 1 *N* acid first to the phenolphthalein end point and then to the methyl orange end point.

#### 19. Calculation

19.1 Calculate the alkalinity to the appropriate basis, as follows:

19.1.1 If the sample solution was acid to methyl orange (18.2), calculate the alkalinity to sodium bisulfate (NaHSO<sub>4</sub>) as follows:

$$\text{NaHSO}_4, \% = M_b \times 2.402 \quad (2)$$

where:

*M<sub>b</sub>* = millilitres of 1 *N* NaOH solution required for titration of the sample.

19.1.2 If the sample solution was alkaline to methyl orange and acid to phenolphthalein (18.3), calculate the alkalinity to sodium bicarbonate (NaHCO<sub>3</sub>) as follows:

$$\text{NaHCO}_3, \% = A \times 1.68 \quad (3)$$

where:

*A* = millilitres of 1 *N* acid required for titration of the sample.

19.1.3 If the sample solution was alkaline to phenolphthalein (18.4), calculate the alkalinity to sodium hydroxide (NaOH), sodium carbonate (Na<sub>2</sub>CO<sub>3</sub>), or sodium bicarbonate (NaHCO<sub>3</sub>) as follows:

19.1.3.1 If twice the amount of acid required for titration to the phenolphthalein end point, minus the amount of acid required for titration to the methyl orange end point, is more than zero, then:



$$NaOH, \% = (2P - M_a) \times 0.80 \quad (4)$$

$$Na_2CO_3, \% = 2(M_a - P) \times 1.06$$

where:

$M_a$  = millilitres of 1 *N* acid required for titration of the sample to the methyl orange end point, and

$P$  = millilitres of 1 *N* acid required for titration of the sample to the phenolphthalein end point.

19.1.3.2 If twice the amount of acid required for titration to the phenolphthalein end point, minus the amount of acid required for titration to the methyl orange end point, is zero or less than zero, then:

$$Na_2CO_3, \% = 2P \times 1.06 \quad (5)$$

$$NaHCO_3, \% = (M_a - 2P) \times 1.68$$

## ALCOHOL-SOLUBLE MATTER

### 20. Reagents

20.1 *Ethyl Alcohol (95 %)*—Ethyl alcohol conforming to Formula No. 30 or 3A of the U.S. Bureau of Internal Revenue. The alcohol should not be neutralized. Use redistilled alcohol if alkali absorption is more than 0.2 mL.

20.2 *Ethyl Alcohol (absolute)*—Freshly boiled absolute ethyl alcohol conforming to either Formula No. 30 or 3A of the U.S. Bureau of Internal Revenue.

### 21. Procedure

21.1 For pastes or liquids, weigh approximately 20 g to the nearest 1 mg and wash into a 400-mL anti-bump beaker with ethyl alcohol (absolute). For powders, weigh 10 g to the nearest 1 mg and transfer to a 400-mL antibump beaker.

21.2 Add 300 to 350 mL of hot absolute ethyl alcohol. Cover with a watch glass and heat on the steam bath for at least 2 h, stirring frequently to disperse solids and break up lumps. Have ready a tared Gooch or sintered glass crucible.

21.3 At the end of 2 h, remove the beaker from the bath and filter the supernatant liquid through the tared Gooch crucible, with suction, into a 800-mL beaker, retaining as much as possible of the residue in the beaker. Add 50 mL of hot ethyl alcohol (95 %) to the residue in the beaker. Heat to boiling on a hot plate, breaking up any lumps of the residue. Again decant the alcohol through the tared filter as before. Repeat again with another 50-mL portion of hot alcohol (95 %).

21.4 Evaporate the residual alcohol from the residue in the beaker on the steam bath, stirring at intervals, especially near the end. Dissolve the residue in the beaker with 10 mL of hot water, heating on the steam bath until solution is effected. Dilute the water solution with 200 mL of hot ethyl alcohol (absolute), bring to a boil on the steam bath, and filter through the original tared Gooch. Finally, transfer the precipitate to the Gooch with the aid of hot alcohol (absolute) and a policeman.

21.5 Wash the residue with hot ethyl alcohol (95 %). Three or four washings will be required. Combine the filtrate and washings in a 1-L volumetric flask, cool, make up to volume with alcohol (95 %), and mix thoroughly.

21.6 Transfer a 200-mL aliquot to a tared Soxhlet flask. Evaporate on the steam bath in a gentle stream of clean, dry, oilfree air, until the residue has no odor of alcohol. Swirl the flask to bring the residue onto the sides of the flask to aid the escape of moisture. Dry 2 h in the oven at 90°C. Cool in a desiccator and weigh. Break up residue with a glass rod. Return to the oven for ½ h, cool, and reweigh. Repeat until constant weight is obtained.

### 22. Calculation

22.1 Calculate the uncorrected percentage of alcohol soluble matter as follows:

$$\text{Alcohol - soluble matter (uncorrected), \%} = (A/B) \times 100 \quad (6)$$

where:

$A$  = grams of residue, and

$B$  = grams of sample represented by the aliquot used.

## ALCOHOL-INSOLUBLE MATTER

### 23. Procedure

23.1 Air dry the Gooch and residue from the alcohol-soluble matter to remove residual alcohol and place it in a  $105 \pm 2^\circ\text{C}$  oven for 2 h or longer and dry to constant weight. Cool in a desiccator and weigh.

### 24. Calculation

24.1 Calculate the percentage of alcohol-insoluble matter as follows:

$$\text{Alcohol - insoluble matter, \%} = [(A - B)/C] \times 100 \quad (7)$$

where:

$A$  = weight of residue and Gooch, g,

$B$  = weight of Gooch, g, and

$C$  = grams of sample used.

## UNSULFATED MATERIAL

### 25. Apparatus

25.1 *Extraction Cylinder or Stokes Flask*, 250-mL.

25.2 *Separatory Funnel*, 250-mL.

25.3 *Soxhlet Flask*, 250-mL.

### 26. Reagents

26.1 *Ethyl Alcohol*—Denatured ethyl alcohol conforming to Formula No. 30 or 3A of the Bureau of Internal Revenue.

26.2 *Petroleum Ether*—The solvent used shall be of the pentane type, containing a minimum amount of isopentane, isohexane, and hexane, conforming to the following requirements:

Distillation test: <sup>a</sup>	
Initial boiling point	35 to 38°C
Dry flask end point	52 to 60°C
Distilling under 54°C, min	95 %
Distilling under 40°C, max	60 %
Specific gravity at 15.5/15.5°C (60/60°F)	0.630 to 0.660
Color	water white
Doctor test	sweet
Evaporation residue, 100 mL, max	0.0011 g

Copper-strip corrosion test <sup>B</sup>	noncorrosive
Unsaturated compounds <sup>C</sup>	trace only permitted
Residue in distilling flask	neutral to methyl orange
Blotter-strip odor test <sup>D</sup>	odorless within 12 min
Aromatic compound <sup>E</sup>	no nitrobenzene odor
Saponification value	less than 1.0 mg KOH/100 mL

<sup>A</sup> Distillation test shall be made in accordance with Method D216. As a check on the evaporation residue, 250 mL of the petroleum ether and 0.25 g of stearin or other hard fat (previously brought to constant weight by heating) when dried as in the actual determination shall not show an increase in weight exceeding 0.003 g.

<sup>B</sup> Copper-strip corrosion test shall be made by inserting a small polished copper strip into the petroleum ether in the distilling flask. There should be no appreciable darkening of the copper.

<sup>C</sup> Unsaturated compounds shall be determined by the method for determining olefins as described in *Industrial and Engineering Chemistry*, Analytical Edition, IENAA, March 15, 1938, p. 154.

<sup>D</sup> Odor test: Immerse 1 in. (25 mm) of a strip of white unglazed blotting paper, approximately 1 by 4 by 0.166 in. (25 by 102 by 4 mm) in size, in the petroleum ether for 30 s, remove the strip, and allow to dry at room temperature in still air for 12 min.

<sup>E</sup> Aromatic compounds: Add 5 drops of petroleum ether to 40 drops of concentrated sulfuric acid (H<sub>2</sub>SO<sub>4</sub>, sp gr 1.84) and 10 drops of concentrated nitric acid (HNO<sub>3</sub>, sp gr 1.42) in a test tube, warm for 10 min, allow to cool for 30 min, transfer to a shallow dish, and dilute with water.

26.3 *Potassium Hydroxide Solution (50 %)*—Dissolve potassium hydroxide (KOH) in an equal weight of water.

26.4 *Monosodium Phosphate*—(NaH<sub>2</sub>PO<sub>4</sub>).

## 27. Procedure

27.1 Use the alcohol-soluble matter from Section 18 by selecting an aliquot of suitable size; or weigh, to the nearest 1 mg, approximately 20 g of the sample matter for pastes or liquids, or 10 g for powder. For a dry product, dissolve in about 50 mL of hot alcohol and transfer to a 250-mL extraction cylinder, using sufficient alcohol to bring the volume to 80 mL. When the product is liquid or paste, wash from the weighing dish with hot alcohol until the volume of alcohol equals 80 mL. Add sufficient KOH solution to make distinctly alkaline to phenolphthalein. Then continue washing with hot water. Add sufficient water to bring to the 150-mL mark. Cool well below the boiling point of the solvent.

27.2 Extract with petroleum ether at least five times using 50-mL portions. Shake each extraction vigorously for ½ min. Allow to settle well between extractions. Addition of a few grams of NaH<sub>2</sub>PO<sub>4</sub> crystals will eliminate emulsion difficulties (Note 3). Draw off the petroleum ether layers into a small separatory funnel. Add 30 mL of water and shake to mix the two layers. Draw off the water layer. Transfer a portion of the petroleum ether layer to a tared 150-mL Soxhlet flask and reduce the volume by evaporation in a gentle current of dry oil-free air on top of the steam bath (but do not dry). Complete the transfer of the petroleum ether layer and continue evaporation until no order of petroleum ether remains. The Soxhlet flask must be removed at once as soon as petroleum ether has evaporated. A white mist in the neck of the flask is often noticeable when the solvent has evaporated. *Prolonged heating must be avoided* because the residue is readily volatilized. Cool in a desiccator and weigh.

NOTE 4—Disodium phosphate Na<sub>2</sub>HPO<sub>4</sub> should not be used if any kind of soaps are present.

## 28. Calculation

28.1 Calculate the percentage of unsulfated material as follows:

28.1.1 If a portion of the alcohol-soluble matter is used:

$$A = (B \times C)/D \quad (8)$$

where:

- A = percentage of petroleum ether extract in the alcohol-soluble matter on the basis of the original sample,
- B = percentage of alcohol-soluble matter,
- C = grams of residue, and
- D = grams of sample used (or grams of sample represented by the aliquot used, on the basis of alcohol-soluble matter).

28.1.2 If a fresh sample is used:

$$A = (B/C) \times 100 \quad (9)$$

where:

- A = percentage of petroleum ether extract of free alcohols in sample,
- B = grams of residue, and
- C = grams of sample used.

## COMBINED ALCOHOLS

## 29. Apparatus

29.1 *Reflux Condenser*, Allihn or Liebig type, water-cooled, at least 12 in. (305 mm) long.

29.2 *Flask*—A 250 to 300-mL round-bottom flask with a ground-glass connection to fit the condenser is preferred. A tight cork stopper may be used.

29.3 *Burets*.

29.4 *Miscellaneous Equipment*—A 250-mL extraction cylinder, separatory funnel, Soxhlet flask, siphon, etc.

## 30. Reagents

30.1 *Water-Alcohol Wash Solution*—Mix 1 volume of ethyl alcohol (95 %) with 9 volumes of water.

30.2 *Hydrochloric Acid (sp gr 1.19)*—Concentrated hydrochloric acid (HCl).

30.3 *Hydrochloric Acid, Standard (1.0 N)*—Prepare and standardize 1.0 N HCl.

30.4 *Indicator Solutions*—Methyl orange and phenolphthalein indicator solutions.

30.5 *Petroleum Ether*—See 25.2.

30.6 *Potassium Hydroxide, Alcoholic Solution (0.5 N)*—Prepare and standardize a 0.5 N alcoholic KOH solution.

## 31. Procedure

31.1 Weigh a portion of the sample estimated to yield from 1 to 3 g of alcohols into a 250-mL or other hydrolyzing flask. Dissolve in 50 to 60 mL of water. Add 2 to 3 drops of methyl orange indicator solution and carefully titrate with standard HCl or KOH solution to the methyl orange end point (Note 4). Add 50 mL of 1 N HCl, or more if necessary, measuring the amount added accurately.