



Designation: ~~E2007~~—~~10~~ **E2007 – 10 (Reapproved 2016)**

Standard Guide for Computed Radiography¹

This standard is issued under the fixed designation E2007; the number immediately following the designation indicates the year of original adoption or, in the case of revision, the year of last revision. A number in parentheses indicates the year of last reapproval. A superscript epsilon (ϵ) indicates an editorial change since the last revision or reapproval.

1. Scope

1.1 This guide provides general tutorial information regarding the fundamental and physical principles of computed radiography (CR), definitions and terminology required to understand the basic CR process. An introduction to some of the limitations that are typically encountered during the establishment of techniques and basic image processing methods are also provided. This guide does not provide specific techniques or acceptance criteria for specific end-user inspection applications. Information presented within this guide may be useful in conjunction with those standards of 1.2.

1.2 CR techniques for general inspection applications may be found in Practice E2033. Technical qualification attributes for CR systems may be found in Practice E2445. Criteria for classification of CR system technical performance levels may be found in Practice E2446. Reference Images Standards E2422, E2660, and E2669 contain digital reference acceptance illustrations.

1.3 The values stated in SI units are to be regarded as the standard. The inch-pound units given in parentheses are for information only.

1.4 *This standard does not purport to address all of the safety concerns, if any, associated with its use. It is the responsibility of the user of this standard to establish appropriate safety and health practices and determine the applicability of regulatory limitations prior to use.*

2. Referenced Documents

2.1 ASTM Standards:²

- E94 Guide for Radiographic Examination
- E746 Practice for Determining Relative Image Quality Response of Industrial Radiographic Imaging Systems
- E747 Practice for Design, Manufacture and Material Grouping Classification of Wire Image Quality Indicators (IQI) Used for Radiology
- E1025 Practice for Design, Manufacture, and Material Grouping Classification of Hole-Type Image Quality Indicators (IQI) Used for Radiology
- E1316 Terminology for Nondestructive Examinations
- E1453 Guide for Storage of Magnetic Tape Media that Contains Analog or Digital Radioscopic Data
- E2002 Practice for Determining Total Image Unsharpness and Basic Spatial Resolution in Radiography and Radioscopy
- E2033 Practice for Computed Radiology (Photostimulable Luminescence Method)
- E2339 Practice for Digital Imaging and Communication in Nondestructive Evaluation (DICONDE)
- E2422 Digital Reference Images for Inspection of Aluminum Castings
- E2445 Practice for Performance Evaluation and Long-Term Stability of Computed Radiography Systems
- E2446 Practice for Manufacturing Characterization of Computed Radiography Systems
- E2660 Digital Reference Images for Investment Steel Castings for Aerospace Applications
- E2669 Digital Reference Images for Titanium Castings

2.2 SMPTE Standard:

- RP-133 Specifications for Medical Diagnostic Imaging Test Pattern for Television Monitors and Hard-Copy Recording Cameras³

¹ This guide is under the jurisdiction of ASTM Committee E07 on Nondestructive Testing and is the direct responsibility of Subcommittee E07.01 on Radiology (X and Gamma) Method.

Current edition approved June 1, 2010/July 1, 2016. Published July 2010/July 2016. Originally approved in 1999. Last previous edition approved in 2008/2010 as E2007-08/E2007-10. DOI: 10.1520/E2007-10.1520/E2007-10R16.

² For referenced ASTM standards, visit the ASTM website, www.astm.org, or contact ASTM Customer Service at service@astm.org. For *Annual Book of ASTM Standards* volume information, refer to the standard's Document Summary page on the ASTM website.

³ Available from Society of Motion Picture and Television Engineers (SMPTE), 3 Barker Ave, 5th Floor, White Plains, NY 10601.

3. Terminology

3.1 Unless otherwise provided within this guide, terminology is in accordance with Terminology E1316.

3.2 Definitions:

3.2.1 *aliasing*—artifacts that appear in an image when the spatial frequency of the input is higher than the output is capable of reproducing. This will often appear as jagged or stepped sections in a line or as moiré patterns.

3.2.2 *basic spatial resolution (SR_b)*—terminology used to describe the smallest degree of visible detail within a digital image that is considered the effective pixel size.

3.2.2.1 Discussion—

The concept of basic spatial resolution involves the ability to separate two distinctly different image features from being perceived as a single image feature. When two identical image features are determined minimally distinct, the single image feature is considered the effective pixel size. If the physical sizes of the two distinct features are known, for example, widths of two parallel lines or bars with an included space equal to one line or bar, then the effective pixel size is considered $\frac{1}{2}$ of their sums. Example: A digital image is determined to resolve five line pairs per mm or a width of line equivalent to five distinct lines within a millimetre. The basic spatial resolution is determined as $1/[2 \times 5 \text{ LP/mm}]$ or 0.100 mm.

3.2.3 *binary/digital pixel data*—a matrix of binary (0's, 1's) values resultant from conversion of PSL from each latent pixel (on the IP) to proportional (within the bit depth scanned) electrical values. Binary digital data value is proportional to the radiation dose received by each pixel.

3.2.4 *bit depth*—the number “2” increased by the exponential power of the analogue-to-digital (A/D) converter resolution. Example 1) In a 2-bit image, there are four (2^2) possible combinations for a pixel: 00, 01, 10 and 11. If “00” represents black and “11” represents white, then “01” equals dark gray and “10” equals light gray. The bit depth is two, but the number of gray scales shades that can be represented is 2^2 or 4. Example 2): A 12-bit A/D converter would have 4096 (2^{12}) gray scales shades that can be represented.

3.2.5 *blooming or flare*—an undesirable condition exhibited by some image conversion devices brought about by exceeding the allowable input brightness for the device, causing the image to go into saturation, producing an image of degraded spatial resolution and gray scale rendition.

3.2.6 *computed radiographic system*—all hardware and software components necessary to produce a computed radiograph. Essential components of a CR system consisting of: an imaging plate, an imaging plate readout scanner, electronic image display, image storage and retrieval system and interactive support software.

3.2.7 *computed radiographic system class*—a group of computed radiographic systems characterized with a standard image quality rating. Practice E2446, Table 1, provides such a classification system.

3.2.8 *computed radiography*—a radiological nondestructive testing method that uses storage phosphor imaging plates (IP's), a PSL stimulating light source, PSL capturing optics, optical-to-electrical conversion devices, analogue-to-digital data conversion electronics, a computer and software capable of processing original digital image data and a means for electronically displaying or printing resultant image data.

3.2.9 *contrast and brightness*—an application of digital image processing used to “re-map” displayed gray scale levels of an original gray scale data matrix using different reference lookup tables.

3.2.9.1 Discussion—

This mode of image processing is also known as “windowing” (contrast adjustment) and “leveling” (brightness adjustment) or simply “win-level” image processing.

3.2.10 *contrast-to-noise ratio (CNR)*—quotient of the digital image contrast (see 3.2.13) and the averaged standard deviation of the linear pixel values.

3.2.10.1 Discussion—

CNR is a measure of image quality that is dependent upon both digital image contrast and signal-to-noise ratio (SNR) components. In addition to CNR, a digital radiograph must also possess adequate sharpness or basic spatial resolution to adequately detect desired features.

3.2.11 *digital driving level (DDL)*—terminology used to describe displayed pixel brightness of a digital image on a monitor resultant from digital mapping of various gray scale levels within specific look-up-table(s).

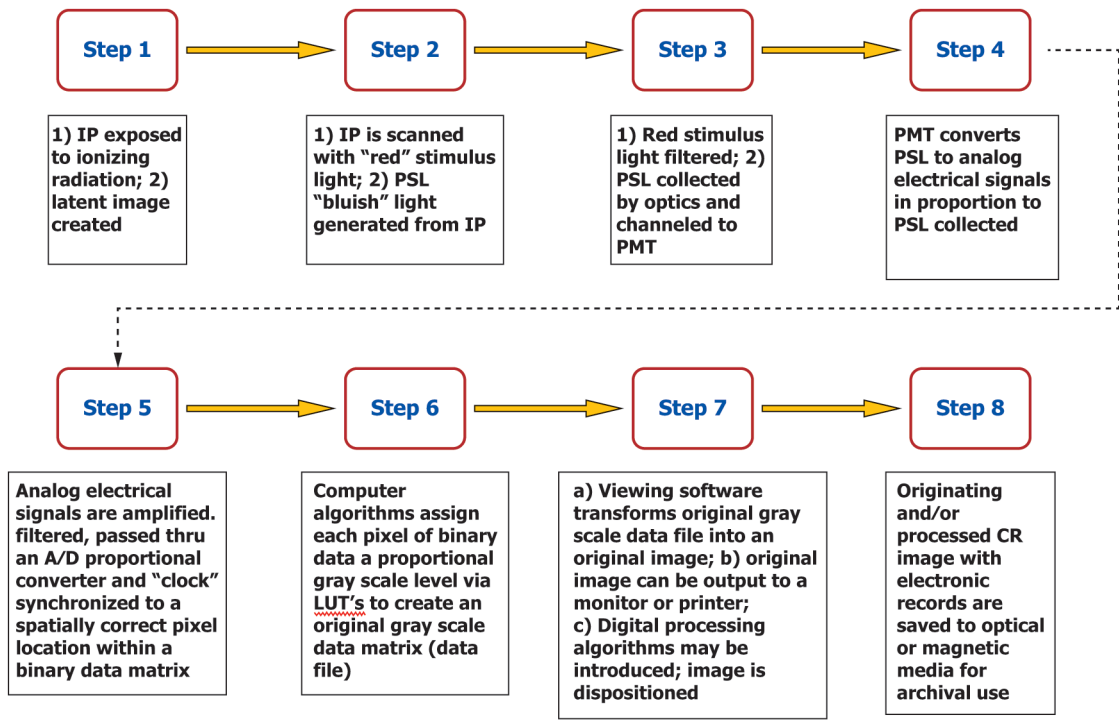

FIG. 1 Basic Computed Radiography Process

3.2.11.1 Discussion—

DDL is also known as monitor pixel intensity value; thus, may not be the PV of the original digital image.

3.2.12 *digital dynamic range*—maximum material thickness latitude that renders acceptable levels of specified image quality performance within a specified pixel intensity value range.

3.2.12.1 Discussion—

<https://standards.iteh.ai/catalog/standards/sist/d3f9f76e-04fc-46d4-afc7-1f2c2bc471c5/astm-e2007-102016>

Digital dynamic range should not be confused with computer file bit depth.

3.2.13 *digital image contrast*—pixel value difference between any two areas of interest within a computed radiograph.

3.2.13.1 Discussion—

digital contrast = $PV2 - PV1$ where PV2 is the pixel value of area of interest "2" and PV1 is the pixel value of area of interest "1" on a computed radiograph. Visually displayed image contrast can be altered via digital re-mapping (see 3.2.11) or re-assignment of specific gray scale shades to image pixels.

3.2.14 *digital image noise*—imaging information within a computed radiograph that is not directly correlated with the degree of radiation attenuation by the object or feature being examined and/or insufficient radiation quanta absorbed within the detector IP.

3.2.14.1 Discussion—

Digital image noise results from random spatial distribution of photons absorbed within the IP and interferes with the visibility of small or faint detail due to statistical variations of pixel intensity value.

3.2.15 *digital image processing*—the use of algorithms to change original digital image data for the purpose of enhancement of some aspect of the image.

3.2.15.1 Discussion—

Examples include: contrast, brightness, pixel density change (digital enlargement), digital filters, gamma correction and pseudo colors. Some digital processing operations such as sharpening filters, once saved, permanently change the original binary data matrix (Fig. 1, Step 5).

3.2.16 *equivalent penetrameter sensitivity (EPS)*—that thickness of penetrameter, expressed as a percentage of the section thickness radiographed, in which a 2T hole would be visible under the same radiographic conditions. EPS is calculated by: $EPS\% = 100/X (\sqrt{Th/2})$, where: h = hole diameter, T = step thickness and X= thickness of test object (see E1316, E1025, E747, and Practice E746).

3.2.17 *gray scale*—a term used to describe an image containing shades of gray rather than color. Gray scale is the range of gray shades assigned to image pixels that result in visually perceived pixel display brightness.

3.2.17.1 *Discussion*—

The number of shades is usually positive integer values taken from the bit depth. For example: an 8-bit gray scale image has up to 256 total shades of gray from 0 to 255, with 0 representing white image areas and 255 representing black image areas with 254 shades of gray in between.

3.2.18 *image morphing*—a potentially degraded CR image resultant from over processing (that is, over driving) an original CR image.

3.2.18.1 *Discussion*—

“Morphing” can occur following several increments of image processing where each preceding image was “overwritten” resulting in an image that is noticeably altered from the original.

3.2.19 *look up table (LUT)*—one or more fields of binary digital values arbitrarily assigned to a range of reference gray scale levels (viewed on an electronic display as shades of “gray”).

3.2.19.1 *Discussion*—

A LUT is used (applied) to convert binary digital pixel data to proportional shades of “gray” that define the CR image. LUT’s are key reference files that allow binary digital pixel data to be viewed with many combinations of pixel gray scales over the entire range of a digital image (see Fig. 5-A).

3.2.20 *original digital image*—a digital gray scale (see 3.2.17) image resultant from application of original binary digital pixel data to a linear look-up table (see 3.2.24 and 3.2.19 prior to any image processing).

<https://standards.iteh.ai/catalog/standards/sist/d319f76e-04fc-46d4-afc7-1f2c2bc471c5/astm-e2007-102016>

3.2.20.1 *Discussion*—

This original gray scale image is usually considered the beginning of the “computed radiograph”, since without this basic conversion (to gray scales) there would be no discernable radiographic image (see Fig. 5-B).

3.2.21 *photostimulable luminescence (PSL)*—photostimulable luminescence (PSL) is a physical phenomenon in which a halogenated phosphor compound emits bluish light when excited by a source of red spectrum light.

3.2.22 *pixel brightness*—the luminous (monitor) display intensity of pixel(s) that can be controlled by means of electronic monitor brightness level settings or changes of digital driving level (see 3.2.11).

3.2.23 *pixel density*—the number of pixels within a digital image of fixed dimensions (that is, length and width).

3.2.23.1 *Discussion*—

for digital raster images, the convention is to describe pixel density in terms of the number of pixel-columns (width) and number of pixel rows (height). An alternate convention is to describe the total number of pixels in the image area (typically given as the number of mega pixels), which can be calculated by multiplying pixel-columns by pixel-rows. Another convention includes describing pixel density per area-unit or per length-unit such as pixels per in./mm. Resolution (see 7.1.5) of a digital image is related to pixel density.

3.2.24 *pixel value (PV)*—a positive integer numerical value directly associated with each binary picture data element (pixel) of an original digital image where gray scale shades (see 3.2.17) are assigned in linear proportion to radiation exposure dose received by that area.

3.2.24.1 *Discussion*—

Computed radiography uses gray scale shades to render visual perceptions of image contrast; thus, linear pixel value (PV) is used to measure a specific shade of gray that corresponds to the quantity of radiation exposure absorbed within a particular area of a part. With this relationship, a PV of “0” can correspond with “0” radiation dose (white image area of a negative image view) whereas a PV of “4095” can correspond with a saturated detector (black image area of a negative image view) for a 12 bit CR system. PV is directly related to original binary pixel data via a common linear look-up-table (Fig. 5 A and B illustrate). The number of available pixel value integers within an image is associated with the number of available gray scale shades for the bit depth of the image.

3.2.25 *PSL afterglow*—continued luminescence from a storage phosphor immediately following removal of an external photostimulating source.

3.2.25.1 *Discussion*—

A bluish luminescence continues for a short period of time after termination of the photostimulating source as illustrated in Fig. 12.

3.2.26 *relative image quality response (RIQR)*—a means for determining the image quality performance response of a given radiological imaging system in relative comparison to the image quality response of another radiological imaging system.

3.2.26.1 *Discussion*—

RIQR methods are not intended as a direct measure of image quality for a specific radiographic technique application. Practice E746 provides a standard RIQR method.

3.2.27 *signal-to-noise ratio (SNR)*—quotient of mean linear pixel value and standard deviation of mean linear pixel values (noise) for a defined detector area-of-interest in a digital image.

3.2.27.1 *Discussion*—

Notwithstanding extraneous sources of digital image noise, SNR will normally increase as exposure dose is increased.

3.2.28 *spatial resolution*—terminology used to define a component of optical image quality associated with distinction of closely spaced adjacent multiple features.

3.2.28.1 *Discussion*—

The concept of optical resolution involves the ability to separate multiple closely spaced components, for example, optical line pairs, into two or more distinctly different components within a defined unit of space. Example: an optical imaging system that is said to resolve two line pairs within one mm of linear space (that is, 2 Lp/mm) contains five individual components: two closely spaced adjacent line components, an intervening space between the lines and space on the outside boundaries of the two lines.

3.2.29 *storage phosphor imaging plate (IP)*—a photostimulable luminescent material that is capable of storing a latent radiographic image of a material being examined and, upon stimulation by a source of red spectrum light, will generate luminescence (PSL) proportional to radiation absorbed.

3.2.29.1 *Discussion*—

When performing computed radiography, an IP is used in lieu of a film. When establishing techniques related to source focal geometries, the IP is referred to as a detector (i.e. source-to detector-distance or SDD).

3.2.30 *unsharpness*—terminology used to describe an attribute of image quality associated with blurring or loss of distinction within a radiographic image.

3.2.30.1 *Discussion*—

Measured total unsharpness is described with a numerical value corresponding with a measure of definition (that is, distinction) associated with the geometry of exposure and inherent unsharpness of the CR system (that is, inherent or total unsharpness). Guide E94 provides fundamental guidance related to geometrical unsharpness and Practice E2002 provides a standard practice for measurement of total unsharpness.

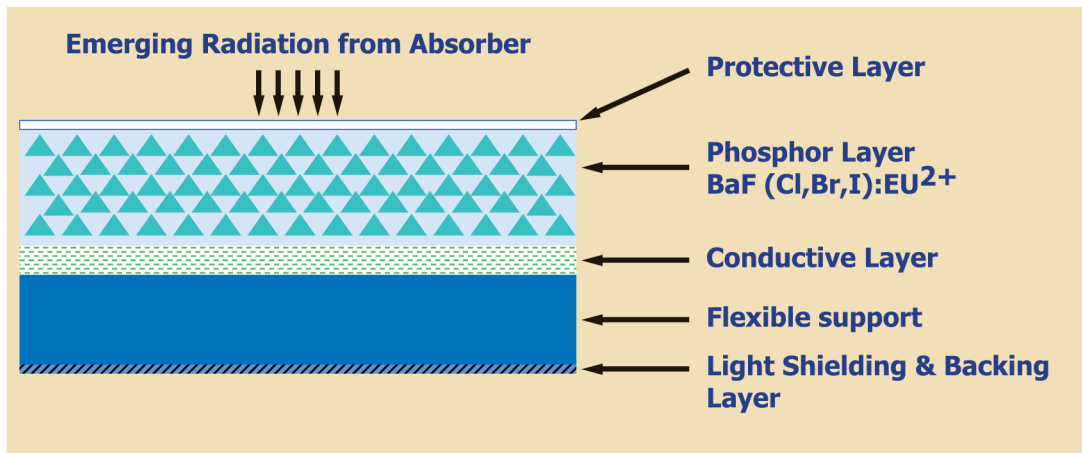

Illustration courtesy of Fujifilm NDT Systems

FIG. 2 Cross Section of a Typical Storage Phosphor Imaging Plate

4. Significance and Use

4.1 This guide is intended as a source of tutorial and reference information that can be used during establishment of computed radiography techniques and procedures by qualified CR personnel for specific applications. All materials presented within this guide may not be suited for all levels of computed radiographic personnel.

4.2 This guide is intended to build upon an established basic knowledge of radiographic fundamentals (that is, film systems) as may be found in Guide E94. Similarly, materials presented within this guide are not intended as “all-inclusive” but are intended to address basic CR topics and issues that complement a general knowledge of computed radiography as described in 1.2 and 3.2.28.

4.3 Materials presented within this guide may be useful in the development of end-user training programs designed by qualified CR personnel or activities that perform similar functions. Computed radiography is considered a rapidly advancing inspection technology that will require the user maintain knowledge of the latest CR apparatus and technique innovations. Section 11 of this guide contains technical reference materials that may be useful in further advancement of knowledge associated with computed radiography.

5. Computed Radiography Fundamentals

5.1 This section introduces and describes primary core components and processes of a basic computed radiography process. The user of this standard guide is advised that computed radiography is a rapidly evolving technology where innovations involving core steps and processes are continually under refinement. Tutorial information presented in this section is intended to illustrate the fundamental computed radiography process and not necessarily any specific commercial CR system.

5.2 *Acquiring the CR Image:* Computed radiography (CR) is one of several different modes of digital radiography that employs re-usable photostimulable luminescence (PSL) storage phosphor imaging plates (commonly called IP’s) for acquisition of radiographic images. Figure 1 illustrates an example of the fundamental steps of a basic CR process arrangement.

In this illustration, a conventional (that is, Guide E94) radiographic exposure geometry/arrangement is used to expose a part positioned between the radiation source and IP. *Step 1* involves exposure of the IP (Fig. 2 illustrates typical cross section details of an IP) and creation of a residual latent image with delayed luminescence properties (Section 6 details physics).

Step 2 involves index scanning the exposed IP with a stimulus source of red light from a laser beam (Fig. 3 illustrates Steps 2 through 8).

During the scan, the IP is stimulated to release deposited energy of the latent image in the form of bluish photostimulated visible light. *Step 3:* the bluish photostimulated light (PSL) is then collected by an optical system containing a chromatic filter (that prevents the red stimulus light from being collected) and channeled to a photo-multiplier tube (PMT). *Step 4:* PSL light is converted by the PMT to analogue electrical signals in proportion to quantity of PSL collected. *Step 5:* analog electrical signals are amplified, filtered, passed through an analog-to-digital (A/D) converter and “clock” synchronized to a spatially correct pixel location within a binary data matrix (Fig. 4 illustrates assignment of binary data to a pixel matrix).

The actual size of the binary pixel element (length and width) is determined by the scanning speed of the transport mechanism in one direction and the clock speed of the sampling along each scan line (how fast the laser spot moves divided by the sampling rate). Although resolution is limited by pixel size, the size of individual phosphor crystals, the phosphor layer thickness of the image plate, laser spot size and optics also contribute to the overall quality (resolution) of the image. Each of these components thus becomes a very essential contributor to the overall binary matrix that represents the digital image. These individual elements represent the smallest unit of storage of a binary digital image that can be discretely controlled by the CR data acquisition and

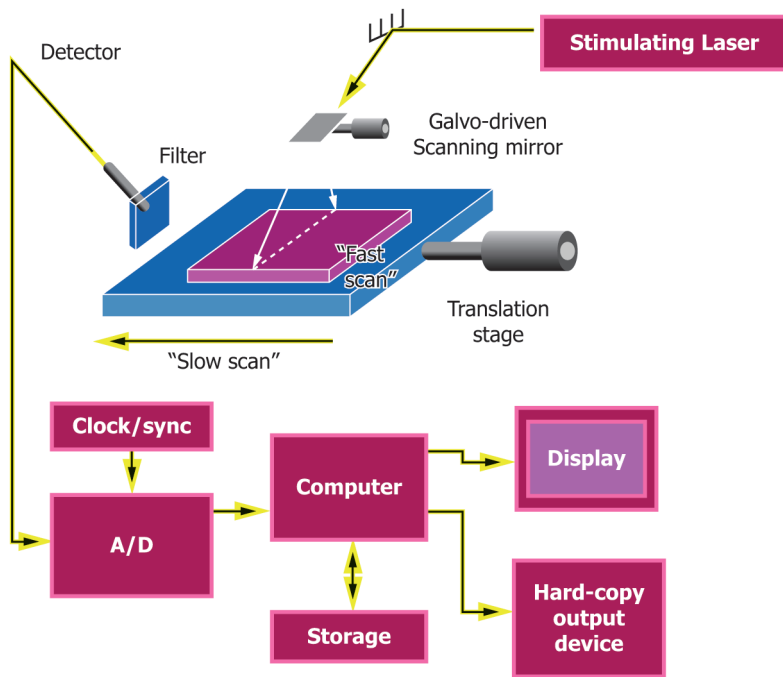

Illustration courtesy of Carestream Health

FIG. 3 Fundamental CR Image Acquisition and Display Process

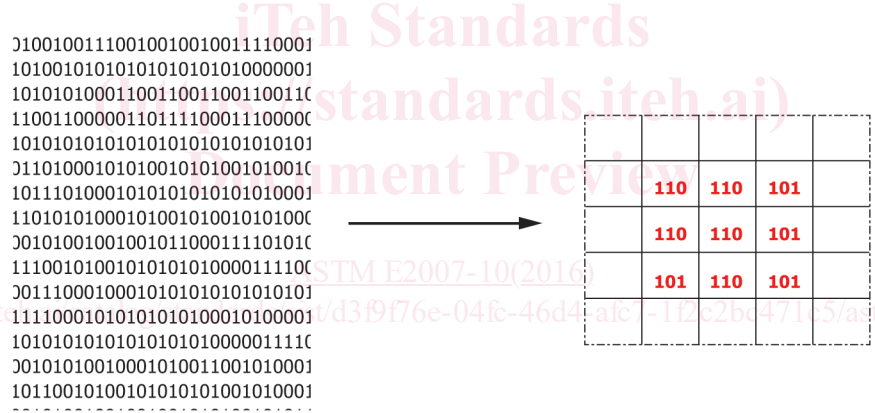
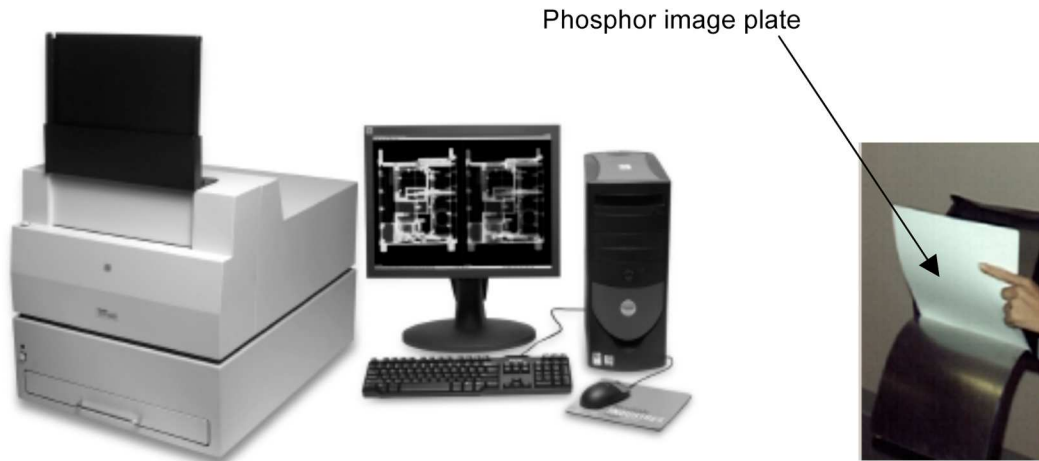

FIG. 4 Assignment of Binary Data to a Pixel Matrix (3-bit depth illustrated)

display system components and are commonly called “pixels.” The term “pixel” is thus derived from two word components of the digital matrix, that is, picture (or pix) and elements (els) or “pixels.” Picture elements or pixels become the basis for all technical imaging attributes that comprise quality and composition of the resultant image. An organized matrix of picture elements (pixels) containing binary data is called a binary pixel data matrix since proportional gray levels have not yet been assigned. (see 11.1.2) contains basic tutorial information on binary numbering system and its usefulness for digital applications).

Step 6: Computer algorithms (a string of mathematical instructions) are applied that match binary pixel data with arbitrary files (called look-up-tables) to assign individual pixel gray scale levels. Example: for 4096 possible shades or levels of gray for a 12-bit image, gray scale levels are thus derived when a computer assigns equal divisions between white (“0”) and black (“4095”) with each incremental division a derivative (shade) of black or white (that is, gray) for a negative view image. An example is to assign gray scale levels in linear proportion to the magnitude of the binary numbers (that is, a higher binary number associated with a greater amount of photo stimulated light for that pixel registration can be assigned a corresponding darker gray value) to create an original gray scale data matrix with a standard format (DICONDE, TIFF, BITMAP, etc.) ready for software transformation. Fig. 5-A illustrates a simple linear look-up-table for an original gray scale data matrix where binary numbers are also represented by their corresponding numerical integers (called pixel value integers). In this example for a 12-bit image, there are 4096 gray scale divisions that precisely correspond with 4096 numerical pixel value integers. Fig. 5-B illustrates a graphical version of the application as might be applied by an algorithm to produce an image with a gray tonal appearance (visually similar to a



Illustrations courtesy of Carestream Health & Fujifilm NDT Systems

FIG. 6 Typical CR Scanner, Workstation, and Image Plate

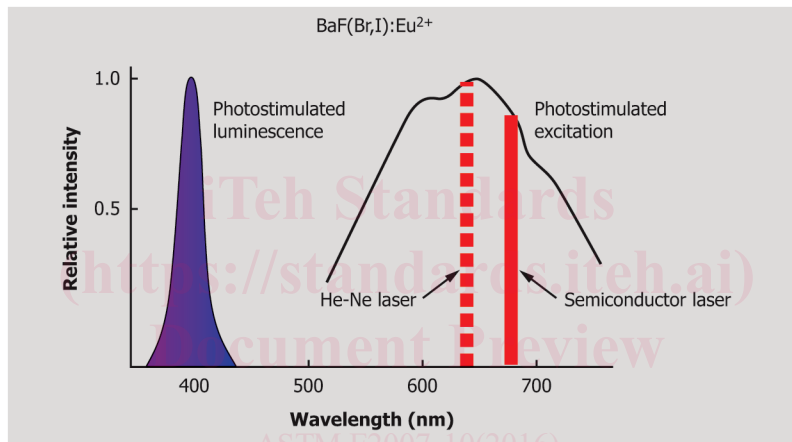

Illustration courtesy of Fujifilm NDT Systems

FIG. 7 Spectra of Photostimulated Luminescence and Excitation

6.3 *Recent History of Computed Radiography:* With the introduction of photostimulable luminescence imaging systems in the early 1980's in combination with continued advancements in computer technologies, CR was "born." In the early 1990's, further advancements in computer technologies in conjunction with refined phosphor imaging plate developments initiated limited applications, mostly driven by the medical industry. The medical industry became interested in CR for two reasons: 1) The desire for electronic transport of digital images for remote diagnostics and 2) The increased latitude of diagnostic capability with a single patient exposure. Throughout the 90's, technology advancements in CR were driven primarily by the medical industry for similar reasons. In the late 90's, as image quality attributes continued to improve, industrial radiographers became more interested in CR for its ability to detect small features within heavier materials with reliabilities approaching some classes of film systems. In 1999, continued industrial user interests led to the development and publication of ASTM's first computed radiography standard, Practice E2033. ASME adopted its first article for ASME Code compliant computed radiography in 2004. In 2005, further interests from industrial users led to the development and publishing of Practices E2445 and E2446. ASTM published its first ever set of all-digital reference images (E2422) for the inspection of aluminum castings in 2005.

6.4 *PSL Crystal Structure:* Fig. 8 illustrates the basic physical structure of a typical Barium Fluorohalide phosphor crystal. illustrates a photo-micrograph of these type crystal grains as seen through a scanning electron microscope at approximately 5 microns. These crystal structures are the basis of the phosphor layer shown in Fig. 2 and constitute the heart of the physical "PSL" process described in the following text.

6.5 *Latent Image Formation:* A widely-accepted mechanism for PSL in europium-activated halides was proposed by Takahashi et al (see 11.1.10). In the phosphor-making process, halogen ion vacancies, or "F^{••}" centers, are created. Upon exposure of the phosphor particles to ionizing radiation (Fig. 10 provides an energy level diagram that illustrates this process), electrons are excited to a higher energy level (conduction band) and leave behind a hole at the Eu²⁺ ion (valance band). While some of these electrons immediately recombine and excite the Eu²⁺ to promptly emit, others are trapped at the F^{••} centers to form metastable F centers,

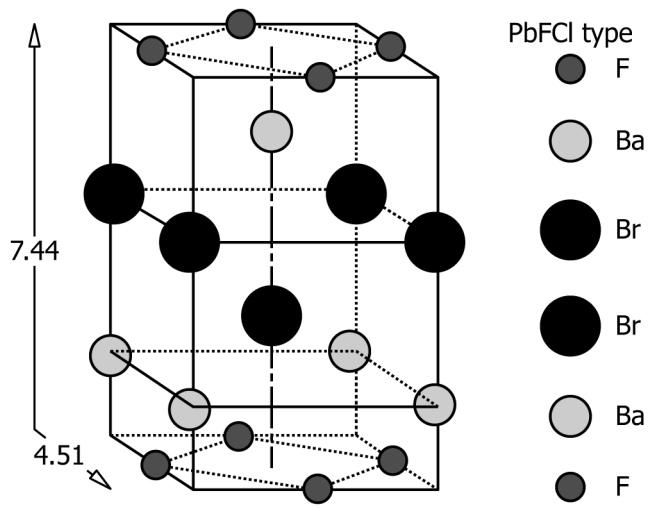
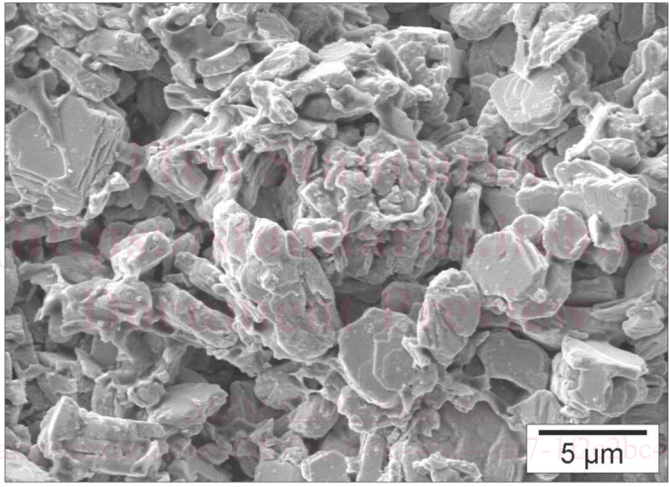

Illustration courtesy of Fujifilm NDT Systems

FIG. 8 BaFBr Crystal Structure



<https://standards.iteh.ai/catalog/standards/sist/71c5/astm-e2007-102016>

Illustration courtesy of Carestream Health

FIG. 9 Conventional BaFX: Eu Grains (5 microns)

also known as color centers, from the German word “Farbe,” which means color. The energy stored in these electron-hole pairs is the basis of the CR latent image and remains quite stable for hours. This mechanism has been disputed by some and supported by others; however, the end result is photostimulable luminescence.

6.6 *Processing the Latent Image:* When this phosphor (bearing the latent image) is subsequently exposed (that is, scanned with a laser as shown in Fig. 3) to a source of red light, most of the trapped electrons are “liberated” and return to the lower energy level (valence band) of the phosphor molecule causing PSL to be emitted. Fig. 11 provides a simplified graphic illustration of this process that may be helpful in better understanding the fundamentals of this unique process.

6.7 *Residual Latent Image Removal:* Following a normal latent image process scan (see Fig. 3), all phosphors on the imaging plate must be further exposed to a high intensity source of white light in order to remove any remaining “residual” trapped electrons in the F centers. This process is referred to as an IP “erasure” and is usually performed subsequent to the IP scan and prior to any subsequent re-exposures of the IP. If an erasure cycle is not performed, an unwanted residual latent image may be superimposed on the next CR exposure if the IP is re-exposed soon after the first exposure. In the event no subsequent re-exposure of the IP is performed, any residual latent image (trapped electrons) will eventually fade as natural sources of red light energy (heat, etc.) cause remaining electrons to be liberated via the same physical process described above. Similarly, if erased IP’s are stored near sources of radiation (background or other sources of ionizing radiation) an unwanted residual latent image (background) may develop within affected phosphors of the IP. Fig. 12 illustrates a typical life cycle for the eventual generation of PSL with bluish X-ray luminescence *during* radiation exposure, bluish after-glow luminescence *subsequent* to radiation exposure, a bluish