



Designation: **C1581/C1581M—09a C1581/C1581M – 16**

# Standard Test Method for Determining Age at Cracking and Induced Tensile Stress Characteristics of Mortar and Concrete under Restrained Shrinkage<sup>1</sup>

This standard is issued under the fixed designation C1581/C1581M; the number immediately following the designation indicates the year of original adoption or, in the case of revision, the year of last revision. A number in parentheses indicates the year of last reapproval. A superscript epsilon ( $\epsilon$ ) indicates an editorial change since the last revision or reapproval.

## 1. Scope\*

1.1 This test method covers the laboratory determination of the age at cracking and induced tensile stress characteristics of mortar or concrete specimens under restrained shrinkage. The procedure can be used to determine the effects of variations in the proportions and material properties of mortar or concrete on cracking due to both drying shrinkage and deformations caused by autogenous shrinkage and heat of hydration.

1.2 This test method is not intended for expansive materials.

1.3 The values stated in either SI units or inch-pound units are to be regarded separately as standard. The values stated in each system may not be exact equivalents; therefore, each system shall be used independently of the other. Combining values from the two systems may result in non-conformance with the standard.

1.4 *This standard does not purport to address all of the safety concerns, if any, associated with its use. It is the responsibility of the user of this standard to establish appropriate safety and health practices and to determine the applicability of regulatory limitations prior to use. (Warning—Fresh hydraulic cementitious mixtures are caustic and may cause chemical burns to skin and tissue upon prolonged exposure.<sup>2</sup>)*

## 2. Referenced Documents

2.1 *ASTM Standards:*<sup>3</sup>

~~C33~~[C33/C33M](#) Specification for Concrete Aggregates

[C125](#) Terminology Relating to Concrete and Concrete Aggregates

[C138/C138M](#) Test Method for Density (Unit Weight), Yield, and Air Content (Gravimetric) of Concrete

[C143/C143M](#) Test Method for Slump of Hydraulic-Cement Concrete

~~C150~~[C150/C150M](#) Specification for Portland Cement

[C171](#) Specification for Sheet Materials for Curing Concrete

[C192/C192M](#) Practice for Making and Curing Concrete Test Specimens in the Laboratory

~~C387~~[C387/C387M](#) Specification for Packaged, Dry, Combined Materials for ~~Mortar and Concrete~~ [Concrete and High Strength Mortar](#)

~~C595~~[C595/C595M](#) Specification for Blended Hydraulic Cements

~~C1157~~[C1157/C1157M](#) Performance Specification for Hydraulic Cement

[C1437](#) Test Method for Flow of Hydraulic Cement Mortar

[F441/F441M](#) Specification for Chlorinated Poly(Vinyl Chloride) (CPVC) Plastic Pipe, Schedules 40 and 80

2.2 *ASME Standards:*<sup>4</sup>

[B 46.1](#) Surface Texture (Surface Roughness, Waviness and Lay)

<sup>1</sup> This test method is under the jurisdiction of ASTM Committee C09 on Concrete and Concrete Aggregates and is the direct responsibility of Subcommittee C09.68 on Volume Change.

Current edition approved July 1, 2009/July 1, 2016. Published August 2009/August 2016. Originally approved in 2004. Last previous edition approved in 2009 as ~~C1581—09~~[C1581 – 09a](#). DOI: ~~10.1520/C1581\_C1581M-09A~~[10.1520/C1581\\_C1581M-16](#).

<sup>2</sup> Section on Safety Precautions, *Manual of Aggregate and Concrete Testing*, *Annual Book of ASTM Standards*, Vol 04.02.

<sup>3</sup> For referenced ASTM standards, visit the ASTM website, [www.astm.org](http://www.astm.org), or contact ASTM Customer Service at [service@astm.org](mailto:service@astm.org). For *Annual Book of ASTM Standards* volume information, refer to the standard's Document Summary page on the ASTM website.

<sup>4</sup> Available from American Society of Mechanical Engineers (ASME), ASME International Headquarters, Three Park Ave., New York, NY 10016-5990, <http://www.asme.org>.

\*A Summary of Changes section appears at the end of this standard

### 3. Terminology

#### 3.1 Definitions:

3.1.1 For definitions of terms used in this test method, refer to Terminology C125.

#### 3.2 Definitions of Terms Specific to This Standard:

3.2.1 *age at cracking, n*—the age of each test specimen, measured from the time of casting, when a sudden decrease in strain occurs.

3.2.2 *net strain, n*—the value corresponding to the difference between the strain in the steel ring at each recorded time and the initial strain.

### 4. Summary of Test Method

4.1 A sample of freshly mixed mortar or concrete is compacted in a circular mold around an instrumented steel ring. The compressive strain developed in the steel ring caused by shrinkage of the mortar or concrete specimen is measured from the time of casting (1-6).<sup>5</sup> Cracking of the test specimen is indicated by a sudden decrease in the steel ring strain. The age at cracking and the rate of tensile stress development in the test specimen are indicators of the material's resistance to cracking under restrained shrinkage.

### 5. Significance and Use

5.1 This test method is for relative comparison of materials and is not intended to determine the age at cracking of mortar or concrete in any specific type of structure, configuration, or exposure.

5.2 This test method is applicable to mixtures with aggregates of 13-mm [0.5-in.] maximum nominal size or less.

5.3 This test method is useful for determining the relative likelihood of early-age cracking of different cementitious mixtures and for aiding in the selection of cement-based materials that are less likely to crack under restrained shrinkage. Actual cracking tendency in service depends on many variables including type of structure, degree of restraint, rate of property development, construction and curing methods, and environmental conditions.

5.4 This test method can be used to determine the relative effects of material variations on induced tensile stresses and cracking potential. These variations can include, but are not limited to, aggregate source, aggregate gradation, cement type, cement content, water content, supplementary cementing materials, or chemical admixtures.

5.5 For materials that have not cracked during the test, the rate of tensile stress development at the time the test is terminated provides a basis for comparison of the materials.

### 6. Apparatus

6.1 *Steel ring*—Structural steel pipe with a wall thickness of  $13 \pm 1$  mm [ $0.50 \pm 0.05$  in.], an outside diameter of  $330 \pm 3$  mm [ $13.0 \pm 0.12$  in.] and a height of  $150 \pm 6$  mm [ $6.0 \pm 0.25$  in.] (see Fig. 1). Machine the inner and outer faces to produce smooth surfaces with a texture of 1.6 micrometres [63 microinches] or finer, as defined in ASME B 46.1.

6.2 *Strain gages*—As a minimum, use two electrical resistance strain gages to monitor the strain development in the steel ring. Each strain gage shall be wired in a quarter-bridge configuration (that is, one leg of a full Wheatstone bridge). See Note 1 for additional information.

6.3 *Data acquisition system*—The data acquisition system shall be compatible with the strain instrumentation and automatically record each strain gage independently. The resolution of the system shall be  $\pm 0.0000005$  m/m [in./in.]. The system shall be capable of recording strain data at intervals not to exceed 30 minutes.

NOTE 1—Use of a precision resistor, to balance the leg of the bridge, a strain conditioner input module, to complete the other half of the bridge, and a 16-channel interface board has been found to adequately provide the required resolution of the system.

6.4 *Base*—Epoxy-coated plywood or other non-absorptive and non-reactive surface.

6.5 *Outer ring*—Use one of the following alternative materials as the outer ring.

6.5.1 *PVC pipe*—Schedule 80-18 PVC pipe, in accordance with Specification F441/F441M, with a  $405 \pm 3$ -mm [ $16.0 \pm 0.12$ -in.] inside diameter and  $150 \pm 6$ -mm [ $6.0 \pm 0.25$ -in.] height (see Fig. 1).

6.5.2 *Steel outer ring*—3-mm [0.125-in.] thick steel sheeting formed to obtain a  $405 \pm 3$ -mm [ $16.0 \pm 0.12$ -in.] inside diameter and  $150 \pm 6$ -mm [ $6.0 \pm 0.25$ -in.] height.

6.5.3 *Other materials*—Other suitable non-absorptive and non-reactive materials formed to obtain a  $405 \pm 3$ -mm [ $16.0 \pm 0.12$ -in.] inside diameter and  $150 \pm 6$ -mm [ $6.0 \pm 0.25$ -in.] height.

6.6 *Testing environment*—Store the specimens in an environmentally controlled room with constant air temperature of  $23.0 \pm 2.0$  °C [ $73.5 \pm 3.5$  °F] and relative humidity of  $50 \pm 4$  %.

<sup>5</sup> The boldface numbers in parenthesis refer to the list of references at the end of this test method.

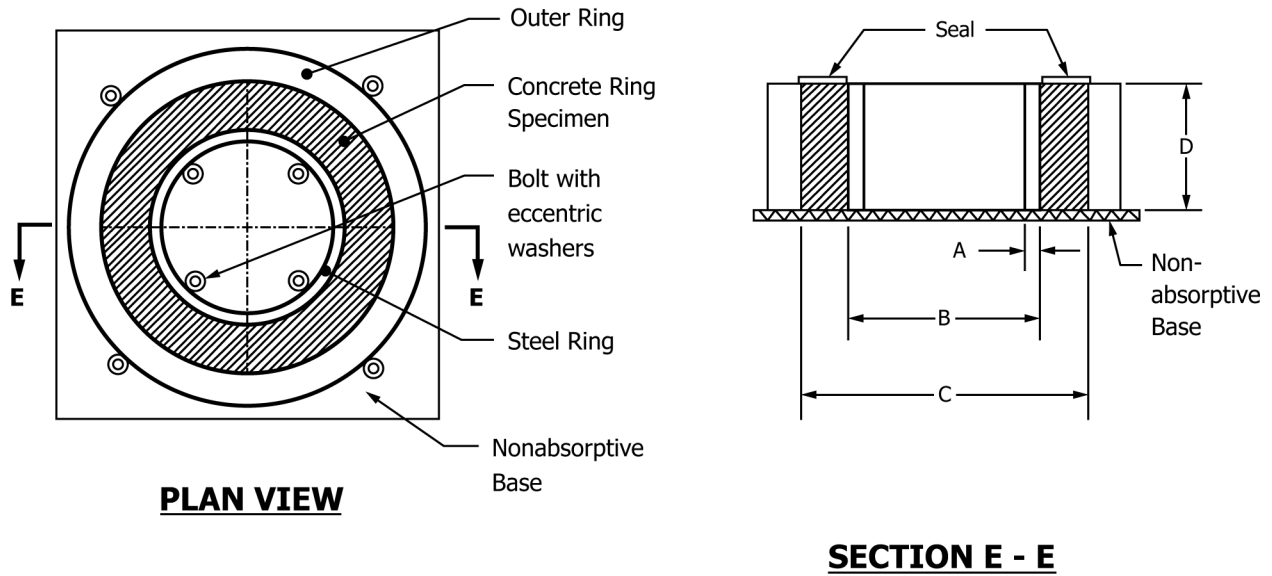

| Figure Dimensions | SI Units   | Inch-Pound Units |
|-------------------|------------|------------------|
| A                 | 13 ± 1 mm  | 0.50 ± 0.05 in.  |
| B                 | 330 ± 3 mm | 13.0 ± 0.12 in.  |
| C                 | 405 ± 3 mm | 16.0 ± 0.12 in.  |
| D                 | 150 ± 6 mm | 6.0 ± 0.25 in.   |

**Notes:**

1. Not to scale.
2. Bolts with eccentric washers for securing steel ring and outer ring to the base during casting of the test specimen (8 required).

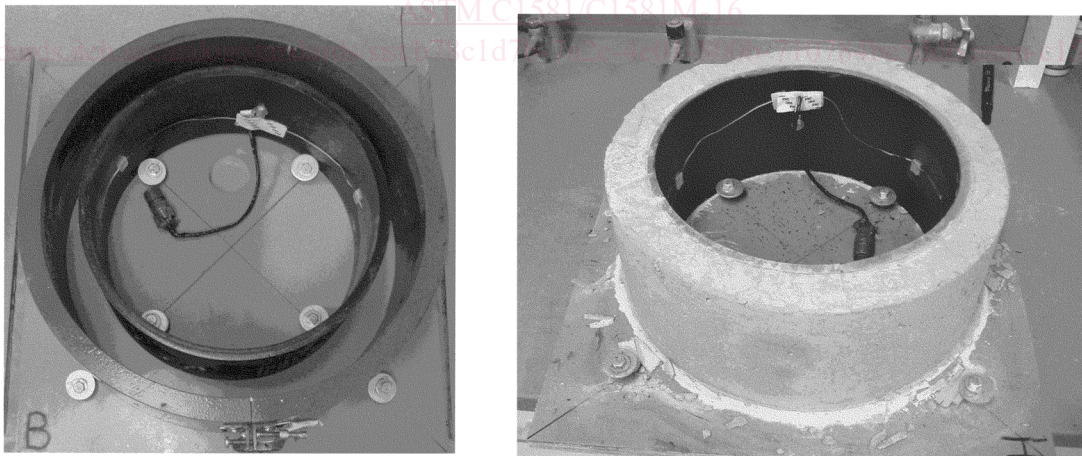

FIG. 1 Test specimen dimensions (top), specimen mold (bottom left), and specimen (bottom right).

**7. Materials and Mixing**

7.1 *Materials:*

7.1.1 *Cement*—Cement shall conform to Specifications [C150C150/C150M](#), [C595C595/C595M](#), or [C1157C1157/C1157M](#).

7.1.2 *Aggregates*—Aggregates shall conform to Specification [C33C33/C33M](#). The maximum nominal size of the coarse aggregate shall be 13 mm [0.5 in.] or less.

## 7.2 Mixing:

7.2.1 *Concrete mixtures*—Machine mix the concrete as prescribed in Practice [C192/C192M](#).

7.2.2 *Mortar mixtures*—Mix the mortar as prescribed in Specification [C387C387/C387M](#).

## 8. Properties of Fresh Mixtures

8.1 *Concrete mixtures*—Samples of freshly mixed concrete shall be tested in accordance with the following methods:

8.1.1 *Density (unit weight) and air content*—Test Method [C138/C138M](#).

8.1.2 *Slump*—Test Method [C143/C143M](#).

8.2 *Mortar mixtures*—Samples of freshly mixed mortar shall be tested in accordance with the following methods:

8.2.1 *Density*—Specification [C387C387/C387M](#).

8.2.2 *Flow*—Test Method [C1437](#).

## 9. Specimen Fabrication and Test Setup

9.1 Bond two strain gages at midheight locations on the interior surface of the steel ring along a diameter; that is, mount the second gage diametrically opposite the first gage. Orient the gages to measure strain in the circumferential direction. Follow the manufacturer's procedures for mounting and waterproofing the gages on the steel ring and connecting lead-wires to the strain gage tabs.

9.2 *Test specimen mold*—The test specimen mold consists of a base, an inner steel ring and an outer ring.

9.2.1 Fabricate a base for each test specimen as described in Section [5.46.4](#). The top surface of each base shall minimize frictional restraint of the specimen.

NOTE 2—Use of an epoxy coating or a Mylar sheet covering has been found to provide a suitable surface between the test specimen and the base.

9.2.2 Secure the steel ring to the base before casting using bolts with eccentric washers (see [Fig. 1](#)).

9.2.2.1 Coat the outer surface of the steel ring with a release agent.

9.2.3 Coat the inner surface of the outer ring with a release agent.

9.2.4 Secure the outer ring to the base to complete the test specimen mold using bolts with eccentric washers. Maintain a  $38 \pm 1.5$ -mm [ $1.50 \pm 0.06$ -in.] space between the inner steel ring and the outer ring (see [Fig. 1](#)).

9.3 Make and cure at least three test specimens for each material and test condition following the applicable requirements of Practice [C192/C192M](#). In making a specimen, place the test specimen mold on a vibrating table, fill the mold in two approximately equal layers, rod each layer 75 times using a 10-mm [ $3/8$ -in.] diameter rod, and vibrate each layer to consolidate the mixture.

9.4 Strike-off the test specimen surface after consolidation. Finish with the minimum manipulation necessary to achieve a flat surface. Remove any fresh concrete or mortar that has spilled inside the steel ring or outside the outer ring so that the base is clean. Transfer the test specimens to the testing environment within 10 minutes after completion of casting.

9.5 Upon transfer of the test specimens to the testing environment, immediately loosen the bolts with eccentric washers and rotate the washers so they are not in contact with the steel ring and outer ring. Within 2 minutes after loosening the bolts with eccentric washers, connect the strain gage lead-wires to the data acquisition system, record the time, and begin monitoring the strain gages at intervals not greater than 30 minutes. Ensure that the strain gage connecting wires are clean of loose material before making the connections. The time of the first strain measurement is taken as zero age of the specimen.

NOTE 3—Monitoring the strain gages soon after casting provides information on the internal deformations caused by autogenous shrinkage and heat of hydration ([4](#)).

9.6 *Curing*—Unless otherwise specified, test specimens shall be moist cured in the molds for 24 h at  $23.0 \pm 2.0$  °C [ $73.5 \pm 3.5$  °F] using wet burlap covered with polyethylene film meeting the requirements of Specification [C171](#). Begin the curing process within 5 minutes after the first strain reading. If the curing period is longer than 24 h, remove the outer ring at 24 h and continue the curing process.

9.7 At the end of curing and between strain measurements, prepare the test specimens for drying as follows. Complete the test specimen preparation within 15 minutes.

9.7.1 Remove the outer ring, if it is still in place, and/or remove the polyethylene film and burlap.

9.7.2 Gently remove loose material, if present, from the top surface of the test specimen.

9.7.3 Seal the top surface of the test specimen using one of the following alternative procedures.

NOTE 4—With the top surface sealed, and the specimen resting on its base, the test specimen dries from the outer circumferential surface only.

9.7.3.1 *Paraffin wax*—Coat the top surface of the test specimen with molten paraffin wax. Take precautions to ensure that the outer circumference of the test specimen is not coated with the paraffin wax.

NOTE 5—Use of a 40-mm [1.5-in.] wide brush has been found to be an appropriate means of applying the paraffin wax to the top surface of the test specimens.

9.7.3.2 *Adhesive aluminum-foil tape*—Seal the top surface of the test specimen with adhesive aluminum-foil tape.